

OPHTHALMOLOGIE



Mehrweginstrumente  
**salensa** ReUse Line

100% Made in Germany • Reparatur Service • MDR konform



Produktkatalog 2026

---



## **salensa ReUse Line – Mehrweginstrumente**

**100 % Made in Germany - Präzision, Qualität und Verlässlichkeit.**

Die salensa ReUse Line steht für hochwertige Mehrweginstrumente, die seit Generationen von einem familiengeführten Unternehmen in Deutschland entwickelt und gefertigt werden – unter Einsatz modernster Produktionstechnologien. Jedes Instrument erfüllt höchste Anforderungen an Präzision, Funktionalität und Langlebigkeit und ist für den zuverlässigen Einsatz in der operativen Augenchirurgie konzipiert.

Alle Produkte erfüllen die geltenden regulatorischen Anforderungen, insbesondere der EU-Medizinprodukteverordnung (MDR), und entsprechen aktuellen Qualitäts- und Sicherheitsstandards. Mit einem Portfolio von über 1.200 Instrumenten bietet unser langjährig erfahrener Hersteller ein umfassendes Spektrum – von bewährten Standardinstrumenten bis hin zu spezialisierten Lösungen für mikrochirurgische Anwendungen. Hochwertige Materialien und ergonomisch optimierte Designs unterstützen präzises, sicheres und effizientes Arbeiten im klinischen Alltag.

Die salensa ReUse Line ermöglicht eine wirtschaftliche und nachhaltige Instrumentennutzung. Ergänzend trägt ein schneller und qualifizierter Reparaturservice direkt beim Hersteller zur Sicherstellung der Einsatzbereitschaft sowie zur Verlängerung der Produktlebenszyklen bei.

**salensa – Ihr autorisierter Distributor für kompetente und individuelle Beratung.  
Kontaktieren Sie uns!**

---

**KATALOGÜBERSICHT**  
**QUICK REFERENCE**

**SOMMAIRE DU CATALOGUE**  
**SUMARIO DEL CATÁLOGO**

Sperrelevatoren, Wundsperrerr	Eye Specula, Retractors	Blepharostats, Ecarteurs	Blefaróstatos, Separadores	<b>1 - 16</b>
Lidhalter	Lid Retractors	Releveurs à Paupières	Retradores para Párpados	<b>17 - 18</b>
Häkchen, IOL-Instrumente	Hooks, IOL-Instruments	Crochets, Instrument p. IOL	Ganchos, Instrument p. IOL	<b>19 - 35</b>
Starmesser und -nadeln, Lanzen, Skalpelle, Satomesser	Cataract Knives, Keratomes, Scalpels, Sato Knives	Couteaux lancéolaires et cata- ract, Bistouries, Couteaux Sato	Cuchillos lanceolares y catara- tas, Bisturries, Cuchillos Sato	<b>36 - 39</b>
Messer, Diszissionsnadeln, Schaber, Meissel, Spateln, Chopper	Knives, Discission Needles, Corneal Scarifiers, Chisel, Spatulas, Chopper	Couteaux, Rugines, Ciseau, Kystotomes, Spatules, Chopper	Cuchillos, Legras, Cincel, Quistotomos Espátulas, Chopper	<b>40 - 49</b>
Fremdkörper- und Doppel- instrumente	Foreign body and double ended instruments	Corps étrangers et instruments doubles	Cuerpos extranos y instrumentes dobles	<b>50 - 52</b>
Löffel, Schlingen, Sonden	Spoons, Loops, Probes	Curettes, Anses, Stylets	Cucharillas, Asas, Estiletes	<b>53 - 58</b>
Klemmen, Stanzen, Dilatatoren	Clamps, Punches, Dilators	Pinces-Clamps, Emporte-Pièces, Dilatateurs	Pinzas-Clamps, Punzones, Dilatadores	<b>59 - 63</b>
Trephinen, Markierinstrumente	Trephines, Marking Instruments	Trépan, Marqueurs	Trépanos, Marcadores	<b>64 - 67</b>
Irispinzetten, Pinzetten für Mikro-Chirurgie, IOL-Pinzetten	Iris Forceps, Forceps for Micro-Surgery, IOL-Forceps	Pinces à Iris; Pinces à Micro- Chirurgie, Pinces pour IOL	Pinzas para Iris, Pinzas para Micro-Cirurgia, Pinzas para IOL	<b>68 - 74</b>
Kapsulorhexis-Pinzetten	Capsulorhexis Forceps	Pinces à capsulorhexis	Pinzas capsulorhexis	<b>75 - 77</b>
IOL-Pinzetten	IOL-Forceps	Pinces pour IOL	Pinzas para IOL	<b>78 - 81</b>
Kapselpinzetten	Capsule Forceps	Pinces Capsulaires	Pinzas capsulares	<b>82</b>
Bindehautpinzetten	Conjunctival Forceps	Pinces à Conjunctiva	Pinza para Conjunctiva	<b>82</b>
Fixierpinzetten	Fixation Forceps	Pinces à Fixer	Pinzas de Fijación	<b>83 - 84</b>
Pinzetten für Schieloperation	Strabismus Forceps	Pinces à Strabisme	Pinzas para Estrabismo	<b>85</b>
Muskelpinzetten	Muscle Forceps	Pinces Musculaires	Pinzas Musculares	<b>86 - 87</b>
Entropionspinzetten	Entropium Forceps	Pinces à entropion	Pinzas de Entropión	<b>88 - 89</b>
Chalazionspinzetten	Chalazion Forceps	Pinces à Chalazion	Pinzas de Chalazion	<b>90</b>
Cilienpinzetten	Cilia Forceps	Pinces à Épiler les Cils	Pinzas Depilatorias	<b>91</b>
Pinzetten	Forceps	Pinces	Pinzas	<b>92</b>
Nahtpinzetten	Suture Forceps	Pinces à Sutures	Pinzas para Suturas	<b>93 - 98</b>
Nadelhalter	Needle Holders	Porte-Aiguilles	Porta-Agujas	<b>100 - 111</b>
Klingenhalter, Skalpellgriffe	Razor Blade Holders, Scalpel Handles	Porte-Lames, Manche de Scalpel	Porta-Hojas, Mangos de Bisturi	<b>113 - 114</b>
Kanülen	Cannulas	Canules	Canulas	<b>115 - 122</b>
Silikon-Teile, Sterilisierbehälter	Silicone-articles, Trays	Articles de silicone, Boîtes	Articulos de silicona, Cajas para esterilización	<b>123 - 127</b>
Iridektomiescheren, Federscheren, Weckerscheren	Iris Scissors, Springhandle and Wecker Scissors	Ciseaux à Iridectomie, «Wecker» etc.	Tijeras para Iridectomia, „Wecker“ etc.	<b>128 - 130</b>
Vannas Scheren	Vannas Scissors	Ciseaux Vannas	Tijeras Vannas	<b>131 - 134</b>
Kapselscheren	Capsule Scissors	Ciseaux Capsulaires	Tijeras para Capsula	<b>135</b>

Mikro-Federschere	Micro-Springhandle Scissors	Ciseaux à Micro-Chirurgie	Tijeras para Micro-Cirugía	<b>136 - 139</b>
Hornhautscheren, rechts und links	Corneal Scissors, left and right	Ciseaux pour la Cornée, gauche et à droite	Tijeras para la Cornea, derecha y izquierda	<b>140 - 143</b>
Hornhautscheren	Corneal scissors	Ciseaux pour la Cornée	Tijeras para la Cornea	<b>144 - 145</b>
Federschere divers	Spring Handle Scissors miscellaneous	Ciseaux divers	Tijeras diversas	<b>146</b>
Sehnenschere	Tenotomy Scissors	Ciseaux à Ténatomie	Tijeras para Tenotomia	<b>147 - 149</b>
Strabismus- und Sehnenschere	Strabismus and Tenotomy Scissors	Ciseaux à Strabisme et Ténatomie	Tijeras para Estrabismo y Tenotomia	<b>150 - 151</b>
Augenschere	Iris Scissors	Ciseaux Oculaires	Tijeras Oculares	<b>152 - 156</b>
Fadenschere	Stitch Scissors	Ciseaux par Incision	Tijeras para incisión	<b>157</b>
Enukleationsscheren	Enucleation Scissors	Ciseaux à Énucléer	Tijeras para Enucleación	<b>158</b>
Glaskörperinstrumente	Vitreous body instruments	Instruments à Vitrectomie	Instruments para cuerpo vitréo	<b>159</b>
Verbandscheren	Bandage scissors	Ciseaux à pansements	Tijeras para vendajes	<b>168</b>
Alle Augeninstrumente und -scheren sind, falls nicht anders vermerkt, in natürlicher Größe abgebildet.	All ophthalmic instruments and eye scissors are shown in natural size, unless otherwise stated. Iris Scissors	Tous les instruments et ciseaux ophtalmologiques sont, sauf indication contraire, représentés en grandeur naturelle.	Todos los instrumentos y tijeras para oftalmología son representados en tamaño natural, salvo que esté indicada otra cosa.	
Ausführliches Inhaltsverzeichnis am Ende des Katalogs.	Detailed index at the end of the catalogue.	Table des matières détaillée à la fin du catalogue.	Un índice detallado se encuentra en el fin del catálogo.	
Alle aufgeführten Medizinpro- dukte sind mit dem CE-Zeichen versehen. Bei Produkten höher Klasse I wird die Kennnummer der benannten Stelle zusätz- liche versehen.	All listed medical devices bear the CE marking. For products above Class I, the identification number of the notified body is additionally applied.	Tous les dispositifs médicaux répertoriés sont pourvus du marquage CE. Pour les produits de classe supérieure à la classe I, le numéro d'identification de l'organisme notifié est apposé en complément.	Todos los productos sanitarios enumerados cuentan con el marcado CE. En los productos de clase superior a I, se añade adicionalmente el número de identificación del organismo notificado.	

**SA60-1402-10**

LIEBERMANN

10 mm

V-Valven, temporal, ohne Spülung, für Kinder  
V-Wire, temporal, without irrigation, for children  
V-oreilles, temporal, sans irrigation, pour enfants  
V-hojas, temporal, sin irrigación, para niños

**SA60-1402-15**

LIEBERMANN

15 mm

V-Valven, temporal, ohne Spülung, für Erwachsene  
V-Wire, temporal, without irrigation, for adults  
V-oreilles, temporal, sans irrigation, pour adultes  
V-hojas, temporal, sin irrigación, para adultos

**SA60-1402N15**

LIEBERMANN

15 mm

V-Valven, nasal, ohne Spülung, für Erwachsene  
V-Wire, nasal, without irrigation, for adults  
V-oreilles, nasal, sans irrigation, pour adultes  
V-hojas, nasal, sin irrigación, para adultos

**SA60-1412-15**

LIEBERMANN

15 mm

V-Valven, temporal, mit Spülung, für Erwachsene  
V-Wire, temporal, with irrigation, for adults  
V-oreilles, temporal, avec irrigation, pour adultes  
V-hojas, temporal, con irrigación, para adultos

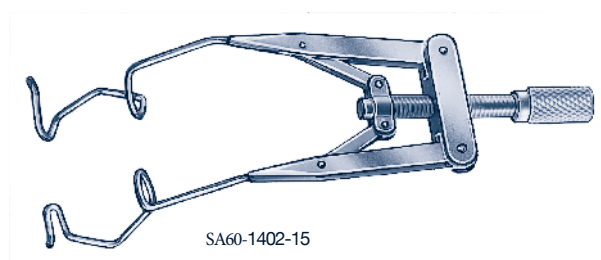

**SA60-1403-05**

LIEBERMANN

5 mm

K-Valven, temporal, ohne Spülung, für Säuglinge  
 K-Wire, temporal, without irrigation, for infants  
 K-oreilles, temporal, sans irrigation, pour nourrissons  
 K-hojas, temporal, sin irrigación, para lactantes

**SA60-1403-09**

LIEBERMANN

9 mm

K-Valven, temporal, ohne Spülung, für Kinder  
 K-Wire, temporal, without irrigation, for children  
 K-oreilles, temporal, sans irrigation, pour enfants  
 K-hojas, temporal, sin irrigación, para niños

**SA60-1403-15**

LIEBERMANN

15 mm

K-Valven, temporal, ohne Spülung, für Erwachsene  
 K-Wire, temporal, without irrigation, for adults  
 K-oreilles, temporal, sans irrigation, pour adultes  
 K-hojas, temporal, sin irrigación, para adultos

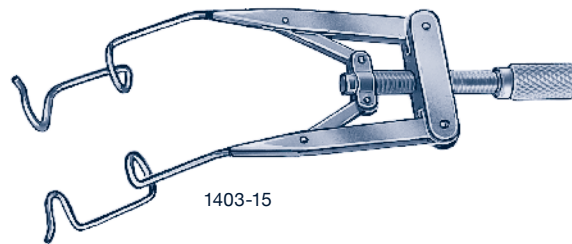
**SA60-1403N15**

LIEBERMANN

15 mm

K-Valven, nasal, ohne Spülung, für Erwachsene  
 K-Wire, nasal, without irrigation, for adults  
 K-oreilles, nasal, sans irrigation, pour adultes  
 K-hojas, nasal, sin irrigación, para adultos

**SA60-1413-15**

LIEBERMANN

15 mm

K-Valven, temporal, mit Spülung, für Erwachsene  
 K-Wire, temporal, with irrigation, for adults  
 K-oreilles, temporal, avec irrigation, pour adultes  
 K-hojas, temporal, con irrigación, para adultos

**SA60-1404-10**  
LIEBERMANN

10 mm

volle Valven, für Kinder  
solid blades, for children  
mors solides, pour enfants  
hojas solidas, para niños

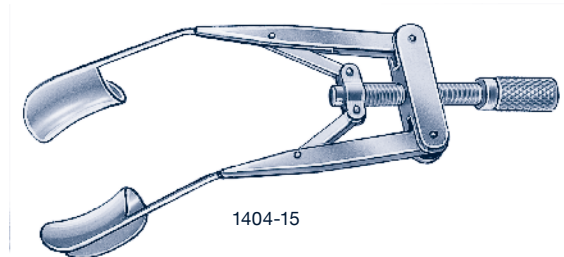
**SA60-1404-15**  
LIEBERMANN

15 mm

volle Valven, für Erwachsene  
solid blades, for adults  
mors solides, pour adultes  
hojas solidas, para adultos

**SA60-1405-15**  
LIEBERMANN

15 mm

volle umkehrbare Valven, für Erwachsene  
solid reversible valves, for adults  
mors solides réversibles, pour adultes  
hojas solidas reversibles, para adultos

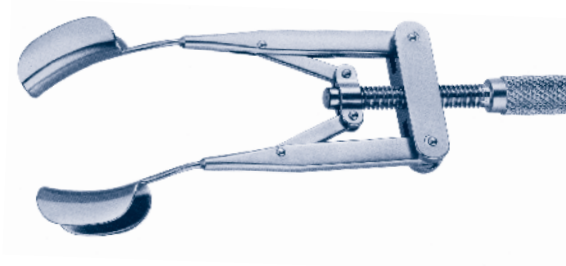
**SA60-1406-15**  
GINSBERG

15 mm

volle obere Valven und gefensterte untere Valven,  
für Erwachsene  
solid upper valves, fenestrated lower valves,  
for adults  
mors solides et fenestrées, pour adultes  
hojas solidas y fenestradas, para adultos

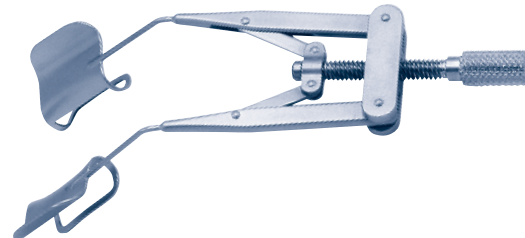
**SA60-1407-12**  
THORLAKSON

12 mm

O-Valven, ohne Spülung  
O-Wire, without irrigation  
O-oreilles, sans irrigation  
O-hojas, sin irrigación

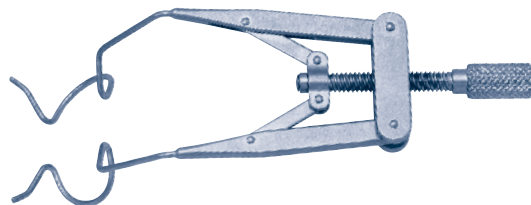
**1408-15**  
KERSHNER

15 mm

Gefensterte Valven, umkehrbar, für Erwachsene  
Fenestrated valves, reversible, for adults  
mors fenestrées réversibles, pour adultes  
Hojas fenestradas reversibles, para adultos

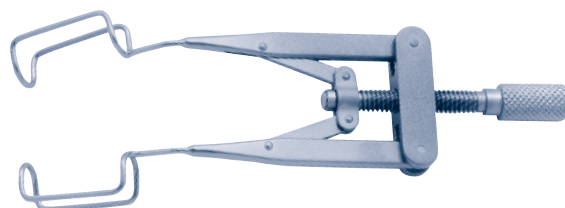

**SA60-1500-16**  
MELLINGER

15 mm

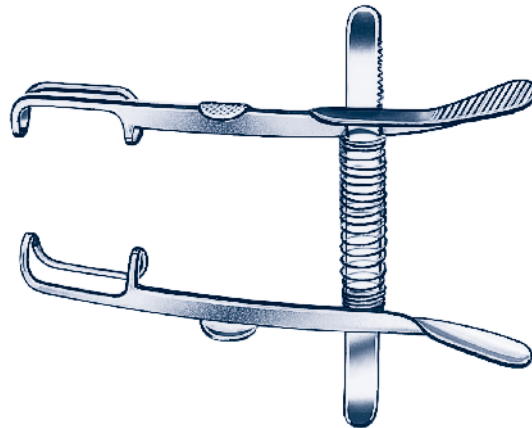
selbsthaltend, gefensterte Valven  
self-retaining, fenestrated valves  
auto-entretien, mors fenestrées  
hojas fenestradas**SA60-1501-16**  
MELLINGER-GIMBLE

15 mm

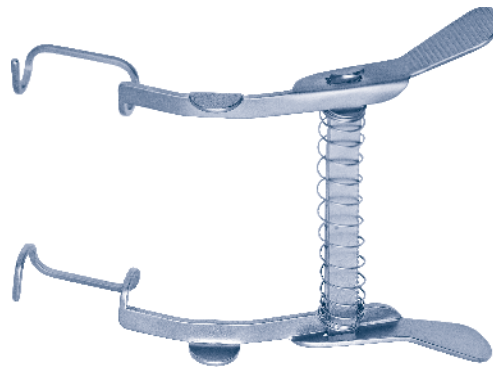
selbsthaltend, offene Valven  
self-retaining, open valves  
auto-entretien, oreilles ouvertes  
hojas abiertas**SA60-1503-16**  
MELLINGER-BEARD

15 mm

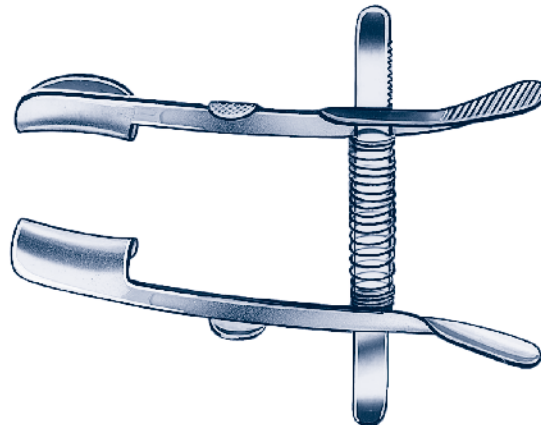
selbsthaltend, volle Valven  
self-retaining, solid valves  
auto-entretien, mors solides  
hojas solidas**SA60-1504-15**  
WEISS

15 mm

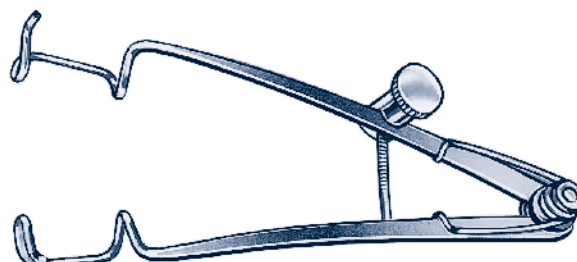
offene Valven  
open valves  
oreilles ouvertes  
hojas abiertas

**SA60-1505-15**  
**LANCASTER**

15 mm

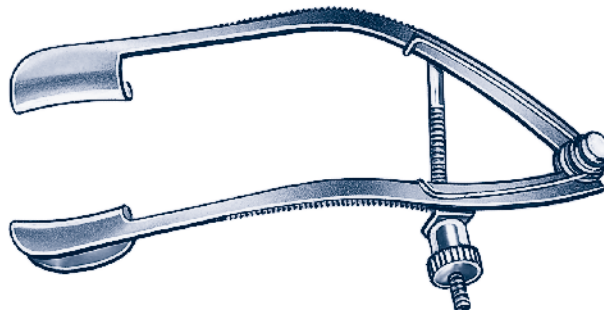
volle Valven  
solid blades  
mors solides  
hojas solidas**SA60-1511-14**  
**CASTROVIEJO**

14 mm

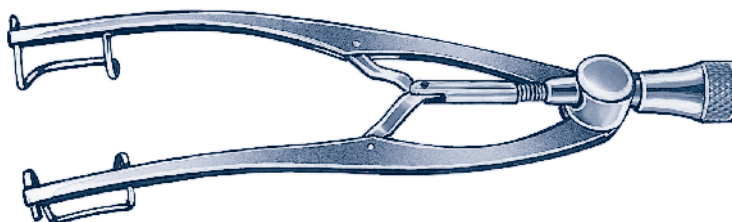
klein, gefensterte Valven  
small, fenestrated valves  
petit, mors fenestrées  
pequeno, hojas fenestradas**SA60-1512-16**  
**CASTROVIEJO**

16 mm

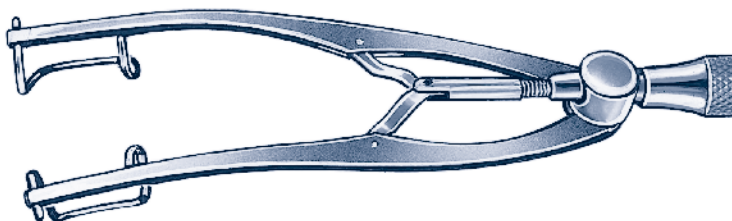
mittel, gefensterte Valven  
medium, fenestrated valves  
moyen, mors fenestrées  
medio, hojas fenestradas

**SA60-1515-02**

SAUER

2 mm

volle Valven für Frühgeborene  
solid blades for premature  
babies  
mors solides pour prématures  
hojas solidas para los bebes  
prematuros

**SA60-1515-04**

SAUER

4 mm

volle Valven für Säuglinge  
solid blades for infants  
mors solides pour nourrissons  
hojas solidas para lactantes

**SA60-1515-08**

SAUER

8 mm

volle Valven für Kinder  
solid blades for children  
mors solides pour enfants  
hojas solidas para niños

**SA60-1515-06**

SAUER

6 mm

volle Valven für Kinder  
solid blades for children  
mors solides pour enfants  
hojas solidas para niños

**SA60-1515-12**

SAUER

12 mm

volle Valven für Erwachsene  
solid blades for adults  
mors solides pour adultes  
hojas solidas para adultos



1515-12

**SA60-1516-22**

LESTER-BURCH

22 mm

volle Valven  
solid blades  
mors solides  
hojas solidas

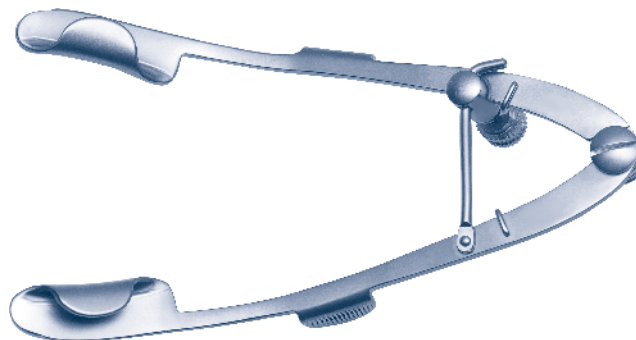

**SA60-1517-14**

WEISS

14 mm

klein, volle Valven, für Kinder  
small, solid valves, for children  
petit, mors solides, pour enfants  
pequeno, hojas solidas, para niños

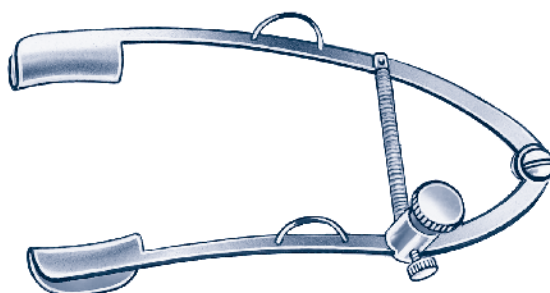

**SA60-1518-14**

WEISS

14 mm

klein, gefensterte Valven, für Kinder  
 small, fenestrated valves, for children  
 petit, mors fenestrées, pour enfants  
 pequeño, hojas fenestradas, para niños

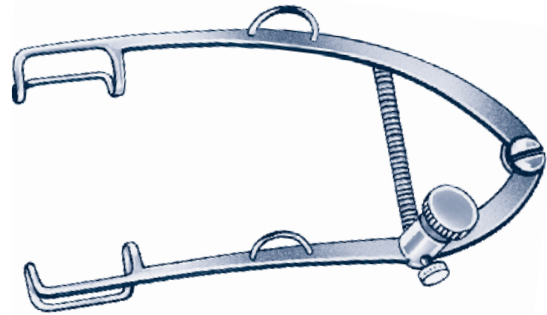
**SA60-1519-18**

WEISS

18 mm

gross, gefensterte Valven, für Erwachsene  
 large, fenestrated valves, for adults  
 grand, mors fenestrées, pour adultes  
 grande, hojas fenestradas, para adultos

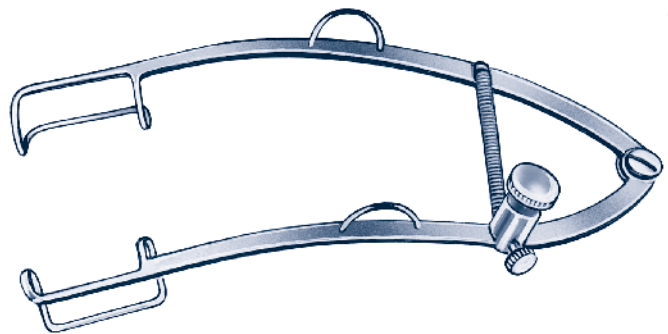
**SA60-1520-14**

WEISS

14 mm

klein, volle Valven, für Kinder  
 small, solid valves, for children  
 petit, mors solides, pour enfants  
 pequeño, hojas solidas, para niños

**SA60-1520-18**

WEISS

18 mm

gross, volle Valven, für Erwachsene  
 large, solid valves, for adults  
 grand, mors solides, pour adultes  
 grande, hojas solidas, para adultos

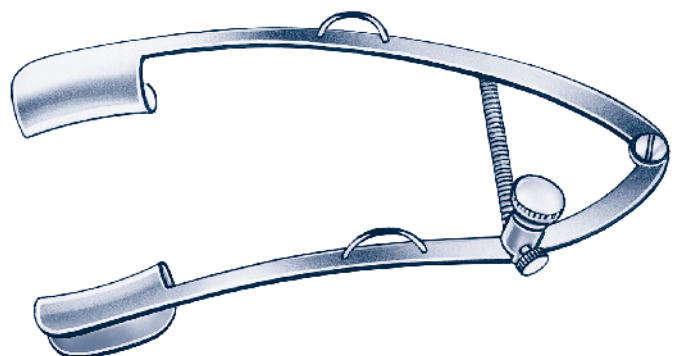

**SA60-1521-15**

CLARK

15 mm

offene Valven, für Erwachsene  
open valves, for adults  
oreilles ouvertes, pour adultes  
hojas abiertas, para adultos

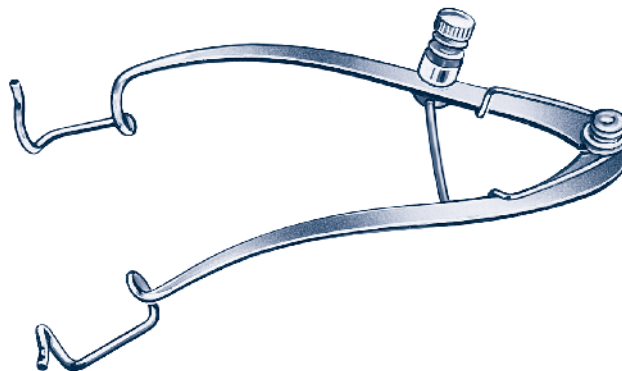
**SA60-1522-12**

MURDOCK

12 mm

gefensterte Valven, für Kinder  
fenestrated valves, for children  
mors fenestrées, pour enfants  
hojas fenestradas, para niños

**SA60-1522-15**

MURDOCK

15 mm

gefensterte Valven, für Erwachsene  
fenestrated valves, for adults  
mors fenestrées, pour adultes  
hojas fenestradas, para adultos

**SA60-1522R15**

MURDOCK

15 mm

rechts, gefensterte Valven, für  
Erwachsene  
right, fenestrated valves, for adults  
à droite, mors fenestrées, pour  
adultes  
a la derecha, hojas fenestradas,  
para adultos

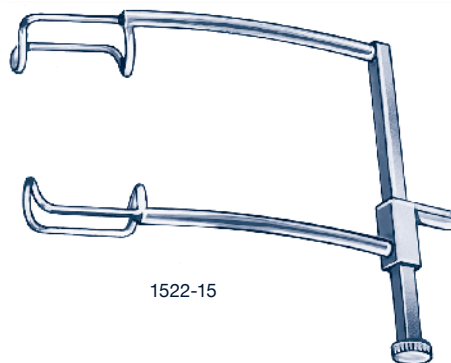
**SA60-1523-15**

MURDOCK

15 mm

mit Feststellschraube, gefensterte  
Valven, für Erwachsene  
with locking screw, fenestrated  
valves, for adults  
avec vis de serrage, mors  
fenestrées, pour adultes  
con fijación de rosca, hojas  
fenestradas, para adultos

**SA60-1525-14**  
**MAUMENEE-PARK**

14 mm  
volle Valven  
solid valves  
mors solides  
hojas solidas

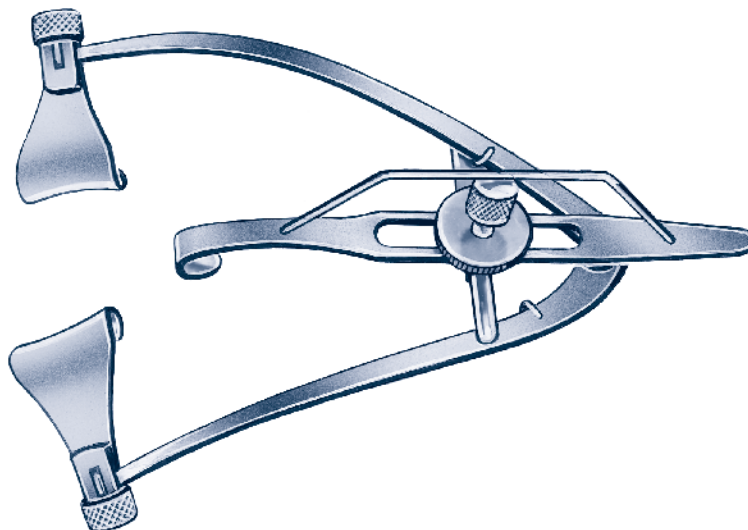

**SA60-1526-15**  
**PARK-GUYTON**

15 mm  
gefensterte Valven  
fenestrated valves  
mors fenestrées  
hojas fenestradas

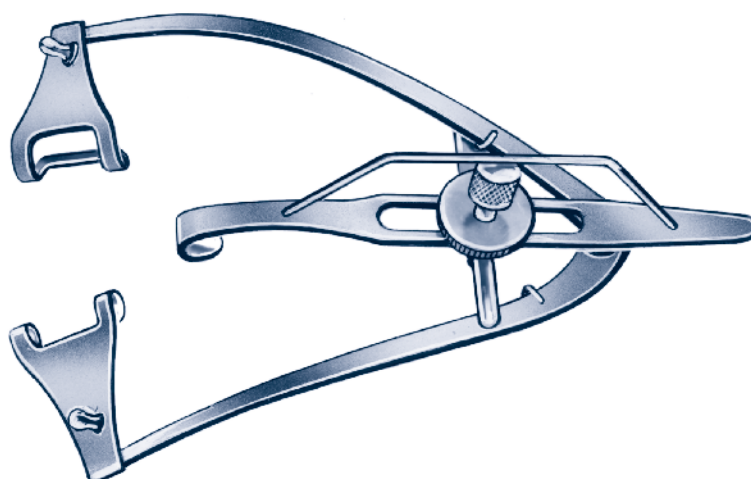

**SA60-1528-11**  
**BANGERTER**

11 mm  
volle Valven, für Kinder  
solid valves, for children  
mors solides, pour enfants  
hojas solidas, para niños

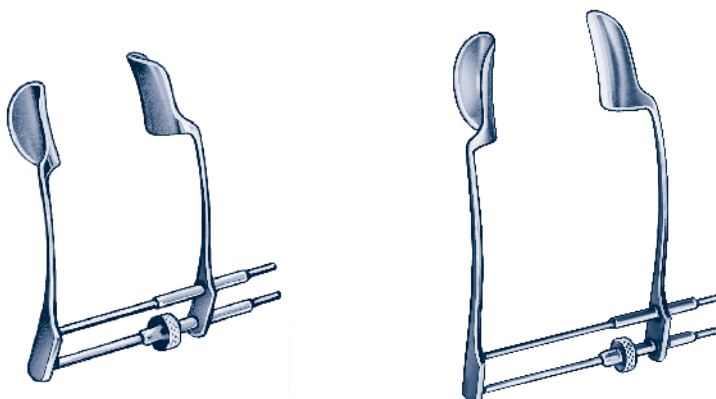

**SA60-1528-15**  
**BANGERTER**

15 mm  
volle Valven, für Erwachsene  
solid valves, for adults  
mors solides, pour adultes  
hojas solidas, para adultos

**SA60-1529-12****BARRAQUER**

12 mm

volle Valven, für Kinder  
solid blades, for children  
mors solides, pour enfants  
hojas solidas, para niños

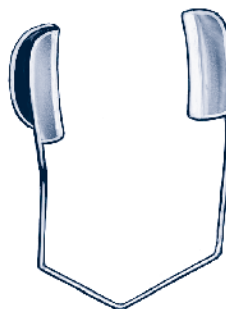
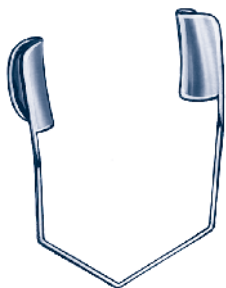
**SA60-1529-15****BARRAQUER**

15 mm

volle Valven, für Erwachsene  
solid blades, for adults  
mors solides, pour adultes  
hojas solidas, para adultos

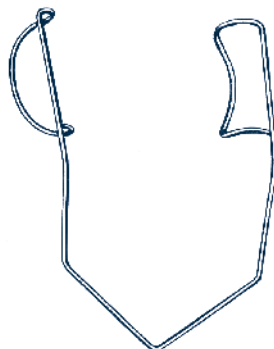
**SA60-1530-15****BARRAQUER**

15 mm

Standard Modell, für Erwachsene  
standard model, for adults  
modèle standard, pour adultes  
tipo standard, para adultos

**SA60-1530H15****BARRAQUER**

15 mm

extra stabil, für Erwachsene  
heavy wire, for adults  
modèle stable, pour adultes  
tipo fuerte, para adultos

**SA60-1531-04****BARRAQUER**

4 mm

runde Valven, für Säuglinge  
round valves, for infants  
mors rondes, pour nourrissons  
hojas rodondos, para lactantes

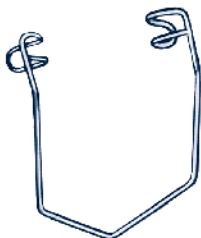
**SA60-1531-08****BARRAQUER**

8 mm

runde Valven, für Kinder  
round valves, for children  
mors rondes, pour enfants  
hojas rodondos, para niños

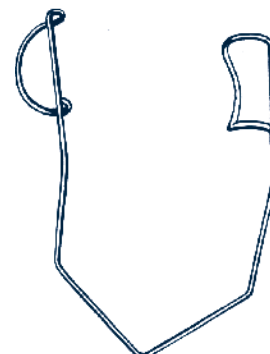
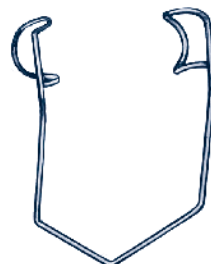
**SA60-1531-12****BARRAQUER**

12 mm

runde Valven, für Erwachsene  
round valves, for adults  
mors rondes, pour adultes  
hojas rodondos, para adultos

**SA60-1532-03**  
BARRAQUER

3 mm

Valven für Frühchen  
valves for premature infants  
mors pour prématurés  
hojas para pretérminos

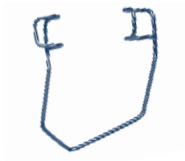

**SA60-1532-05**  
BARRAQUER

5 mm

Valven für Säuglinge  
valves for infants  
mors pour nourrissons  
hojas para lactantes

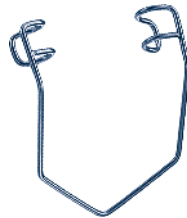

**SA60-1532-10**  
BARRAQUER

10 mm

Valven für Kinder  
valves for children  
mors pour enfants  
hojas para niños

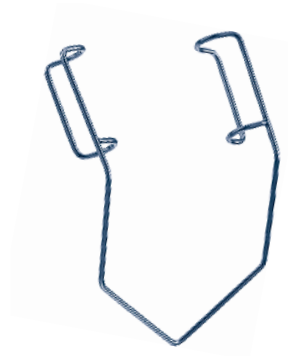
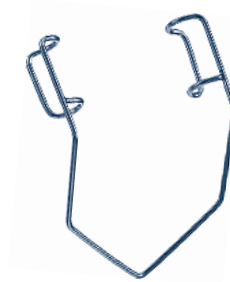

**SA60-1532-14**  
BARRAQUER

14 mm

Valven für Erwachsene  
valves for adults  
mors pour adultes  
hojas para adultos

**SA60-1533-11**  
BARRAQUER-OOSTERHUIS

11 mm

gefensterte Valven, verstellbar, für Kinder  
fenestrated valves, adjustable, for children  
mors fenestrées, ajustable, pour enfants  
hojas fenestradas, ajustable, para niños

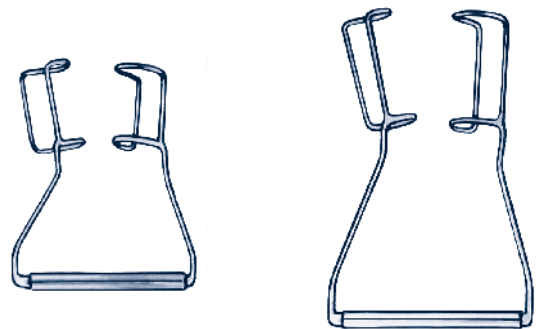

**SA60-1533-15**  
BARRAQUER-OOSTERHUIS

15 mm

gefensterte Valven, verstellbar, für Erwachsene  
fenestrated valves, adjustable, for adults  
mors fenestrées, ajustable, pour adultes  
hojas fenestradas, ajustable, para adultos

**SA60-1533B11**  
BARRAQUER-OOSTERHUIS

11 mm

gefensterte Valven, verstellbar, mit Stop, für Kinder  
fenestrated valves, adjustable, with stop, for children  
mors fenestrées, ajustable, avec stop, pour enfants  
hojas fenestradas, ajustable, con stop, para niños

**SA60-1533B15**  
BARRAQUER-OOSTERHUIS

15 mm

gefensterte Valven, verstellbar, mit Stop, für Erwachsene  
fenestrated valves, adjustable, with stop, for adults  
mors fenestrées, ajustable, avec stop, pour adultes  
hojas fenestradas, ajustable, con stop, para adultos

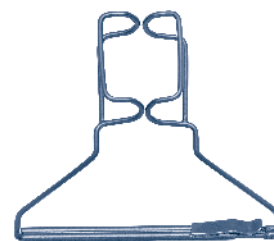

1533B15

**SA60-1538-15****BARRAQUER-OOSTERHUIS**

15 mm

volle Valven, verstellbar, für Erwachsene  
 solid valves, adjustable, for adults  
 mors solides, ajustable, pour adultes  
 hojas solidas, ajustable, para adultos

**SA60-1536-12****SCHOTT**

12 mm

gefensterte Valven, für Kinder  
 fenestrated valves, for children  
 mors fenestrées, pour enfants  
 hojas fenestradas, para niños

**SA60-1536-15****SCHOTT**

15 mm

gefensterte Valven, für Erwachsene  
 fenestrated valves, for adults  
 mors fenestrées, pour adultes  
 hojas fenestradas, para adultos

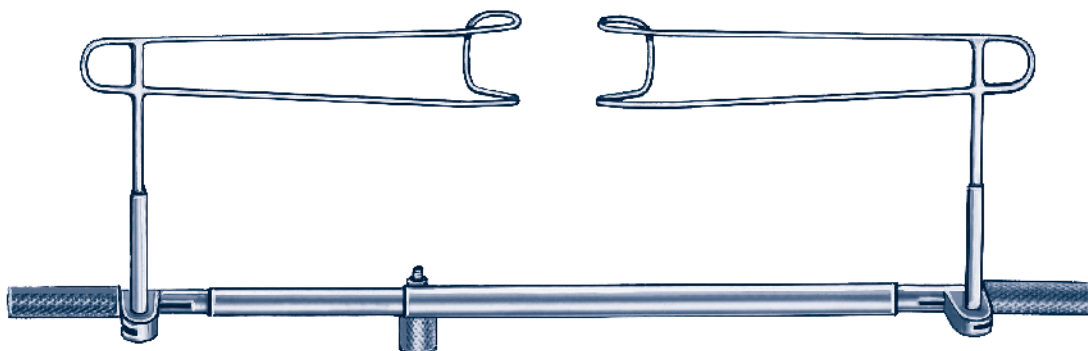
**SA60-1537-12****SCHOTT**

12 mm

volle Valven, für Kinder  
 solid valves, for children  
 mors solides, pour enfants  
 hojas solidas, para niños

**SA60-1537-15****SCHOTT**

15 mm

volle Valven, für Erwachsene  
 solid blades, for adults  
 mors solides, pour adultes  
 hojas solidas, para adultos

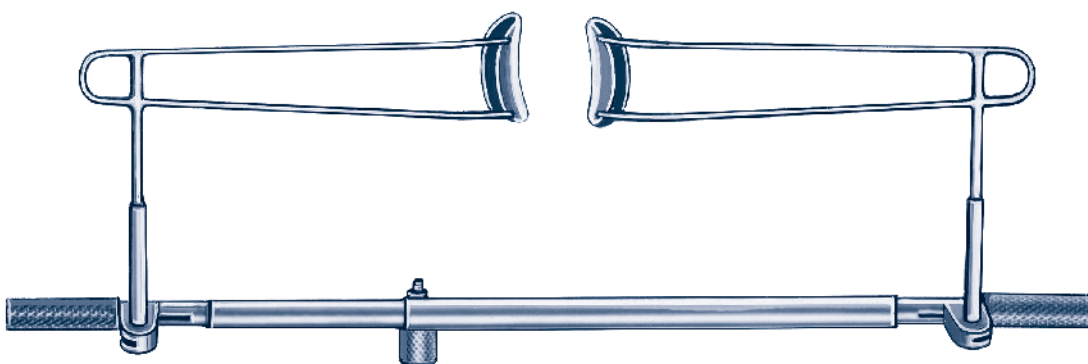

**SA60-1540-03**

COOK

3 mm

Valven für Frühchen  
valves for premature infants  
mors pour prématurés  
hojas para pretérminos

**SA60-1540-05**

COOK

5 mm

Valven für Neugeborene  
valves for newborn babies  
mors pour nouveaux-nés  
hojas para neonatos

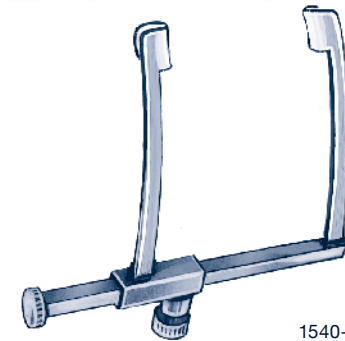

1540-05

**SA60-1540-08**

COOK

8 mm

Valven für Säuglinge  
valves for infants  
mors pour nourrissons  
hojas para lactantes

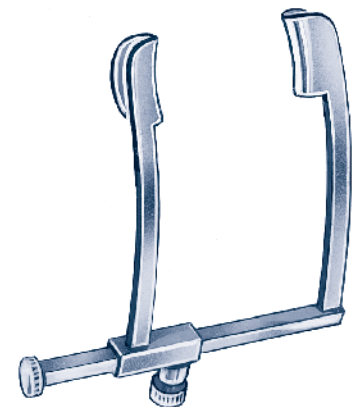
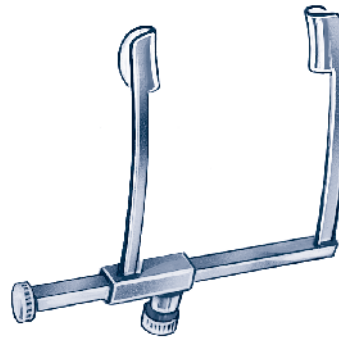

**SA60-1540-11**

COOK

11 mm

Valven für Kinder  
valves for children  
mors pour enfants  
hojas para niños

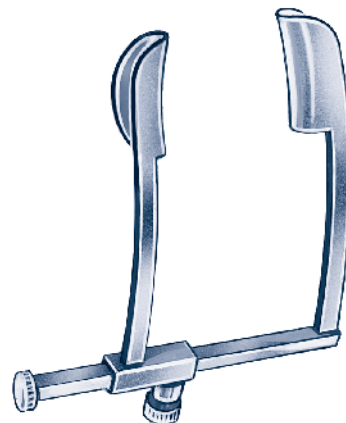

**SA60-1540-15**

COOK

15 mm

Valven für Erwachsene  
valves for adults  
mors pour adultes  
hojas para adultos

**SA60-1543-11****WILLIAMS**

11 mm

gefensterte/Valve für Kinder  
fenestrated/valves for children  
mors fenestrés pour enfants  
hojas fenestradas para niños

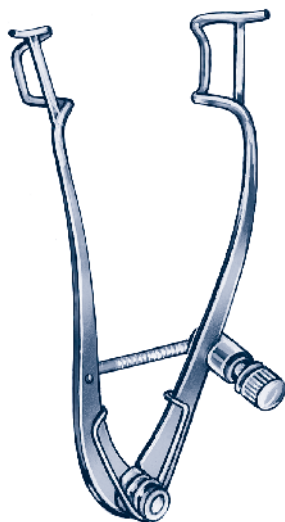
**SA60-1543-15****WILLIAMS**

15 mm

gefensterte/Valve für Erwachsene  
fenestrated/valves for adults  
mors fenestrés pour adultes  
hojas fenestradas para adultos

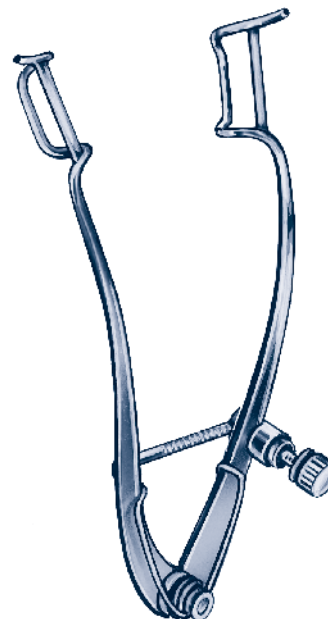
**SA60-1544-15****KRATZ-BARRAQUER**

15 mm

Valve für Erwachsene  
valves for adults  
mors pour adultes  
hojas para adultos

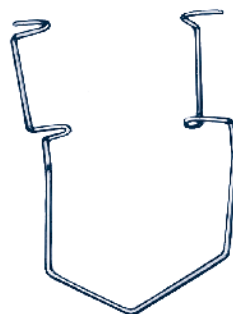
**SA60-1544N15****KRATZ-BARRAQUER**

15 mm

Valve nasale Anwendung für Erwachsene  
valves nasal placement for adults  
mors l'usage nasal pour adultes  
hojas aplicatiomasal para adultos

**SA60-1547-15****BARRAQUER**

15 mm

Valve, temporale Anwendung, für  
Erwachsene  
valves, temporal placement, for  
adults  
mors, l'usage temporal, pour adultes  
hojas, application temporal, para  
adultos

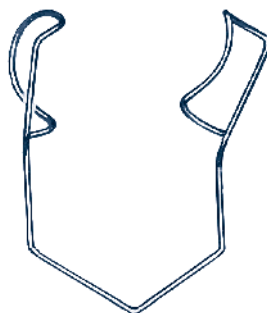

**SA60-1548-15**

McINTYRE

15 cm

geschlossene Valven für Erwachsene  
 closed valves for adults  
 mors pour adultes  
 hojas para adultos

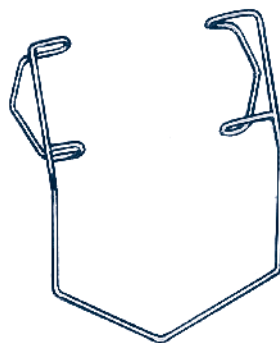
**SA60-1549-15**

McINTYRE

15 cm

offene Valven für Erwachsene  
 open valves for adults  
 mors pour adultes  
 hojas para adultos

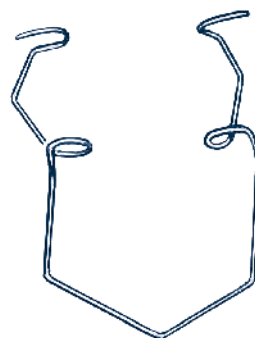
**SA60-1550-08**

ALFONSO

5 / 8 mm

gefensterte Valven für Neugeborene  
 fenestrated valves for newborn babies  
 mors fenestrées pour nouveaux-nés  
 hojas fenestradas para neonatos



**TRÄNENSACKSPREIZER**  
**LACRIMAL SAC RETRACTORS**

**ÉCARTEURS POUR LE SAC LACRIMAL**  
**SEPARADORES PARA EL SACO LACRIMAL**

**SA60-1551-11**  
**MUELLER**

Tränensackspreizer, 3 x 3 Zinken  
Lacrimal sac retractor, 3 x 3 prongs  
Ecarteur pour le sac lacrimon, 3 x 3 griffes  
Separador para el saco lacrimon, 3 x 3 púas

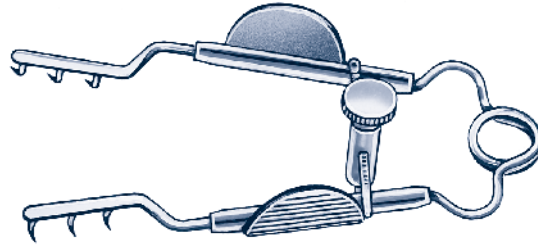

**SA60-1552-06**  
**AGRICOLA**

Tränensackspreizer, 3 x 3 Zinken  
Lacrimal sac retractor, 3 x 3 prongs  
Ecarteur pour le sac lacrimon, 3 x 3 griffes  
Separador para el saco lacrimon, 3 x 3 púas

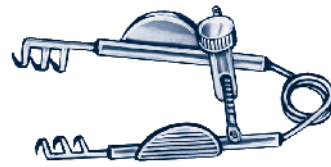

**SA60-1553-10**  
**STEVENSON**

Tränensackspreizer, 3 x 3 Zinken  
Lacrimal sac retractor, 3 x 3 prongs  
Ecarteur pour le sac lacrimon, 3 x 3 griffes  
Separador para el saco lacrimon, 3 x 3 púas

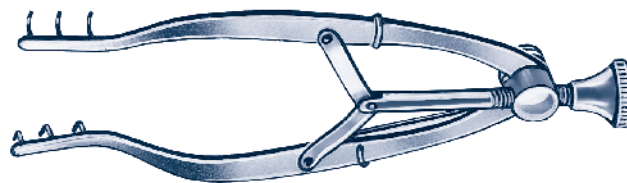

LIDHALTER  
LID RETRACTORS

RELEVEURS À PAUPIÈRES  
RETRACTORES PARA PÁRPADOS

**SA60-1651-05**  
DESMARRES  
5mm



**SA60-1651-08**  
DESMARRES  
8 mm



**SA60-1651-11**  
DESMARRES  
11 mm



**SA60-1651-14**  
DESMARRES  
14 mm



**SA60-1651-17**  
DESMARRES  
17 mm



**SA60-1655-13**  
SCHEPENS  
Orbitalspatel  
Orbital retractor  
Ecarteur orbiteur  
Retractor orbital



**SA60-1664-10**

## JAFTE

10 mm

Lidhalter für Kinder, einzeln erhältlich  
 Lid retractor, for children, sold separatly  
 Ecarteur de paupières, pour enfants, individuel  
 Retractor para párpados, para niños, solo



1664-15

**SA60-1664-15**

## JAFTE

15 mm

Lidhalter für Erwachsene, einzeln erhältlich  
 Lid retractor, for adults, sold separatly  
 Ecarteur de paupières, pour adultes, individuel  
 Retractor para párpados, para adultos, solo

**SA60-1666-15**

## TENNANT

15 mm

Lidhalter für Erwachsene, einzeln erhältlich  
 Lid retractor, for adults, sold separatly  
 Ecarteur de paupières, pour adultes, individuel  
 Retractor para párpados, para adultos, solo

**SA60-1670-11**

## JAEGER

Lidplatte  
 Lid plate  
 Plaque a paupieres  
 Placa para párpados



**SA60-1700-00****TYRELL**

Irishäkchen, scharf  
Iris hook, sharp  
Crochet a iris, pointu  
Gancho para iris, agudo

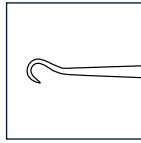
**SA60-1701-00****GRAEFE**

Irishäkchen, stumpf  
Iris hook, blunt  
Crochet a iris, mousse  
Gancho para iris, romo

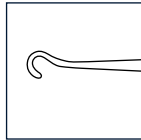
**SA60-1701-01****BONN**

Irishäkchen, stumpf  
Iris hook, blunt  
Crochet a iris, mousse  
Gancho para iris, romo

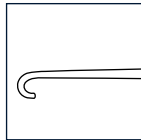
**SA60-1701-20****BONN**

Irishäkchen, stumpf, superfein  
Iris hook, blunt, extra delicate  
Crochet a iris, mousse, extra fine  
Gancho para iris, romo, muy  
delicado

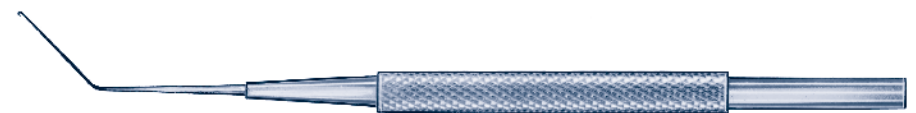
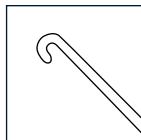
**SA60-1702-00****GUTHRIE**

Doppelhäkchen, scharf, klein  
Fixation hook, double prong, sharp, small  
Crochet double à fixation, pointu, petit  
Gancho doble para fijación, agudo,  
pequeño

**SA60-1703-00****GUTHRIE**

Doppelhäkchen, scharf, gross  
Fixation hook, double prong, sharp, large  
Crochet double à fixation, pointu, grand  
Gancho doble para fijación, agudo,  
grande



**SA60-1704-00**

## ROLLET

Tränensackhäkchen, 4 Zinken, scharf  
 Hook for lacrimal sack, 4 prongs, sharp  
 Crochet pour le sac lacrimonal, à 4 griffes,  
 pointu  
 Gancho para el saco lacrimonal, con 4 púas,  
 agudo

**SA60-1704-03**

## ROLLET

Tränensackhäkchen, 4 Zinken, stumpf  
 Hook for lacrimal sack, 4 prongs, blunt  
 Crochet pour le sac lacrimonal, à 4 griffes,  
 mousse  
 Gancho para el saco lacrimonal, con 4 púas,  
 romo

**SA60-1705-00**

## AUBARET

Tränensackhäkchen, 4 Zinken, scharf  
 Hook for lacrimal sack, 4 prongs, sharp  
 Crochet pour le sac lacrimonal, à 4 griffes,  
 pointu  
 Gancho para el saco lacrimonal, con 4 púas,  
 agudo

**SA60-1708-00**

## AXENFELD

Tränensackhäkchen, 2 Zinken, scharf  
 Hook for lacrimal sack, 2 prongs, sharp  
 Crochet pour le sac lacrimonal, à 2 griffes,  
 pointu  
 Gancho para el saco lacrimonal, con 2  
 púas, agudo

**SA60-1709-00**

## AXENFELD

Tränensackhäkchen, 2 Zinken, stumpf  
 Hook for lacrimal sack, 2 prongs, blunt  
 Crochet pour le sac lacrimonal, à 2 griffes,  
 mousse  
 Gancho para el saco lacrimonal, con 2  
 púas, romo

**SA60-1710-00**

## AXENFELD (KNAPP)

Tränensackhäkchen, 3 Zinken, scharf  
 Hook for lacrimal sack, 3 prongs, sharp  
 Crochet pour le sac lacrimonal, à 3 griffes,  
 pointu  
 Gancho para el saco lacrimonal, con 3  
 púas, agudo

**SA60-1711-00**

## AXENFELD (KNAPP)

Tränensackhäkchen, 3 Zinken, stumpf  
 Hook for lacrimal sack, 3 prongs, blunt  
 Crochet pour le sac lacrimonal, à 3 griffes,  
 mousse  
 Gancho para el saco lacrimonal, con 3  
 púas, romo



**SA60-1714-03**

CLAYMAN

IOL-Häkchen  
 IOL-Hook  
 Crochet manipulateur  
 pour IOL  
 Gancho para manipulación  
 de IOL

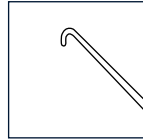
**SA60-1716-10**

JAEGER

Schielhäkchen, klein  
 Strabismus hook, small  
 Crochet à strabisme, petit  
 Gancho para estrabismo, pequeño

**SA60-1717-10**

GRAEFE

Schielhäkchen, klein  
 Strabismus hook, small  
 Crochet à strabisme, moyen  
 Gancho para estrabismo, pequeño

**SA60-1717-20**

GRAEFE

Schielhäkchen, mittel  
 Strabismus hook, medium  
 Crochet à strabisme, grand  
 Gancho para estrabismo, mediano

**SA60-1717-30**

GRAEFE

Schielhäkchen, groß  
 Strabismus hook, large  
 Crochet à strabisme, grand  
 Gancho para estrabismo, grande



**SA60-1718-20**

BONN

Schielhäkchen  
 Strabismus hook  
 Crochet à strabisme  
 Gancho para estrabismo

**1719-00**

JAMESON

Schielhäkchen, klein  
 Strabismus hook, small  
 Crochet à strabisme, petit  
 Gancho para estrabismo, pequeño

**SA60-1719-10**

JAMESON

Schielhäkchen, groß  
 Strabismus hook, large  
 Crochet à strabisme, petit  
 Gancho para estrabismo, grande

**SA60-1721-00**

GREEN

Schielhäkchen  
 Strabismus hook  
 Crochet à strabisme  
 Gancho para estrabismo

**SA60-1722-00**

STEVENS

Linsenhäkchen  
 Lens hook  
 Crochet pour lentes  
 Gancho para lentes



**SA60-1723-06**  
HELVESTON

6 mm  
Häkchen, sehr fein, stumpf  
'Teaser' hook, delicate, blunt  
Crochet ,teaser', extra fine, mousse  
Gancho ,teaser', muy delicado, romo



**SA60-1723-12**  
HELVESTON

12 mm  
Häkchen  
Hook  
Crochet  
Gancho



**SA60-1724-00**  
GASS

Häkchen bei Netzhautablösung,  
mit Loch  
Retinal detachment hook, with  
hole  
Crochet à décollement de  
retine, avec trou  
Gancho para desprendimiento  
de Retina



**SA60-1730-00**  
ARRUGA

Starhaken, rechts  
Extraction hook, right  
Crochet pour extraction, a droite  
Gancho para extracción, derecha



**SA60-1731-00**  
ARRUGA

Starhaken, links  
Extraction hook, left  
Crochet pour extraction, a gauche  
Gancho para extracción, izquierda



**SA60-1734-02**  
SINSKEY

0,2 mm  
Linsenhäkchen, abgewinkelt  
Lens hook, angled,  
Crochet pour IOL, coude,  
Gancho para lentes intraoculares,  
angulado

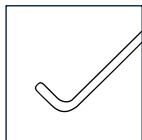

**SA60-1735-02**  
SINSKEY

0,2 mm  
Linsenhäkchen, gerade  
Lens hook, straight  
Crochet pour IOL, droit  
Gancho para lentes intraoculares,  
recto

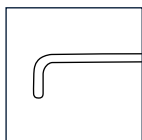

**SA60-1736-02**  
CLAYMAN

0,2 mm  
Linsenhäkchen, abgewinkelt  
Lens hook, angled  
Crochet pour IOL, coude  
Gancho para lentes intraoculares,  
angulado

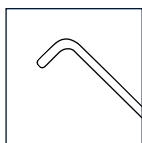

**SA60-1738-00**  
KUGLEN

Linsenmanipulator, gerade  
Lens manipulator, straight  
Crochet a implant, droit  
Gancho para lentes intraoculares,  
recto

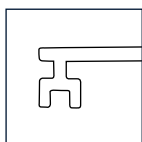

**SA60-1739-00**  
KUGLEN

Linsenmanipulator, abgewinkelt  
Lens manipulator, angled  
Crochet a implant, coude  
Gancho para lentes intraoculares,  
angulado

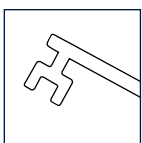

**SA60-1740-00**  
**DARDENNE**

Irishäkchen, „push-pull“, abgewinkelt  
Iris hook, “push-pull“, angled  
Crochet a iris, «push-pull», coude  
Gancho para iris, “push-pull“, angulado

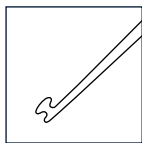

**SA60-1762-00**  
**PFAEFFL**

Femtoflaplifter, V-Haken und  
modifiziertes Sinskey Häkchen  
Femto flap lifter, V-shaped hook and  
modified Sinskey hook  
Femto flap lifter, Crochet en forme de  
„V“ et crochet modifié de Sinskey  
Femto flap lifter, Gancho en forma de  
„V“ y gancho modificado de Sinskey

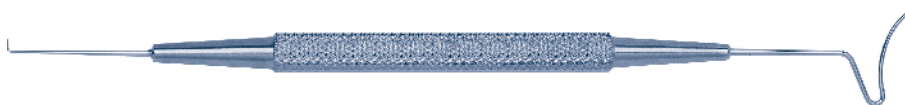
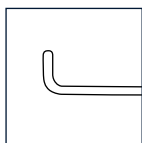

**SA60-1763-00**  
**STEINMETZ**

1,0 mm

Spatel, zur manuellen Kernfragen-  
tation, für die rechte Hand  
Spatula, for manual nucleus  
fragmentation, for use in right hand  
Spatule, pour diviser de noyau, pour  
la droite  
Espátula, para dividir el nucleo, para  
la mano derecha

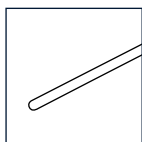

**SA60-1763-01**  
**STEINMETZ**

1,0 mm

Spatel, zur manuellen Kernfragen-  
tation, für die linke Hand  
Spatula, for manual nucleus  
fragmentation, for use in left hand  
Spatule, pour diviser de noyau, pour  
la gauche  
Espátula, para dividir el nucleo, para  
la mano siniestra

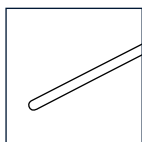

**SA60-1765-60**  
**KAGAWA**

Nukleusspalter, 60°  
Nucleus dividing hook, 60°  
Phaco cliveur, 60°  
Gancho para separación de  
núcleo, 60°



**SA60-1765-90**  
**KAGAWA**

Nukleusspalter, 90°  
Nucleus dividing hook, 90°  
Phaco cliveur, 90°  
Gancho para separación de  
núcleo, 90°



**SA60-1767-50**

**JAFFE**

Linsen-Spatel, 0,5 mm breit  
 Lens spatula, 0,5 mm wide  
 Spatule pour la lentille cristalline,  
 0,50 mm  
 Espátula para el cristalino, 0,5 mm  
 de ancho

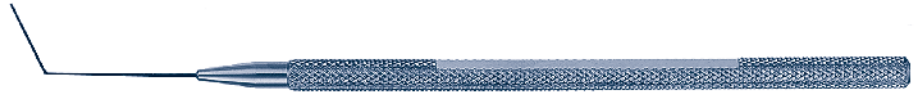
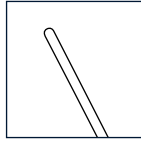

**SA60-1768-50**

**HIRSCHMANN**

Linsen-Spatel, mit Kerben  
 Lens spatula, with notches  
 Spatule pour la lentille cristalline  
 Espátula para el cristalino, con  
 ranuras

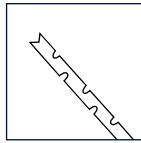

**SA60-1770-00**

**KNOLLE**

Iris-Häkchen, gerade, stumpf  
 Iris hook, straight, blunt tip  
 Crochet a iris, droit, mousse  
 Gancho para iris, recto, romo

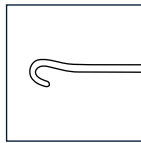

**SA60-1771-00**

**JAFFE-KNOLLE**

Iris-Häkchen, abgewinkelt, stumpf  
 Iris hook, angled, blunt tip  
 Crochet a iris, coude, mousse  
 Gancho para iris, angulado, romo

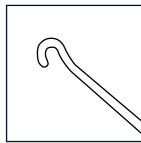

**SA60-1773-15**

**KOCH**

1,5 mm  
 Manipulator, „Stop and Chop“,  
 gewinkelt  
 Nucleus manipulator, “stop and  
 chop“, angled  
 Manipulateur, „stop and chop“,  
 coude  
 Manipulador, „stop and chop“,  
 angulado

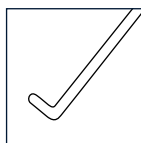

**SA60-1775-15**

**FENZL**

0,15 mm

Linsenmanipulator, gerade  
 Lens manipulator, straight  
 Manipulateur, droit  
 Manipulador, recto

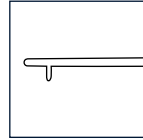

**SA60-1776-00**

**KUGLEN**

Linsenmanipulator und -häkchen,  
 „push-pull“ Modell, abgewinkelt  
 Lens manipulator and hook,  
 “push-pull” model, angled  
 Manipulateur et crochet a iris,  
 „push-pull“ model, coude  
 Manipulador y gancho para iris,  
 modelo „push-pull“, angulado

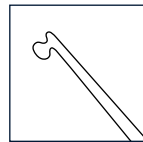

**SA60-1777-20**

**SINSKEY**

0,20 mm

Linsenhäkchen, gerade,  
 Lens hook, straight  
 Crochet pour IOL, droit  
 Gancho para lentes intraoculares,  
 recto

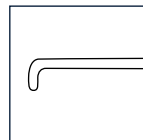

**SA60-1778-20**

**SINSKEY**

0,20 mm

Linsenhäkchen, abgewinkelt  
 Lens hook, angled  
 Crochet pour IOL, coude  
 Gancho para lentes intraoculares,  
 angulado

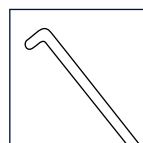

**SA60-1778-25**  
SINSKEY

0,25 mm  
Linsenhäkchen, abgewinkelt  
Lens hook, angled  
Crochet pour IOL, coude  
Gancho para lentes intraoculares,  
angulado

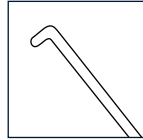

**SA60-1779-25**  
LESTER

0,25 mm  
IOL-Manipulator, gerade  
IOL-Manipulator, straight  
Manipulateur pour IOL, droit  
Manipulador pour IOL, recto

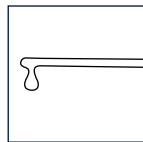

**SA60-1779-50**  
LESTER

0,25 mm  
IOL-Manipulator, abgewinkelt  
IOL-Manipulator, angled  
Manipulateur pour IOL, coude,  
Manipulador pour IOL, angulado

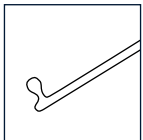

**SA60-1779-75**  
LESTER

0,25 mm  
IOL-Manipulator, abgewinkelt und  
gewölbt  
IOL-Manipulator, angled, vaulted  
shank  
Manipulateur pour IOL, coude et  
voûté  
Manipulador pour IOL, angulado y  
curvo

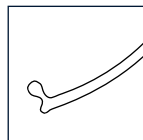

**SA60-1781-00**

NEUHANN

Linsenkernrotierer und Kernspalter  
 Nucleus rotator and dividing hook  
 Crochet manipulateur de noyau et diviseur à noyau  
 Rotador para núcleo y divisor de núcleo

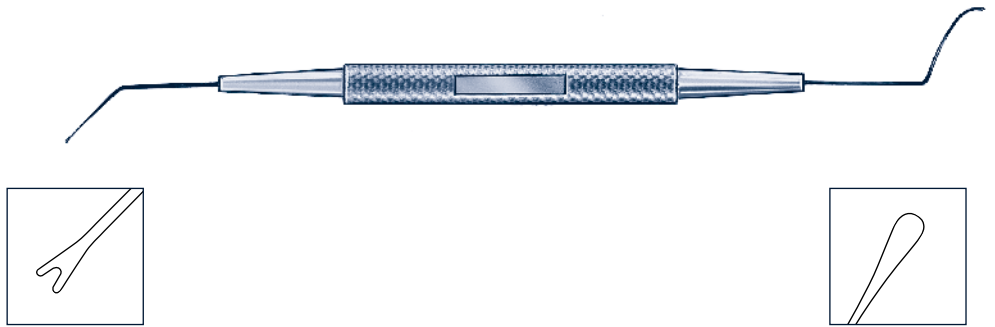

**SA60-1781-01**

NEUHANN

Irishäkchen Push-Pull und Kernspalter  
 Push-Pull Iris Hook push-pull and nucleus dividing hook  
 Crochet a iris push-pull et diviseur à noyau  
 Gancho para iris push-pull y divisor de núcleo

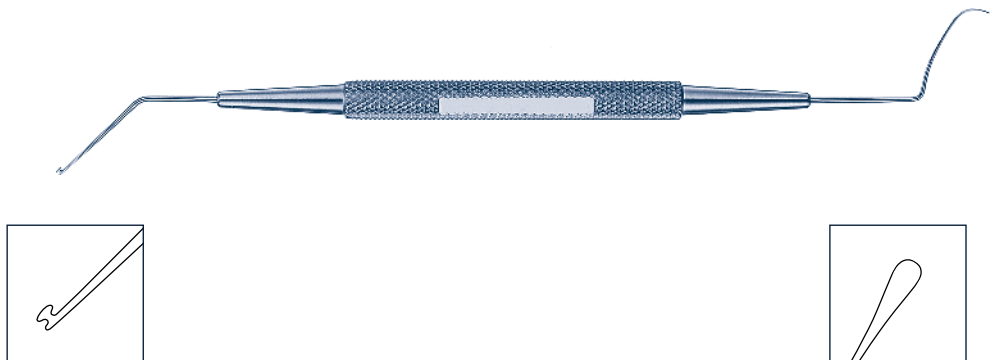

**SA60-1781-02**

NEUHANN

Kernspalter und Linsenspatel  
 Nucleus dividing hook and lens spatula  
 Diviseur à noyau et spatule pour la lentille cristalline  
 Divisor de núcleo y espátula para el cristalino

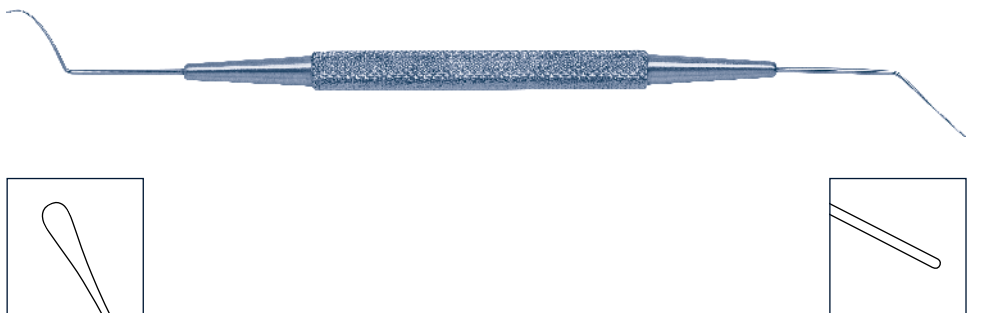

**SA60-1781-03**

HOFFMANN

Kernspalter und Linsenkernrotierer  
 Nucleus dividing hook and nucleus rotator  
 Diviseur à noyau et crochet manipulateur de noyau  
 Divisor de núcleo y rotador de núcleo

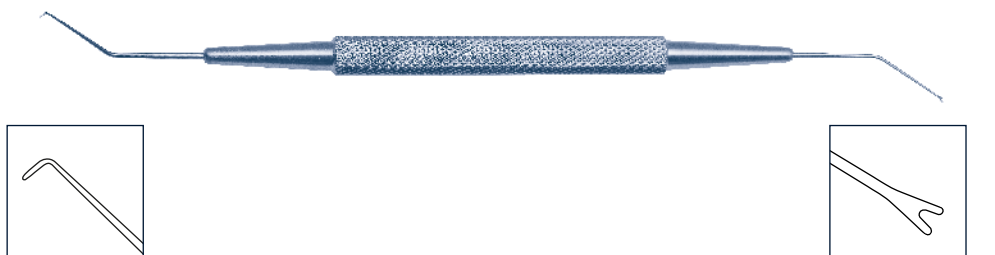

**SA60-1782-00**  
NEUHANN

Linsenkernrotierer  
Nucleus rotator  
Crochet manipulateur de noyau  
Rotador de núcleo

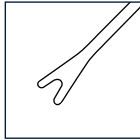

**SA60-1783-00**  
BECHERT

Linsenkernrotierer, Original Modell  
Nucleus rotator, original model  
Crochet manipulateur de noyau,  
modele original  
Rotador de núcleo, modelo original

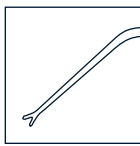

**SA60-1783-01**  
BECHERT

Linsenkernrotierer, Gabel 90° gedreht  
Nucleus rotator, fork 90° twisted  
Crochet manipulateur de noyau,  
fourche 90° tournée  
Rotador de núcleo, horquilla con  
torsión de 90°

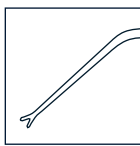

**SA60-1783-02**  
BECHERT

Linsenkernrotierer, gerade  
Nucleus rotator, straight  
Crochet manipulateur de noyau,  
droite  
Rotador de núcleo, recto

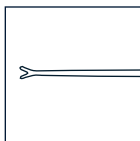

**SA60-1784-50**  
CLAYMAN

Linsenkernrotierer, abgewinkelt  
Nucleus rotator, angled  
Crochet manipulateur de noyau,  
coude  
Rotador de núcleo, angulado

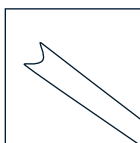

**SA60-1785-00**

**KOCH**

Nukleusspalter  
Nucleus splitter  
Crochet diviseur à noyau  
Gancho para separación de núcleo

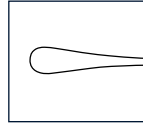

**SA60-1786-00**

**ROSEN**

Nukleusspalter, stumpfe Spitze  
Nucleus splitter, blunt tip  
Crochet diviseur à noyau, bord mousse  
Gancho para separación de núcleo, punta roma

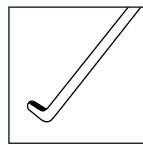

**SA60-1787-00**

**GRAETHER**

Kragenknopf Irisretraktor  
Iris retractor with collar button  
Rétracteur d'iris „bouton de col“  
Retractor para iris, boton en el cuello

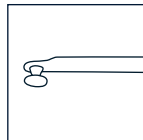

**SA60-1787-45**

**GRAETHER**

Kragenknopf Irisretraktor, 45°  
abgewinkelt  
Iris retractor with collar button,  
45° angled  
Rétracteur d'iris „bouton de col“,  
45° coude  
Retractor para iris, boton en el  
cuello, 45° angulado

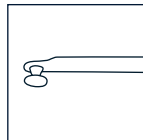

1787-00

**SA60-1788-50**

**LUND**

Irishäkchen, abgewinkelt  
Iris hook, angled  
Crochet a iris, coude  
Gancho para iris, angulado

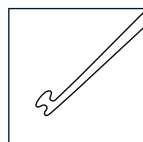

**SA60-1789-50**

**ANIS**

0,5 mm  
Kernmanipulator  
Nucleus manipulator  
Crochet manipulateur  
Manipulador de núcleo de lente

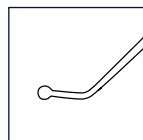

**SA60-1790-20**

JACOBI

Repositionshäkchen, für 0,2 mm IOL-Loch  
 Reposition hook, for 0,2 mm IOL hole  
 Crochet a reposition, pour trou de 0,20 mm  
 Gancho de reposición, para ojo de 0,20 mm

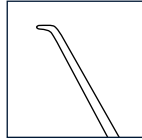

**SA60-1790-30**

JACOBI

Repositionshäkchen, für 0,3 mm IOL-Loch  
 Reposition hook, for 0,3 mm IOL hole  
 Crochet a reposition, pour trou de 0,30 mm  
 Gancho de reposición, para ojo de 0,30 mm

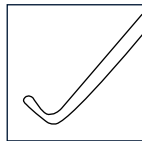

**SA60-1791-01**

LIEBERMANN

Mikrofinger, für die rechte Hand  
 Micro Finger, for use in right hand  
 Micro manipulateur à noyau, main droite  
 Micro Finger manipulador para núcleo de lente, mano derecha

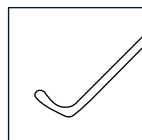

**SA60-1791-02**

LIEBERMANN

Mikrofinger, für die linke Hand  
 Micro Finger, for use in left hand  
 Micro manipulateur à noyau, main gauche  
 Micro Finger manipulador para núcleo de lente, mano izquierda

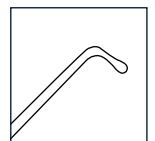
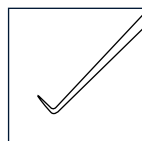

**SA60-1792-01**

CHANG

Phako Chopper, doppelendig, für die linke Hand  
 Phaco Chopper, double ended, for use in left hand  
 Micro manipulateur à noyau doubles, main gauche  
 Micro Finger manipulador doble para núcleo de lente, mano izquierda

**SA60-1793-00**  
**NAGAHARA**

Linsenspatel  
Lens spatula  
Spatule pour cristallin  
Espátula para cristalino

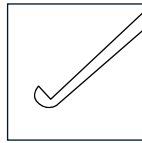

**SA60-1794-00**  
**FUKASAKU**

„snap & split“  
Häkchen  
Hook  
Crochet  
Gancho

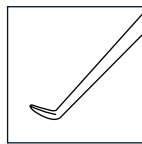

**SA60-1795-00**  
**DRYSDALE**

Kernmanipulator und Kapselpolierer  
Nucleus manipulator and capsule  
polisher  
Crochet pour manipulation du noyau  
et polissoir capsulaire  
Manipulador para núcleo de lente y  
pulidor para cápsula

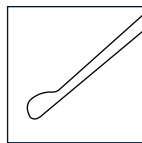

**SA60-1796-01**  
**PISACANO**

Linsenkernrotierer, horizontal  
Nucleus rotator, horizontal  
Crochet pour manipulation du noyau,  
horizontal  
Rotador para núcleo de lente,  
horizontal

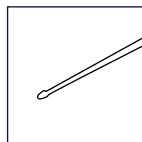

**SA60-1796-02**  
**PISACANO**

Linsenkernrotierer, vertikal  
Nucleus rotator, vertical  
Crochet pour manipulation du noyau,  
vertical  
Rotador para núcleo de lente, vertical

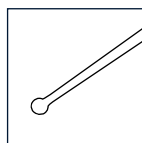

**SA60-1797-01**

**RENTSCH**

Linsenmanipulator, Typ „Bootshaken“, gerade  
 Nucleus rotator, „Boat hook“, straight  
 Crochet pour manipulation du lentille, „Boat hook“, droit  
 Manipulador de lentes, „Boat hook“, recto

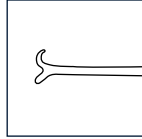

**SA60-1797-02**

**MALTZMAN-FENZL**

Linsenmanipulator, abgewinkelt  
 Lens manipulator, angled  
 Crochet pour manipulation du lentille, coude  
 Manipulador de lentes, angulado

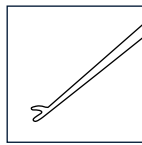

**SA60-1798-00**

**NAGAHARA**

Nucleus Chopper

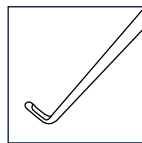

**SA60-1798-01**

**NAGAHARA**

Nucleus Chopper, für die linke Hand  
 Nucleus Chopper, for left hand  
 Nucleus Chopper, main gauche  
 Nucleus Chopper, mano izquierda

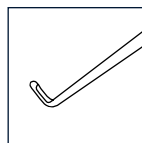

**SA60-1798-02**

**NAGAHARA**

Nucleus Chopper, für die rechte Hand  
 Nucleus Chopper, for right hand  
 Nucleus Chopper, main droite  
 Nucleus Chopper, mano derecha

**SA60-1799-00**

**HÄFLIGER**

Kernspalter, stumpf, für die rechte Hand  
 Nucleus dividing hook, blunt, for right hand  
 Manipulateur à Phaco-emulsification, émoussée, main droite  
 Micromanipulador para faco, romo, mano derecha

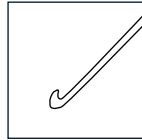

**SA60-1799-01**

**HÄFLIGER**

Kernspalter, stumpf, für die linke Hand  
 Nucleus dividing hook, blunt, for left hand  
 Manipulateur à Phaco-emulsification, émoussée, main gauche  
 Micromanipulador para faco, romo, mano izquierda

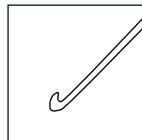

**SA60-1799-30**

**HÄFLIGER**

Kernspalter, scharf, für die rechte Hand  
 Nucleus dividing hook, sharp, for right hand  
 Manipulateur à Phaco-emulsification, tranchant, main droite  
 Micromanipulador para faco, afilado, mano derecha

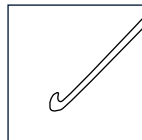

**SA60-1799-31**

**HÄFLIGER**

Kernspalter, scharf, für die linke Hand  
 Nucleus dividing hook, sharp, for left hand  
 Manipulateur à Phaco-emulsification, tranchant, main gauche  
 Micromanipulador para faco, afilado, mano izquierda

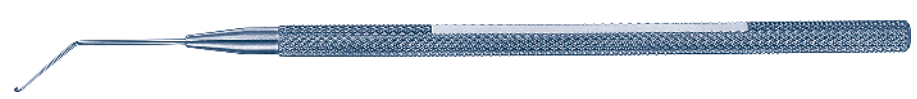
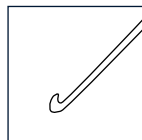

## SKALPELLE / MESSER

## SCALPELS / KNIVES

## BISTOURIS / COUTEAUX

## BISTURÍES / CUCHILLOS

Augenskalpell, geballt  
Scalpel, convex Bistouri,  
convexe Bisturi hoja,  
convexa

**SA60-1800-13** 13 mm  
**SA60-1800-20** 20 mm



1800-20

Augenskalpell, spitz  
Scalpel, pointed Bistouri,  
pointu Bisturi hoja, aguda

**SA60-1802-13** 13 mm  
**SA60-1802-16** 16 mm  
**SA60-1802-18** 18 mm  
**SA60-1802-25** 25 mm



1802-18

### SA60-1810-02

Diamantmesser mit einschneidigem  
Diamant  
Diamond knife, one cutting edge  
Couteau de diamant, lame avec un  
tranchant Bisturi de diamante con un  
corte

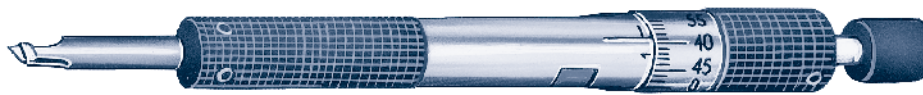

vergrößert  
enlarged  
agrandi  
agrandando

### SA60-1811-02

Diamantmesser mit zweischneidigem  
Diamant  
Diamond knife, two cutting  
edges  
Couteau de diamant, lame avec deux  
tranchants  
Bisturi de diamante con dos cortes



vergrößert  
enlarged  
agrandi  
agrandando

Andere Modelle auf Wunsch erhältlich  
Other models available  
Autres modèles sur demande  
Otros modelos, sobre demande

### SA60-1825-15

#### TOOKE

Hornhautmesser  
Corneal knife  
Couteau pour la cornée  
Queratótomo



### GRAEFE

Skleramesser,  
Scarifier  
Scarificateur  
Escarificador

**SA60-1830-04** 4 mm  
**SA60-1830-06** 6 mm  
**SA60-1830-10** 10 mm



1830-10

### SA60-1832-02

#### GOLF CLUB

Fremdkörpermesser  
Foreign body spud  
Couteau à corps étrangers  
Cuchillo para cuerpos extraños

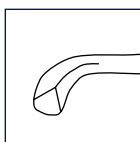

**SA60-1834-02****FRANCIS**

Fremdkörpermesser  
Foreign Body Knife  
Couteau à corps étrangers  
Cuchillo para cuerpos extraños

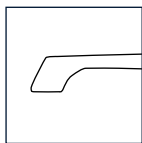
**SA60-1836-00****GILL**

Hornhautmesser, gerade  
Corneal knife, straight  
Couteau pour la cornée, droite  
Queratótomo, recto



1836-00

**SA60-1837-00****GILL**

Hornhautmesser, leicht gebogen  
Corneal knife, slightly curved  
Couteau pour la cornée, courbe  
Queratótomo, curvo

**SA60-1838-00****PATON**

Skleramesser  
Scarifier  
Scarificateur  
Escarificador

**SA60-1840-25****GRAEFE**

25 mm x 1,5 mm

Starmesser  
Cataract knife  
Couteau à cataracte  
Cuchillo para cataratas

**SA60-1840-30****GRAEFE**

30 mm x 2,0 mm

Starmesser  
Cataract knife  
Couteau à cataracte  
Cuchillo para cataratas

**SA60-1854-03**  
**DARDENNE**

Satomesser  
Sato knife  
Couteau Sato  
Cuchillo Sato

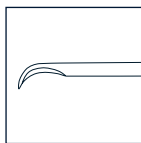

**SA60-1855-00**  
**SATO**

Hornhautmesser  
Corneal knife  
Couteau pour la cornée  
Queratótomo

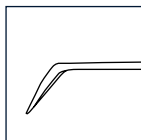

**SA60-1882-10**  
JAEGER

Lanzenmesser, 45°  
abgewinkelt, klein  
Keratome, 45° angled,  
small  
Couteau lanceolaire,  
coude 45°, petit  
Cuchillo lanceolar,  
angulado 45°, pequeño

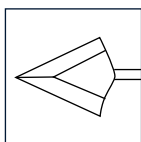

**SA60-1882-20**  
JAEGER

Lanzenmesser, 45°  
abgewinkelt, groß  
Keratome, 45° angled,  
large  
Couteau lanceolaire,  
coude 45°, grand  
Cuchillo lanceolar,  
angulado 45°, grande



**SA60-1893-21** (2,1 mm)  
**SA60-1893-28** (2,8 mm)  
**SA60-1893-32** (3,2 mm)  
**SA60-1893-35** (3,5 mm)

Phako-Lanze  
Phaco keratome Keratomes  
lanceolaire de phaco  
Queratótomo de phaco

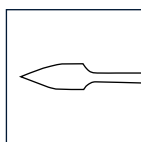

**SA60-1894-00**  
HAMBURG

Luftlanze  
Keratome  
Keratome lanceolaire  
Queratótomo

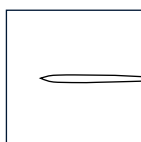

**SA60-1900-15**

R. KOCH

19 G

Spülhandgriff mit Chopper, 2 seitliche

Spülöffnungen

Irrigation handle with chopper, 2 side

ports

Manche d'irrigation avec nucleus chopper

Mango de irrigación, con chopper

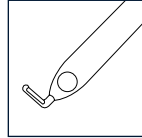

**SA60-1900-55**

ROSEN

19 G

Spülhandgriff mit Kernspalter, 2 seitliche

Spülöffnungen

Irrigation handle with nucleus chopper,

2 side ports

Manche d'irrigation avec chopper

Mango de irrigación, con nucleus chopper



**SA60-1900-75**

ROSEN

19 G

Spülhandgriff mit Kernspalter, Spülöffnung

vorne

Irrigation handle with hydro chopper, end

opening

Manche d'irrigation avec chopper

Mango de irrigación, con nucleus chopper

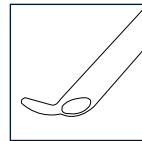

**SA60-1900-81**

NAGAHARA

Spülhandgriff mit Kernspalter, Spülöffnung

vorne

Irrigation handle with hydro chopper, end

opening

Manche d'irrigation avec chopper

Mango de irrigación, con nucleus chopper

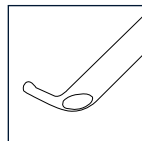

**SA60-1900-83**

NAGAHARA

Spülhandgriff mit Kernspalter 60°,

Spülöffnung vorne

Irrigation handle with hydro chopper

60°, end opening

Manche d'irrigation avec chopper 60°

Mango de irrigación, con nucleus

chopper 60°

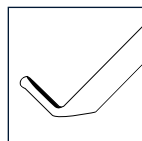

**SA60-1910-00**  
BOWMAN

Disziissionsnadel  
Dicission needle  
Aiguille à dissecion  
Aguja para discisión



**SA60-1913-17**  
WHEELER

Disziissionsnadel  
Discission needle  
Aiguille à dissecion  
Aguja para discisión



**SA60-1914-00**  
JAECKER

Fadenlösmesser  
Knife for suture removal  
Couteau pour couper les fils  
Cuchillo para cortar suturas



**SA60-1915-10**  
KUHNT

Fig. 1  
Hornhautschaber  
Corneal scarifier  
Rugine pour la cornée  
Legra para la cornea



**SA60-1916-20**  
KUHNT

Fig. 2  
Hornhautschaber  
Corneal scarifier  
Rugine pour la cornée  
Legra para la cornea



**SA60-1917-30**  
KUHNT

Fig. 3  
Hornhautschaber  
Corneal scarifier  
Rugine pour la cornée  
Legra para la cornea



**1SA60-918-40**  
KUHNT

Fig. 4  
Hornhautschaber  
Corneal scarifier  
Rugine pour la cornée  
Legra para la cornea



**SA60-1920-45**  
MODELL HEIDELBERG

Raspatorium  
Raspatory  
Rugine  
Legra



**SA60-1925-45**  
MODELL HEIDELBERG

Elevatorium  
Elevator  
Releveur  
Elevador



**SA60-1926-00**  
FREER

Elevatorium doppelendig, scharf/ stumpf  
Periosteal elevator, blunt/ semi-sharp  
Élévateur double, tranchant et mousse  
Elevador y disector



2/3

**IRISMESSER**

**COUTEAUX POUR L'IRIS**

**IRIS KNIVES**

**CUCHILLOS PARA IRIS**

**SA60-1930-45** = 4,5 mm  
**SA60-1930-60** = 6,0 mm  
**SA60-1930-75** = 7,5 mm

**ZIEGLER**

Irismesser  
Iris knife  
Couteau pour l'iris  
Cuchillo para iris



1930-60

**SA60-1932-70**  
KNAPP

Irismesser  
Iris knife  
Couteau pour l'iris  
Cuchillo para iris



**SA60-1945-50**  
WEST

Hohlmeißel für  
Tränensack  
Bone gouge for  
lacrimal sac  
Gouge pour le  
sac lacrymal  
Gubia para el  
saco lacrimal



**SA60-1946-50**  
WEST

Flachmeißel für  
Tränensack  
Bone cisel for  
lacrimal sac  
Ciseau-burin pour  
le sac lacrymal  
Cinzel para el  
saco lacrimal



**SA60-1950-00**  
ROLLET

Meißel für  
Tränensack  
Bone cisel for  
lacrimal sac  
Rugine pour le  
sac lacrymal  
Cinzel para el  
saco lacrimal

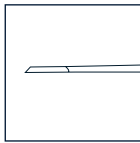

**KYSTOTOME**  
**CYSTOTOMES**

**KYSTOTOMES**  
**QUISTOTOMOS**

**SA60-1958-00**  
GRAEFE

Kystotom, gerade  
Cystotome, straight  
Kystotome, droit  
Quistotomo, derecho

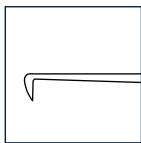

1958-00

**SA60-1960-00**  
GRAEFE

Kystotom, abgewinkelt,  
rechts  
Cystotome, angled, right  
Kystotome, coude á droite  
Quistotomo, angulado  
a la derecha

**SA60-1964-08**  
SCHEPENS

8 mm  
Skleral Depressor  
Scleral Sepsessor  
Dépresseur scléral  
Localizador

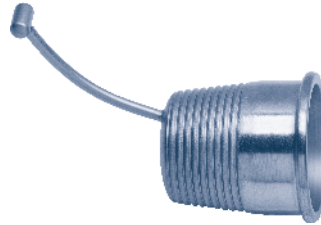

1964-08

**SA60-1964-10**  
SCHEPENS

10 mm  
Skleral Depressor  
Scleral Sepsessor  
Dépresseur scléral  
Localizador

**SA60-1964-12**  
SCHEPENS

12 mm  
Skleral Depressor  
Scleral Sepsessor  
Dépresseur scléral  
Localizador

**SA60-1965-00**  
KREISSIG

Kombideller, doppelendig  
Localizer, double ended  
Localisateur, double  
Localizador, doble

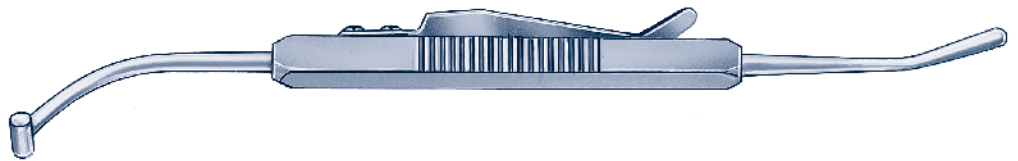

**SA60-1966-00**  
SCHOCKET

Skleral Depressor, doppelendig  
Scleral depressor, double ended  
Dépresseur scléral, double  
Localizador doble



**SA60-1969-00**

CARTER

Einführinstrument  
Introducer for eye spheres  
Introducer  
Introducer

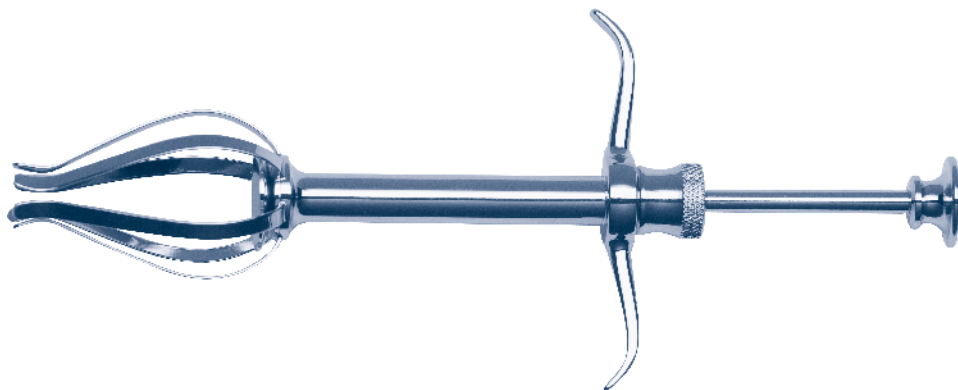

**SA60-1972-00**

KIMURA

Platin Spatel  
Platinum spatula  
Spatule platine  
Espátula, platino



**SA60-1973-12**

BURATTO

Lasik Flap Protektor  
Lasik flap protector  
Lasik flap protecteur  
Lasik flap protector



**SA60-1974-07**

HELVESTON

7 mm

Retraktor, Barbie, Blatt gebogen,  
Retractor, „Barbie“, curved blade  
Ecarteur, „Barbie“, courbe  
Separador, „Barbie“, curvo



**SA60-1974-09**

HELVESTON

9 mm

Retraktor, Big Barbie, Blatt gebogen  
Retractor, „Big Barbie“, curved blade,  
Ecarteur, „Big Barbie“, courbe  
Separador, „Big Barbie“, curvo



**SA60-1974-11**

HELVESTON

11 mm

Retraktor, Great Big Barbie,  
Blatt gebogen  
Retractor, „Great Big Barbie“,  
curved blade  
Ecarteur, „Great Big Barbie“, courbe,  
Separador, „Great Big Barbie“, curvo



**SA60-1975-00**

Keratoplastik Siebpatel, gelocht  
Keratoplasty spatula, perforated  
Spatule pour k eratoplastie, perfor e  
Esp tula para queratoplastia,  
perforada



**SA60-1976-00**  
MODELL GIESSEN

Wundspatel und Retraktor  
Spatula and retractor  
Spatule et ecarteur  
Esp tula y separador



**SA60-1978-30**  
MODELL FRANKFURT

Irisspatel, gebogen  
Iris spatula, curved  
Spatule   iris, courbe  
Esp tula, curva



**SA60-1979-00**  
TROUTMAN

Linsenspatel  
Lens spatula  
Spatule pour la lentille cristalline  
Esp tula para el cristalino



**SA60-1980-05**  
WECKER

0,5 mm  
Irisspatel, sehr fein  
Iris spatula, very delicate  
Spatule pour l'iris, très fine  
Espátula para iris, muy fina



**SA60-1980-01**  
WECKER

1,0 mm  
Irisspatel, fein  
Iris spatula, delicate  
Spatule pour l'iris, fine  
Espátula para iris, fina



**SA60-1980-10**  
WECKER

2,0 mm  
Irisspatel  
Iris spatula  
Spatule pour l'iris  
Espátula para iris



**SA60-1982-10**  
WECKER

2,0 mm  
Irisspatel, Silber 800  
Iris spatula, sterling silver  
Spatule pour l'iris, l'argent  
Espátula para iris, plata



**SA60-1980-20**  
WECKER

3,0 mm  
Irisspatel  
Iris spatula  
Spatule pour l'iris  
Espátula para iris



1983-06

**SA60-1983-06** = 6 mm

**SA60-1983-08** = 8 mm

**SA60-1983-10** = 10 mm

**SA60-1983-12** = 12 mm

**BANGERTER**

Spatel  
Spatula  
Spatule  
Espátula



1983-10



1983-12

**SA60-1984-10** = 1,0 mm  
**SA60-1984-15** = 1,5 mm  
**SA60-984-20** = 2,0 mm

**BANGERTER**  
 Irisspatel  
 Iris spatula  
 Spatule à iris  
 Espátula para iris



**SA60-1985-10**  
**ELSCHNIG**

Cyclodialysespatel  
 Cyclodialysis spatula  
 Spatule pour cyclodialyse  
 Espátula para ciclodialisis



**SA60-1986-10**  
**CASTROVIEJO**

10 mm  
 Cyclodialysespatel  
 Cyclodialysis spatula  
 Spatule pour cyclodialyse  
 Espátula para ciclodialisis



**SA60-1986-15**  
**CASTROVIEJO**

20 mm  
 Cyclodialysespatel  
 Cyclodialysis spatula  
 Spatule pour cyclodialyse  
 Espátula para ciclodialisis



**SA60-11988-00**  
**TROUTMAN**

0,5 mm  
 Micro-Irisspatel  
 Iris spatula for microsurgery  
 Spatule pour microchirurgie  
 Espátula para microcirugía



**SA60-1989-05**

0,5 mm

Phako- und Irisspatel  
Phaco spatula  
Spatule phaco  
Espátula, phaco

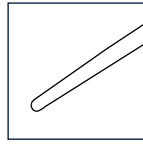

**SA60-1990-01**

KOCH

Irisspatel  
Nucleus spatula, duckbill  
Nucleus spatula  
Nucleus espátula

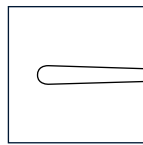

**SA60-1990-02**

KOCH

Irisspatel, mit Einkerbung  
Nucleus spatula, with  
notches  
Nucleus spatule avec  
entaille  
Nucleus espátula con  
muesca

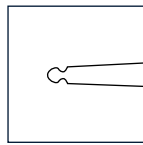

**SA60-1993-05**

BARRAQUER

0,5 mm

Irisspatel, runde Spitze  
Iris spatula, round tip  
Spatule pour l'iris, pointe ronde  
Espátula para iris, punta redonda

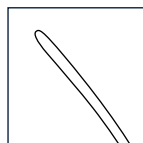

**SA60-1996-13**

1,0 mm

Mikro-Irisspatel, gerade  
Iris spatula for microsurgery, straight  
Spatule pour microchirurgie, droite  
Espátula para microcirugia, recta

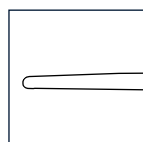

**SA60-2002-00**  
MEYER

Fremdkörper-Hohlmeissel  
Foreign body gouge  
Gouge a corps étrangers  
Gubia para cuerpos extraños



**SA60-2003-00**  
SCHWEIZER MODELL

Fremdkörpernadel  
Foreign body needle  
Instrument a corps étrangers  
Aguja para cuerpos extraños



**SA60-2010-00**

Fremdkörpernadel, gerade  
Foreign body needle, straight  
Aiguille a corps étrangers,  
droite  
Aguja para cuerpos extraños,  
recta

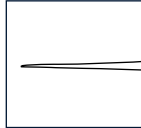

**SA60-2011-00**

Fremdkörpernadel, gebogen  
Foreign body needle, curved  
Aiguille a corps étrangers,  
courbe  
Aguja para cuerpos extraños,  
curva

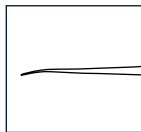

**SA60-12021-00**  
ALVIS

Fremdkörperkürette  
Foreign body spud and curette  
Curette a corps étrangers  
Cucharilla cortante para  
cuerpos extraños

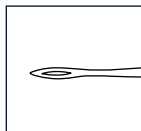

**SA60-2022-00**  
PLANGE

Fremdkörperheber  
Foreign body spud  
Instrument a corps  
étrangers  
Instrumento para cuerpos  
extraños

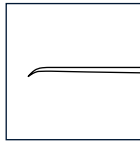

**SA60-2023-00**  
PLANGE

Fremdkörperheber,  
runder Griff  
Foreign body spud,  
round handle  
Instrument a corps  
étrangers, manche rond  
Instrumento para cuerpos  
extraños, mango redondo

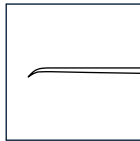

**SA60-2025-00**

Fremdkörperschlinge und  
-magnet  
Foreign body loop and  
magnetic probe  
Anse pour corps étrangers  
et aimant  
Instrumento doble, asa e  
imán para cuerpos extraños



**SA60-2031-00**

DIX

Fremdkörper-Doppelinstrument,  
Flachmeißel-Nadel  
Foreign body instrument, double ended,  
chisel and needle  
Instruments double pour corps étran-  
gers, rugine et aiguille  
Instrumento doble para cuerpos extra-  
ños, cincel y aguja

**SA60-2032-00**

DIX

Fremdkörper-Doppelinstrument,  
Hohlmeißel-Nadel  
Foreign body instrument, double ended,  
gouge and needle  
Instruments double pour corps étran-  
gers, gouge et aiguille  
Instrumento doble para cuerpos extra-  
ños, gubia y aguja

**SA60-2032-10**

DIX

Fremdkörper-Doppelinstrument,  
Hohlmeißel-Nadel, extra fein  
Foreign body instrument, double ended,  
gouge and needle, extremely delicate  
Instruments double pour corps étran-  
gers, gouge et aiguille, extra fine  
Instrumento doble para cuerpos extra-  
ños, gubia y aguja, delicadísima

**SA60-2033-00**

PLANGE

Fremdkörper-Doppelinstrument,  
Fremdkörperhebel-Nadel  
Foreign body instrument, double  
ended, spud and needle  
Instruments double pour corps  
étrangers, manette et aiguille  
Instrumento doble para cuerpos  
extraños, aguja y aguja

**SA60-2036-00**

Fremdkörper-Doppelinstrument,  
Flachmeißel-Nadel  
Foreign body instrument, double  
ended, chisel and needle  
Instruments double pour corps étran-  
gers, rugine et aiguille  
Instrumento doble para cuerpos extra-  
ños, cincel y aguja

**SA60-2037-00**

Fremdkörper-Doppelinstrument,  
Hohlmeißel-Nadel  
Foreign body instrument, double  
ended, gouge and needle  
Instruments double pour corps étran-  
gers, gouge et aiguille  
Instrumento doble para cuerpos extra-  
ños, gubia y aguja



**SA60-2044-00**

Doppelinstrument, Löffel/Spatel  
Double ended instrument, spoon/  
spatula  
Instrument double, spatule et  
curette  
Instrumento doble, cucharilla y  
Espátula



**SA60-2045-00**  
WHEELER

Doppelspatel, leicht gebogen  
Double ended spatula, slightly  
curved  
Spatule double, courbe medium  
Espátula doble, media curva



**SA60-2050-00**  
GREEN

Doppelspatel, leicht gebogen  
Double ended spatula, slightly  
curved  
Spatule double, courbe medium  
Espátula doble, media curva



**SA60-2053-00**  
KIRBY

Linsenschieber und Schlinge  
Lens expressor hook and loop  
Crochet et anse  
Expresor y asa



**SA60-2055-25** (0,25 mm)  
**SA60-2055-50** (0,50 mm)  
CASTROVIEJO

10 & 15 mm  
Doppelspatel  
Double ended spatula  
Spatule double  
Espátula doble



**SA60-2104-10**

DAVIEL

Starlöffel, klein  
Cataract spoon, small  
Curette a cataracte, petite  
Cucharilla para cataratas, pequeña



**SA60-2104-20**

DAVIEL

Starlöffel, groß  
Cataract spoon, large  
Curette a cataracte, grande  
Cucharilla para cataratas, grande



**SA60-2107-10**

HERBA

Chalazionslöffel, klein  
Chalazion curette, small  
Curette a chalazion, petite  
Cucharilla para chalazion, pequeña



**SA60-2107-20**

HERBA

Chalazionslöffel, mittel  
Chalazion curette, medium  
Curette a chalazion, moyenne  
Cucharilla para chalazion, media



**SA60-2107-30**

HERBA

Chalazionslöffel, groß  
Chalazion curette, large  
Curette a chalazion, grande  
Cucharilla para chalazion, grande



MEYHÖFER

**SA60-2108-05** 0,5 mm Ø

**SA60-2108-10** 1,0 mm Ø

**SA60-2108-15** 1,5 mm Ø

**SA60-2108-20** 2,0 mm Ø

**SA60-2108-25** 2,5 mm Ø

**SA60-108-30** 3,0 mm Ø

**SA60-2108-35** 3,5 mm Ø

Chalazionslöffel  
Chalazion curette  
Curette a chalazion  
Cucharilla para chalazion



2108-35

LÖFFEL  
SPOONS

CURETTES  
CUCHARILLAS

**SA60-2111-00**  
WELLS

Enukleationslöffel  
Enucleation spoon  
Levier pour enucléation  
Espátula para enucleación



**SA60-2122-06** 6 mm Ø  
**SA60-2122-08** 8 mm Ø  
**SA60-2122-10** 10 mm Ø  
**SA60-2122-12** 12 mm Ø  
BUNGE

Excenterationslöffel  
Exenteration spoon  
Curette pour exenteration  
Cucharilla para exenteracion



2122-06

SCHLINGEN  
LENS LOOPS

ANSES  
ASAS

**SA60-2150-10**  
WEBER

Schlinge, klein  
Lens loop, small  
Anse, petite  
Asa, pequeña



**SA60-2150-20**  
WEBER

Schlinge, groß  
Lens loop, large  
Anse, grande  
Asa, grande



**SA60-2153-00**  
ARLT

Schlinge, gerieft  
Lens loop, serrated  
Anse, striée  
Asa, estriada



**SA60-2154-00**  
SNELLEN

Schlinge, glatt  
Lens loop, smooth  
Anse, lisse  
Asa, lisa



**SA60-2155-00**  
LEWIS

Schlinge, glatt  
Lens loop, smooth  
Anse, lisse  
Asa, lisa



**2SA60-156-00**  
TROUTMAN

Schlinge, abgewinkelt  
Lens loop, angled  
Anse, coudée  
Asa, angulada



**SA60-2157-00**  
NEW ORLEANS

Schlinge, glatt  
Lens loop, smooth  
Anse, lisse  
Asa, lisa



**SA60-2158-00**  
FLYNN

Sklera-Lokalisator  
Scleral depressor  
Dépresseur scléral  
Localizador



Angabe der 6-stelligen  
Katalognummer genügt.

The indication of the 6-digit  
catalog number is sufficient.

L'indication du numéro de  
catalogue à 6 chiffres suffit.

La indicación del número de  
catálogo de 6 cifras es suficiente.

-04 = Fig. 0000/000  
-03 = 000/00  
-02 = 00/0  
-01 = 0/1  
-12 = 1/2  
-23 = 2/3  
-34 = 3/4  
-45 = 4/5  
-56 = 5/6  
-67 = 6/7  
-78 = 7/8  
-99 = 1 Satz mit 5 oder 6 Stück  
-99 = 1 set with 5 or 6 pieces  
-99 = le jeu de 5 ou 6  
-99 = 1 juego de 5 ó 6 piezas

**BOWMAN**

Tränenkanalsonde, zylindrisch  
Lacrimal probe, cylindrical  
Sonde double pour voices  
lacrimales, cylindrique  
Estilete lacrimal, cilindrico



Neusilber German silver Ruolz Metal blanco	Silber 800 Sterling silver Argent Plata	Edelstahl Stainless steel Acier inoxydable Acero inoxidable
SA60-2180-01	SA60-2181-01 SA60-2181-02	SA60-2182-02
SA60-2180-03 SA60-2180-04 SA60-2180-12	SA60-2181-03 SA60-2181-04 SA60-2181-12	SA60-2182-04 SA60-2182-12
SA60-2180-23 SA60-2180-34 SA60-2180-45	SA60-2181-23 SA60-2181-34 SA60-2181-45	2SA60-182-34
SA60-2180-56 SA60-2180-67 SA60-2180-78	SA60-2181-56 SA60-2181-78	SA60-2182-56

**BOWMAN**

Tränenkanalsonde, geknöpft  
Lacrimal probe, probe tips  
Sonde double pour voices  
lacrimales, olivaire  
Estilete lacrimal, olivar



Neusilber German silver Ruolz Metal blanco	Silber 800 Sterling silver Argent Plata	Edelstahl Stainless steel Acier inoxydable Acero inoxidable
SA60-2184-01 SA60-2184-02 SA60-2184-03 SA60-2184-04	SA60-2185-01 SA60-2185-02	SA60-2186-01 SA60-2186-02
SA60-2184-12 SA60-2184-23 SA60-2184-34 SA60-2184-45	SA60-2185-12 SA60-2185-23 SA60-2185-34 SA60-2185-45	SA60-2186-04 SA60-2186-12 SA60-2186-23 SA60-2186-34 SA60-2186-45
SA60-2184-56 SA60-2184-78	SA60-2185-56 SA60-2185-67 SA60-2185-78	SA60-2186-56 SA60-2186-67 SA60-2186-78

**SA60-2190-10**

**HARMS**

Trabekularsonde, rechts  
 Trabeculotomy probe, right  
 Sonde trabeculótome, droit  
 Estilete trabeculares, derecho

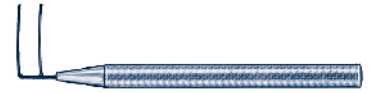

2190-10

**SA60-2190-20**

**HARMS**

Trabekularsonde, links  
 Trabeculotomy probe, left  
 Sonde trabeculótome, gauche  
 Estilete trabeculares, izquierdo

**SA60-2196-60**

**WORST**

Pigtailsonde, mit Haken  
 Pigtail probe, with hook  
 Pigtail stylet lacrymal, avec  
 crochet  
 Pigtail estilete lacrimal, con  
 ganchos



**SA60-2197-00**

**WORST**

Pigtailsonde, mit Öse  
 Pigtail probe, with eye  
 Pigtail stylet lacrymal, avec trou  
 Pigtail estilete lacrimal, con ojete



**SA60-2200-10** Fig. 1  
**SA60-2200-20** Fig. 2  
**SA60-2200-30** Fig. 3  
WILDER (NETTLESHIP)  
4 mm Ø  
Tränenweg-Dilatator  
Lacrimal dilator  
Dilatateur pour voies lacrimales  
Dilatador lacrimal



**SA60-2201-10** Fig. 1  
**SA60-2201-20** Fig. 2  
**SA60-2201-30** Fig. 3  
WILDER  
3 mm Ø  
Tränenweg-Dilatator  
Lacrimal dilator  
Dilatateur pour voies lacrimales  
Dilatador lacrimal

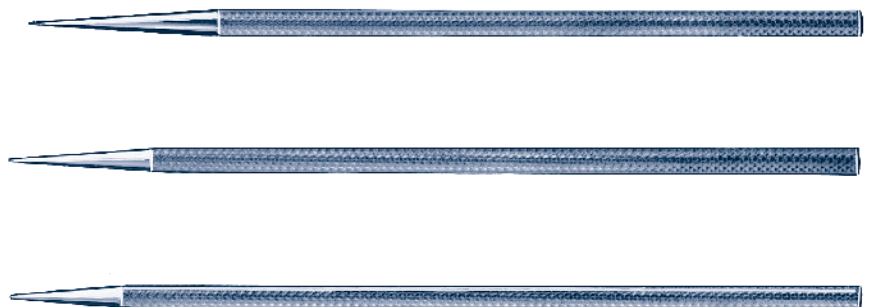

**SA60-2202-00**  
CASTROVIEJO  
Dilatator, doppelendig  
Lacrimal dilator, double ended  
Dilatateur pour voies lacrimales  
double  
Dilatador lacrimal doble



**SA60-2203-00**  
MULDOON  
Dilatator  
Lacrimal dilator  
Dilatateur pour voies lacrimales  
Dilatador lacrimal



**SA60-2206-00**  
RUEDEMANN  
Dilatator für Säuglinge  
Lacrimal dilator for infants  
Dilatateur pour nourrissons  
Dilatador lacrimal para lactantes



**SA60-2207-00**  
MODELL GIESSEN  
Tränenwegsonde, abgewinkelt  
Lacrimal probe, angled  
Sonde a voies lacrymales, coude  
Estilete lacrimal, angulada



## GEFÄSSKLEMMEN

## SERREFINES

## SERRE-FINES

## SERRA-FINAS

### SA60-2260-35 JOHN HOPKINS

3,8 cm

Gefäßklemme, gerade  
Serrefine, straight Serre-  
fine, droit  
Serra-fina, recta



### SA60-2261-35 JOHN HOPKINS

3,8 cm

Gefäßklemme, gebogen  
Serrefine, curved  
Serre-fine, courbe  
Serra-fina, curva



---

## KLEMMEN

## CLAMPS

## PINCES-CLAMPS

## PINZAS-CLAMPS

---

### SA60-2265-95 BACKHAUS

9,5 cm

Tuchklemme  
Towel clamp  
Pince a etoffe  
Pinza de campo

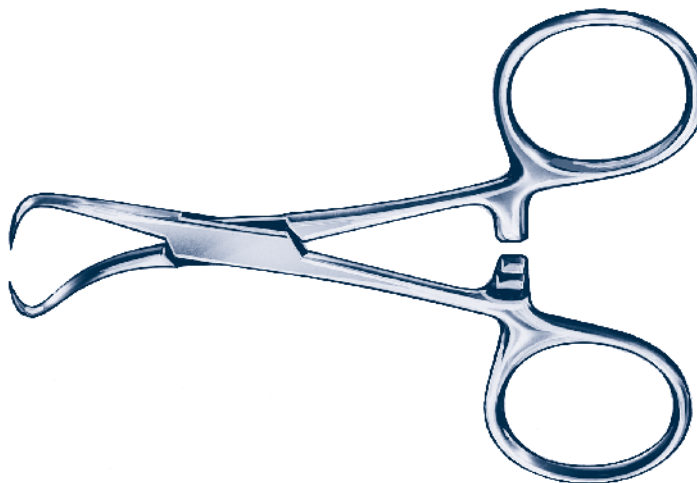

### SA60-2267-50 JONES

Tuchklemme  
Towel clamp, cross action  
Pince a compreses  
Pinza para compresas



**SA60-2272-10**  
HARTMANN-MOSQUITO

10 cm

Arterienklemme, gerade  
Mosquito forceps, straight  
Pince hemostatique, droite  
Pinza hemostatica, recta

**SA60-2273-10**  
HARTMANN-MOSQUITO

10 cm

Arterienklemme, gebogen  
Mosquito forceps, curved  
Pince hemostatique, courbe  
Pinza hemostatica, curva

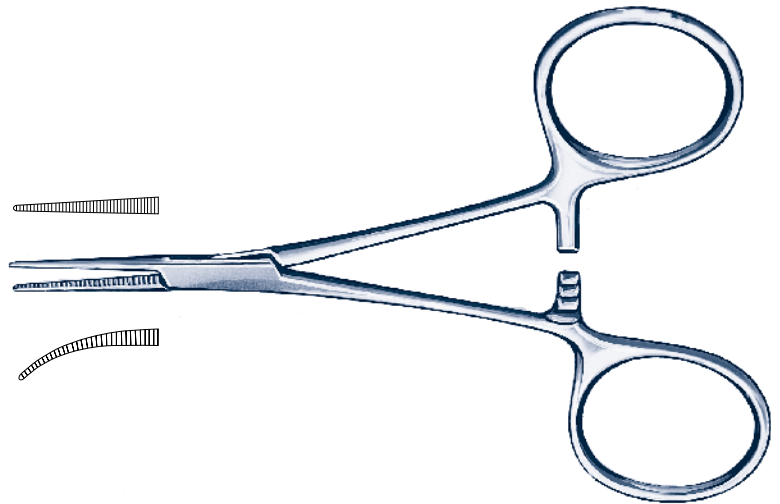

**SA60-2274-12**  
HALSTED-MOSQUITO

12,5 cm

Arterienklemme, gerade  
Mosquito forceps, straight  
Pince hemostatique, droite  
Pinza hemostatica, recta

**SA60-2275-12**  
HALSTED-MOSQUITO

12,5 cm

Arterienklemme, gebogen  
Mosquito forceps, curved  
Pince hemostatique, courbe  
Pinza hemostatica, curva

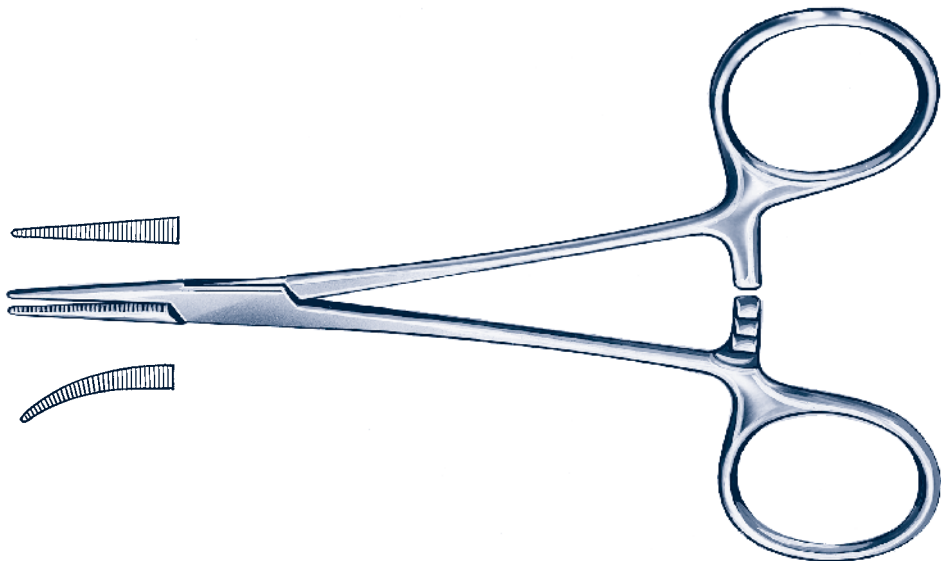

**SA60-2285-15**

GASS

1,5 mm

Sklerotomie Stanze  
Sclerotomy punch  
Emporte-pièce  
Punzón

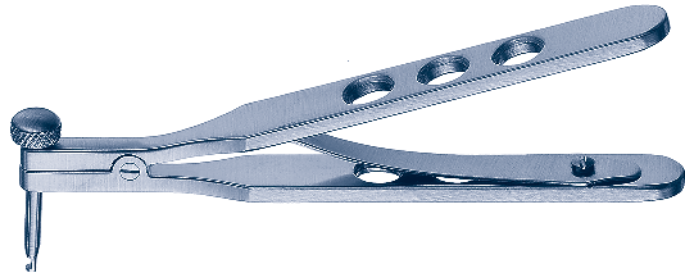
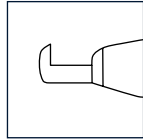

**SA60-2286-10**

KELLY

1,0 mm

Descement Membran Stanze  
Descement's membrane punch  
Emporte-pièce  
Punzón

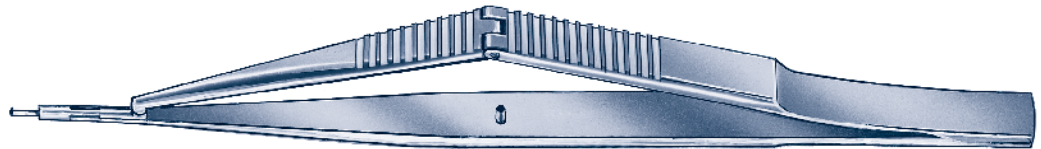
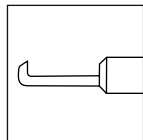

**SA60-2288-10** 1,0 mm

**SA60-2288-15** 1,5 mm

HOLTH

Kapselstanze  
Corneoscleral punch  
Emporte-pièce capsulaire  
Punzón capsular

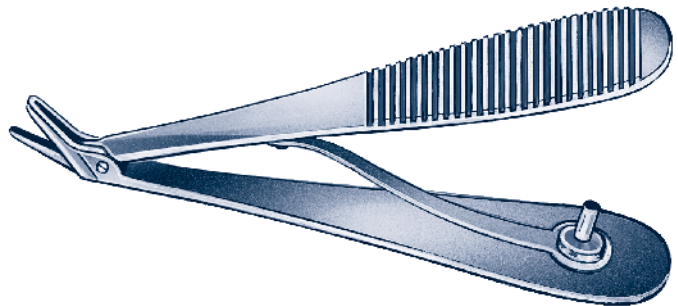

**SA60-2290-10**

LUNTZ-DODICK

1,0 mm

Trabekulektomie Stanze  
Trabeculectomy punch  
Punch trabeculectomie  
Punzón para trabeculectomía

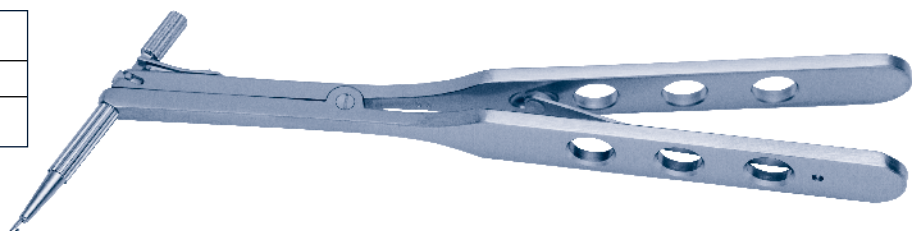
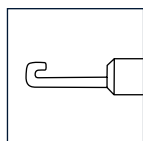

**SA60-2293-30** 3,0 mm  
**SA60-2294-40** 4,0 mm  
KERRISON  
Knochenstanze  
Rongeur  
Emporte-pièce  
Pinza-gubia

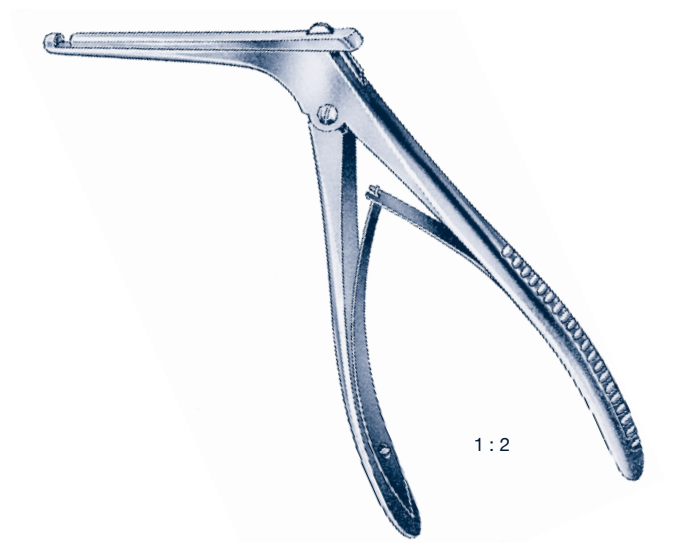

**2SA60-296-20** 2,0 mm  
**SA60-2296-30** 3,0 mm  
CITELLI  
Knochenstanze  
Rongeur  
Emporte-pièce  
Pinza-gubia

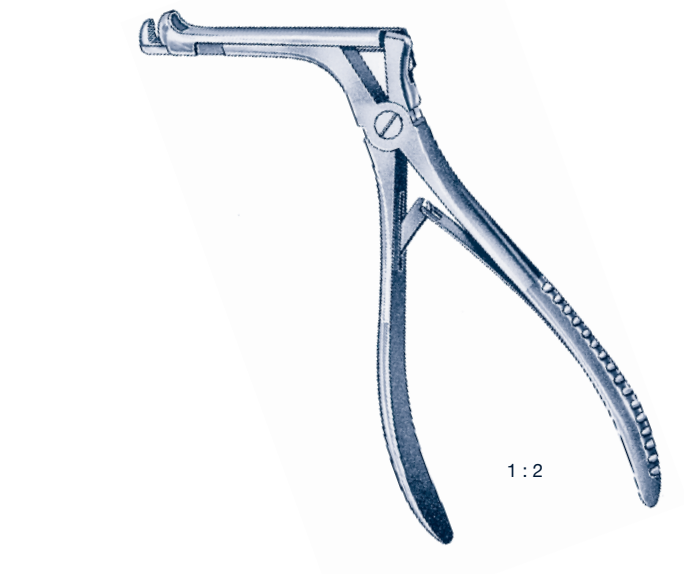

**SA60-2298-20**  
BEYER  
2,0 mm  
Knochenstanze  
Rongeur  
Emporte-pièce  
Pinza-gubia

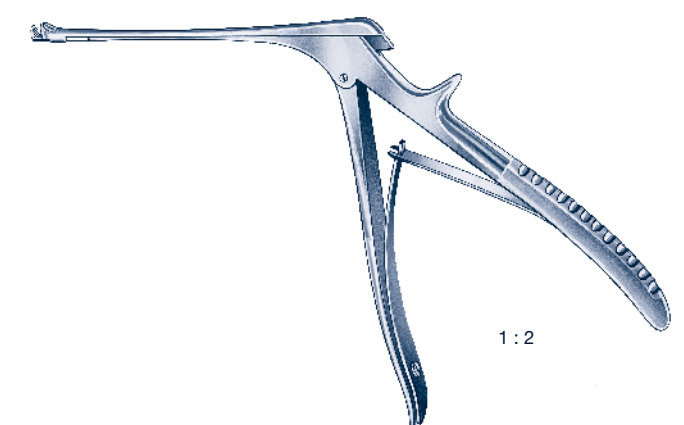

- SA60-2312-10** 1,0 mm
  - SA60-2312-12** 1,2 mm
  - SA60-2312-15** 1,5 mm
  - SA60-2312-17** 1,7 mm
- SCHWEIZER MODELL

Hornhauttrephine  
Corneal trephine  
Trepan cornéen  
Trepano corneal

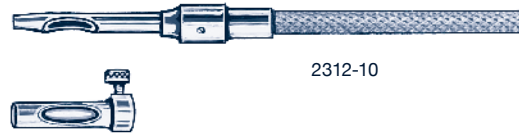

**SA60-2319-00**

Handgriff für Hornhauttrephinen  
Handle for corneal trephines  
Manche pour trepans  
Mango para trepanos corneal

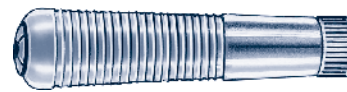

- SA60-2328-50** 5,0 mm
- SA60-2328-55** 5,5 mm
- SA60-2328-60** 6,0 mm
- SA60-2328-65** 6,5 mm
- SA60-2328-70** 7,0 mm
- SA60-2328-75** 7,5 mm
- SA60-2328-80** 8,0 mm
- SA60-2328-85** 8,5 mm
- SA60-2328-90** 9,0 mm
- SA60-2329-10** 10,0 mm
- SA60-2329-11** 11,0 mm

CASTROVIEJO

Hornhauttrephine  
Corneal trephine  
Trepan cornéen  
Trepano corneal

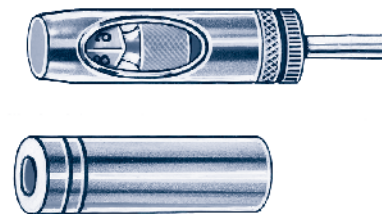

**SA60-2367-20**  
CASTROVIEJO-SCHACHAR

Zirkel, gebogen  
Caliper, curved  
Compas, courbe  
Compas, curvo

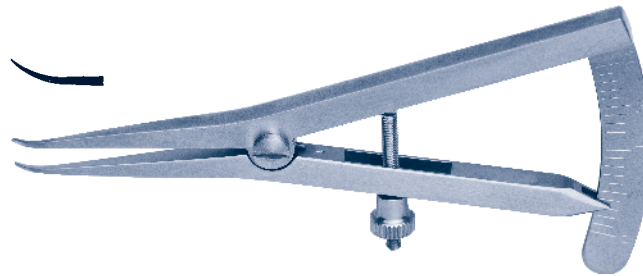

**SA60-2369-15**  
CASTROVIEJO

Zirkel, gerade  
Caliper, straight  
Compas, droite  
Compas, recto

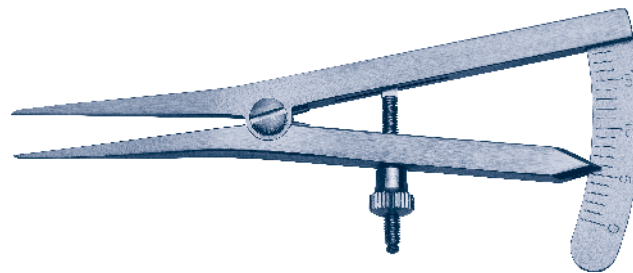

**SA60-2370-20**  
CASTROVIEJO

Zirkel, gerade  
Caliper, straight  
Compas, droite  
Compas, recto

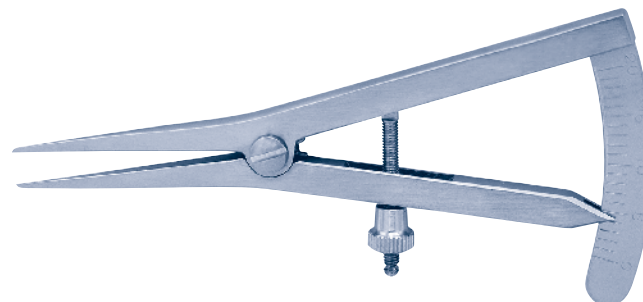

**SA60-2371-30**  
GIESSEN



**SA60-2375-00**  
MEYER-SCHWICKERATH

Lokalisator und Skleraldepressor  
Localizer and scleral depressor  
Pique à fixation et dépresseur  
Punto de fijación y depresor



**SA60-2376-18**  
O'CONNOR

Skleral Depressor und Skleral  
Markierer, doppelendig  
Scleral depressor and scleral  
marker, double ended  
Épresseur scléral et marqueur,  
double  
Localizador y marcador, doble



- SA60-2382-30** = 3,0 mm Ø
- SA60-2382-35** = 3,5 mm Ø
- SA60-2382-40** = 4,0 mm Ø
- SA60-2382-50** = 5,0 mm Ø
- SA60-2382-60** = 6,0 mm Ø
- SA60-2382-70** = 7,0 mm Ø

**HOFFER**

Hornhautmarkierer für optisches Zentrum, mit Fadenkreuz  
Corneal marker for optic zone, with cross hairs  
Marqueur pour centre optique, avec croix de centrage  
Marcador para centro optico, con retículo



SA60-2382-30

- SA60-2383-30** = 3,0 mm Ø
- SA60-2383-40** = 4,0 mm Ø
- SA60-2383-80** = 8,0 mm Ø

**THORNTON**

Hornhautmarkierer für optisches Zentrum, mit Zentrierstift  
Corneal marker for optic zone, with centering pin  
Marqueur pour centre optique  
Marcador para centro optico



SA60-2383-40

- SA60-2384-30** = 3,0 mm Ø
- SA60-2384-35** = 3,5 mm Ø
- SA60-2384-40** = 4,0 mm Ø
- SA60-2384-50** = 5,0 mm Ø
- SA60-2384-55** = 5,5 mm Ø
- SA60-2384-65** = 6,5 mm Ø
- SA60-2384-70** = 7,0 mm Ø

**BORES**

Hornhautmarkierer für optisches Zentrum  
Corneal marker for optic zone  
Marqueur pour centre optique  
Marcador para centro optico



SA60-2384-35

- SA60-2385-04** = 4 Klängen / lines / lames / hojas
- SA60-2385-06** = 6 Klängen / lines / lames / hojas
- SA60-2385-08** = 8 Klängen / lines / lames / hojas
- SA60-2385-12** = 12 Klängen / lines / lames / hojas
- SA60-2385-16** = 16 Klängen / lines / lames / hojas

**OSHER-NEUMANN**

Hornhautmarkierer  
Corneal marker  
Marqueur pour la cornee  
Marcador corneal



SA60-2385-06

**SA60-2393-17**  
**THORNTON**

17 mm Ø

Fixierring, 12 Zähne  
Globe fixation ring, 12 teeth  
Anneau de fixation, 12 griffes  
Anillo de fijación, 12 dientes



**SA60-2394-13**  
**NEUHANN**

13 mm Ø

Fixierring für clear cornea, vorne offen,  
6 Zähne  
Fixation ring for clear cornea, open  
front, 6 teeth  
Anneau de fixation, 6 griffes  
Anillo de fijación, 6 dientes



**SA60-2395-13** = 13 mm Ø  
**SA60-2395-16** = 16 mm Ø  
**FINE-THORTON**

Fixierring für clear cornea, Ring vorne  
offen und beweglich, 10 Zähne  
Fixation ring for clear cornea, open  
front, swivel ring, 10 teeth  
Anneau de fixation, 10 griffes  
Anillo de fijación, 10 dientes



- SA60-2398-14** = 14 mm Ø
  - SA60-2398-15** = 15 mm Ø
  - SA60-2398-16** = 16 mm Ø
  - SA60-2398-17** = 17 mm Ø
  - SA60-2398-18** = 18 mm Ø
  - SA60-2398-19** = 19 mm Ø
  - SA60-2398-20** = 20 mm Ø
  - SA60-2398-21** = 21 mm Ø
- FLIERINGA**

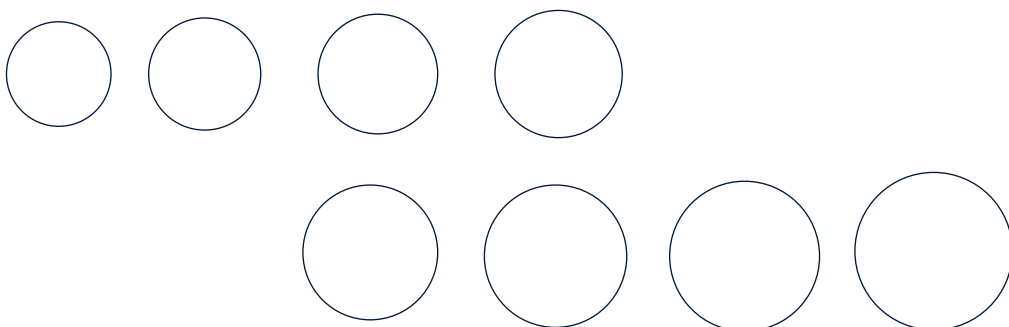

Fixierring  
Fixation ring  
Anneau de fixation Anillo de fijación

**CHIRURGISCHE PINZETTEN**

**TISSUE FORCEPS**

- SA60-2400-05** = 0,5 mm
- SA60-2400-07** = 0,7 mm
- SA60-2400-10** = 1,0 mm
- SA60-2400-12** = 1,2 mm
- SA60-2400-14** = 1,4 mm

Irispinzette, gerade, 1x2 Zähne  
 Iris forceps, straight, 1x2 teeth  
 Pince à iris, droite, 1x2 griffes  
 Pinza para iris, recta, 1x2 dientes

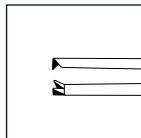

**PINCE CHIRURGICALE**

**PINZAS PARA TEJIDO**

- SA60-2401-07** = 0,7 mm
- SA60-2401-10** = 1,0 mm

Irispinzette, schwach gebogen, 1x2 Zähne  
 Iris forceps, slightly curved, 1x2 teeth  
 Pince à iris, courbe, 1x2 griffes  
 Pinza para iris, curva suave, 1x2 dientes

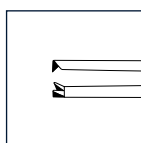

- SA60-2403-07** = 0,7 mm

Irispinzette, stark gebogen, 1x2 Zähne  
 Iris forceps, strong curved, 1x2 teeth  
 Pince à iris, courbe, 1x2 griffes  
 Pinza para iris, muy curva, 1x2 dientes

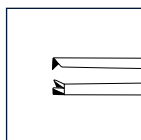

**ANATOMISCHE PINZETTEN**

**DRESSING FORCEPS**

- SA60-2410-05** = 0,5 mm
- SA60-2410-07** = 0,7 mm
- SA60-2410-10** = 1,0 mm
- SA60-2410-12** = 1,2 mm

Irispinzette, gerade, mit Querriefen  
 Iris forceps, dressing, straight  
 Pince à iris, striée, droite  
 Pinza para iris, estriada, recta

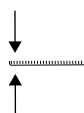
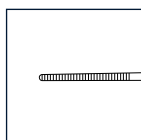

2410-05

- SA60-2411-05** = 0,5 mm
- SA60-2411-07** = 0,7 mm

Irispinzette, schwach gebogen, mit Querriefen  
 Iris forceps, dressing, slightly curved  
 Pince à iris, striée, courbe  
 Pinza para iris, estriada, curva suave

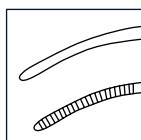

2411-07

- SA60-2413-07** = 0,7 mm

Irispinzette, stark gebogen, mit Querriefen  
 Iris forceps, dressing, strong curved  
 Pince à iris, striée, courbe  
 Pinza para iris, estriada, muy curva

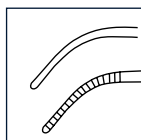

**SA60-2420-10** = 1,2 mm  
ADSON

Chirurgische Pinzette, 1 x 2 Zähne  
Tissue forceps, 1 x 2 teeth  
Pince chirurgicale, 1 x 2 griffes  
Pinza para tejido, 1 x 2 dientes

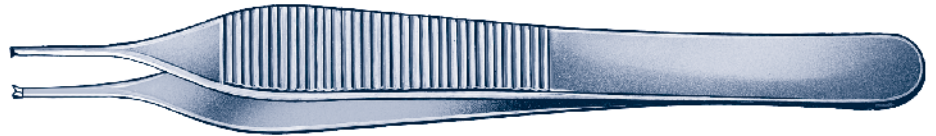
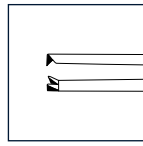

**SA60-2422-10** = 1,1 mm  
ADSON

Anatomische Pinzette, gerieft  
Dressing forceps, serrated  
Pince anatomique, striée  
Pinza para vendajes, estriada

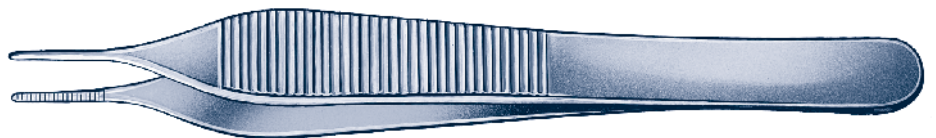
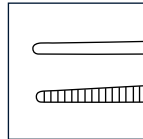

**PINZETTEN FÜR MIKRO-CHIRURGIE**

**FORCEPS FOR MICRO-SURGERY**

**PINCES À MICRO-CHIRURGIE**

**PINZAS PARA MICRO-CIRUGIA**

**SA60-2425-00**  
ELZE

Irispinzette, 1 x 2 Zähne, sehr fein  
Iris forceps, 1 x 2 teeth, very delicate  
Pince à iris, 1 x 2 griffes, extra fine  
Pinza para iris, 1 x 2 dientes, delicadísimo

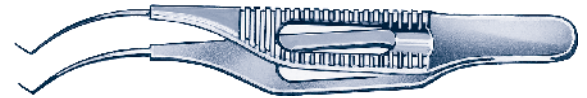
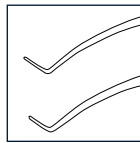

**SA60-2426-03**  
TENNANT

Fadenpinzette, gerade, 6 mm Fadenplatte  
Tying forceps, straight, 6 mm tying platform  
Pince à fils, droite, 6 mm plateaux  
Pinza para anudar, recta, plataforma de 6 mm



2427-03

**SA60-2427-03**  
TENNANT

Fadenpinzette, gebogen, 6 mm Fadenplatte  
Tying forceps, curved, 6 mm tying platform  
Pince à fils, courbe, 6 mm plateaux  
Pinza para anudar, curva, plataforma de 6 mm

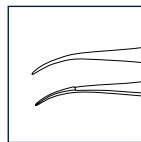

**SA60-2428-01**  
CASTROVIEJO-WARING

Fixierpinzette, 1 x 2 Zähne, Fadenplatte  
Fixation forceps, 1 x 2 teeth, tying platform  
Pince à fixer, 1 x 2 griffes, plateaux  
Pinza de fijacion, 1 x 2 dientes, plataforma

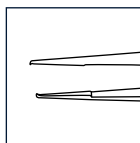

**SA60-2430-02**  
DERMOT-PIERSE

Ø 0,2 mm  
1 x 1 Zähne  
1 x 1 teeth  
1 x 1 griffes  
1 x 1 dientes

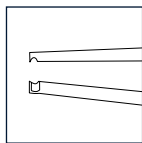

**SA60-2432-00**  
REMKY

2 Zinken mit 1 x 2 Zähnen, abgewinkelt  
2 prongs with 1 x 2 teeth, angled  
2 griffes avec 1 x 2 griffes, angulaire  
2 puas con 1 x 2 dientes, angulado

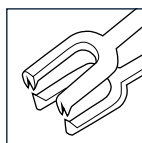

**SA60-2433-12** = 0,12 mm  
BONNER MODELL

Nahtpinzette, gerade,  
1 x 2 Zähne, Fadenplatte  
Suture Forceps, straight,  
1 x 2 teeth, tying platform  
Pince pour sutures, droite,  
1 x 2 griffes, plateaux  
Pinza de diseccion, recta,  
1 x 2 dientes, plataforma

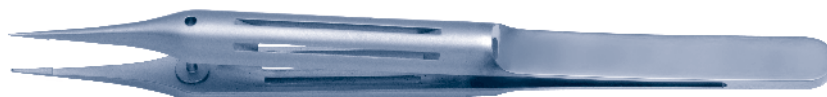
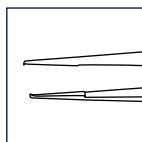

**SA60-2434-12** = 0,12 mm  
**SA60-2434-30** = 0,30 mm  
**SA60-2434-50** = 0,50 mm  
BONNER MODELL

gerade, 1 x 2 Zähne, Fadenplatte  
straight, 1 x 2 teeth, platform  
droite, 1 x 2 griffes, plateaux  
recta, 1 x 2 dientes, plataforma

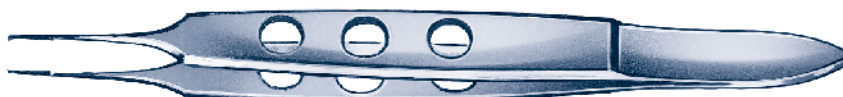

**SA60-2436-12** = 0,12 mm  
BONNER MODELL

gerade, 1 x 2 Zähne, Fadenplatte  
straight, 1 x 2 teeth, platform  
droite, 1 x 2 griffes, plateaux  
recta, 1 x 2 dientes, plataforma

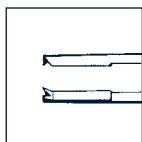

**SA60-2438-12** = 0,12 mm  
BONNER MODELL

gerade, 1 x 2 Zähne, Fadenplatte  
straight, 1 x 2 teeth, platform  
droite, 1 x 2 griffes, plateaux  
recta, 1 x 2 dientes, plataforma

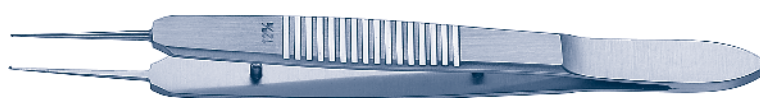
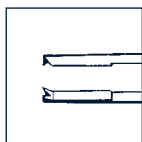

**SA60-2439-12** = 0,12 mm  
**BONN**

gerade, 1 x 2 Zähne, ohne Fadenplatte  
 straight, 1 x 2 teeth, without platform  
 droite, 1 x 2 griffes, sans plateaux  
 recta, 1 x 2 dientes, sin plataforma



**SA60-2440-30** = 0,3 mm  
**McPHERSON**

gerade, 1 x 2 Zähne, Fadenplatte  
 straight, 1 x 2 teeth, platform  
 droite, 1 x 2 griffes, plateaux  
 recta, 1 x 2 dientes, plataforma

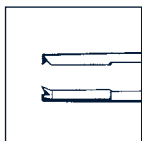

**SA60-2441-30** = 0,3 mm  
**McPHERSON**

abgewinkelt, 1 x 2 Zähne, Fadenplatte  
 angled, 1 x 2 teeth, platform  
 coudée, 1 x 2 griffes, plateaux  
 angulada, 1 x 2 dientes, plataforma

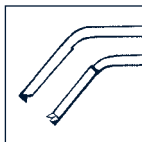

**SA60-2442-01**  
**BONN MCPHERSON**

gerade, Fadenplatte  
 straight, tying platform  
 droite, plateaux  
 recto, plataforma

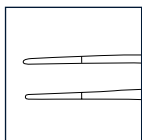

**SA60-2443-01**  
**BONN MCPHERSON**

gebogen, Fadenplatte  
 curved, tying platform  
 courbe, plateaux  
 curva, plataforma

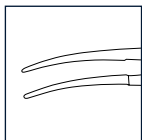

**SA60-2442-50** = 0,5 mm  
**McPHERSON**

gerade, ohne Zähne, Fadenplatte  
 straight, without teeth, tying platform  
 droite, sans griffes, plateaux  
 recta, sin dientes, plataforma

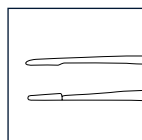

**SA60-2443-50** = 0,5 mm  
**McPHERSON**

abgewinkelt, ohne Zähne, Fadenplatte  
 angled, without teeth, tying platform  
 coudée, sans griffes, plateaux  
 angulada, sin dientes, plataforma

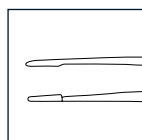

**PINZETTEN FÜR MIKRO-CHIRURGIE**  
**FORCEPS FOR MICRO-SURGERY**

**PINCES À MICRO-CHIRURGIE**  
**PINZAS PARA MICRO-CIRUGIA**

**SA60-2444-06** = 6 mm  
**SA60-2444-08** = 8 mm  
**BONN**

gerieft, abgewinkelt, ohne Zähne  
 serrated, angled, without teeth  
 striée, coudée, sans griffes  
 estriada, angulada, sin dientes

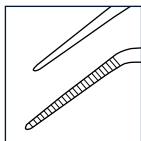

2444-06

**SA60-2445-12** = 0,12 mm  
**BONN**

gerade, 1 x 2 Zähne, Fadenplatte  
 straight, 1 x 2 teeth, tying platform  
 droite, 1 x 2 griffes, plateaux  
 recta, 1 x 2 dientes, plataforma

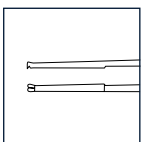

**SA60-2446-12** = 0,12 mm  
**BONN**

abgewinkelt, 1 x 2 Zähne,  
 ohne Fadenplatte  
 angled, 1 x 2 teeth, without tying  
 platform  
 coudée, 1 x 2 griffes, sans plateaux  
 angulada, 1 x 2 dientes, sin plataforma

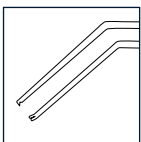

**SA60-2447-12** = 0,12 mm  
**BONN**

abgewinkelt, 1 x 2 Zähne, Fadenplatte  
 angled, 1 x 2 teeth, tying platform  
 coudée, 1 x 2 griffes, plateaux  
 angulada, 1 x 2 dientes, plataforma

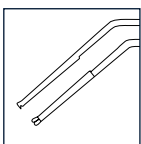

**SA60-2448-00** = 0,3 mm  
**BONN**

gerade, ohne Zähne, Fadenplatte  
 straight, without teeth, tying platform  
 droite, sans griffes, plateaux  
 recta, sin dientes, plataforma

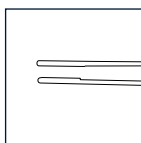

**SA60-2448-12** = 0,12 mm

**SA60-448-20** = 0,20 mm  
**BONN**

gerade, 1 x 2 Zähne, Fadenplatte  
 straight, 1 x 2 teeth, tying platform  
 droite, 1 x 2 griffes, plateaux  
 recta, 1 x 2 dientes, plataforma

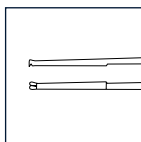

2448-12

**SA60-2449-12** = 0,12 mm

**SA60-2449-20** = 0,20 mm  
**BONN**

gerade, 1 x 2 Zähne, ohne Fadenplatte  
 straight, 1 x 2 teeth, without tying platform  
 droite, 1 x 2 griffes, sans plateaux  
 recta, 1 x 2 dientes, sin plataforma

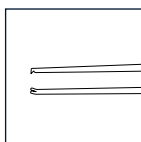

2449-12

**SA60-2678-12**  
**BONN**

gerade, 1 x 2 Zähne, Fadenplatte  
 straight, 1 x 2 teeth, tying platform  
 droite, 1 x 2 griffes, plateaux  
 recta, 1 x 2 dientes, plataforma

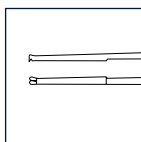

**SA60-2450-05** = 0,5 mm

**SA60-2450-07** = 0,7 mm

gerade, 1 x 2 Zähne, ohne Fadenplatte  
 straight, 1 x 2 teeth, without tying platform  
 droite, 1 x 2 griffes, sans plateaux  
 recta, 1 x 2 dientes, sin plataforma

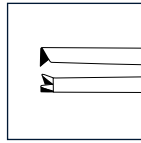

**SA60-2451-05** = 0,5 mm

HEIDELBERG

leicht gebogen, 1 x 2 Zähne, ohne Fadenplatte  
 slightly curved, 1 x 2 teeth, without tying platform  
 demi-courbée, 1 x 2 griffes, sans plateaux  
 curva suave, 1 x 2 dientes, sin plataforma

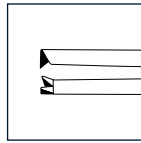

**SA60-2457-05** = 0,5 mm

HEIDELBERG

stark gebogen, 1 x 2 Zähne, ohne Fadenplatte  
 strong curved, 1 x 2 teeth, without tying platform  
 très courbée, 1 x 2 griffes, sans plateaux  
 muy curva, 1 x 2 dientes, sin plataforma

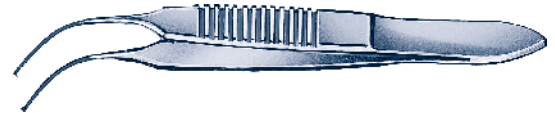
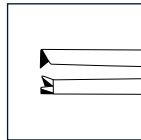

**SA60-2451-07** = 0,7 mm

gebogen, 1 x 2 Zähne, ohne Fadenplatte  
 curved, 1 x 2 teeth, without tying platform  
 courbée, 1 x 2 griffes, sans plateaux  
 curva, 1 x 2 dientes, sin plataforma

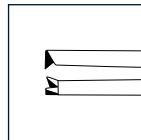

**SA60-2452-07** = 0,7 mm

gerade, gerieft straight,  
 serrated droite, striée  
 recta, estriada

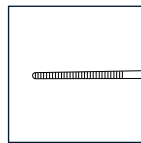

**SA60-2453-07** = 0,7 mm

gebogen, gerieft curved,  
 serrated courbe, striée curva,  
 estriada

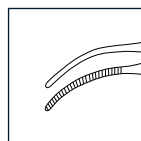

**SA60-2454-00** = 0,8 mm

**SA60-2454-50** = 0,5 mm

**BISHOP-HARMON**

gerade, 1 x 2 Zähne, ohne Fadenplatte  
 straight, 1 x 2 teeth, without tying platform  
 droite, 1 x 2 griffes, sans plateaux  
 recta, 1 x 2 dientes, sin plataforma

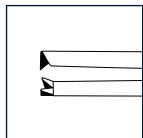

2454-00

**SA60-2454-05** = 0,5 mm

**SA60-2454-07** = 0,7 mm

**BISHOP-HARMON**

gerade, gerieft  
 straight, serrated  
 droite, striée  
 recta, estriada

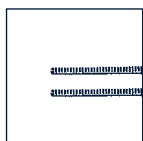

**SA60-2456-00** = 0,8 mm

**LESTER**

gerade, 1 x 2 Zähne, ohne Fadenplatte  
 straight, 1 x 2 teeth, without tying platform  
 droite, 1 x 2 griffes, sans plateaux  
 recta, 1 x 2 dientes, sin plataforma

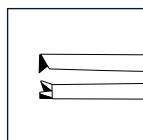

**SA60-2458-00** = 0,35 mm

**HAMBURG**

gerade, 1 x 2 Zähne, ohne Fadenplatte  
 straight, 1 x 2 teeth, without tying platform  
 droite, 1 x 2 griffes, sans plateaux  
 recta, 1 x 2 dientes, sin plataforma

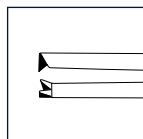

**SA60-2465-00**

**HESS**

Standard Modell, 1 x 2 Zähne  
 standard model, 1 x 2 teeth  
 modèle classique, 1 x 2 griffes  
 modelo clásico, 1 x 2 dientes

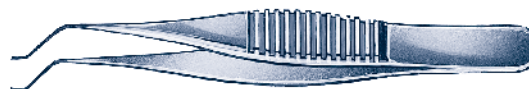
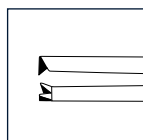

**SA60-2466-10**

**UTRATA**

11 mm abgewinkelt, feine Spitzen  
 11 mm angled shanks, delicate tips  
 branches 11 mm coudée, pointes délicates  
 11 mm angulada, puntas fiñas

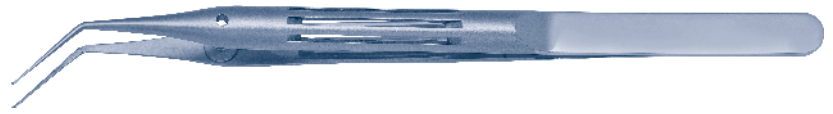
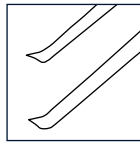

**SA60-2466-20**

**GIANETTI**

geschweift, feine Spitzen, 2,2 mm Inzision  
 vaulted shanks, fine tips, 2,2 mm incision  
 branches courbées, pointes délicates,  
 2,2 mm incision  
 curva, muy fina, para incisión de 2,2 mm



**SA60-2468-00**

**INAMURA**

gekreuzt, kurzes Modell  
 cross action, short model  
 croisée, modèle courte  
 cruzada, modelo corto

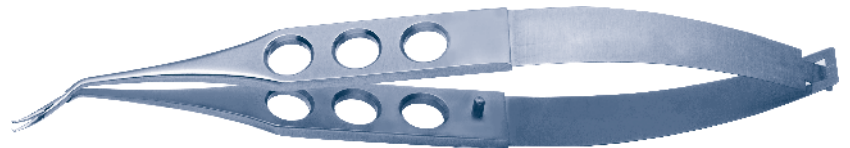

**SA60-2469-00**

**MASKET**

geschweift, 11 mm lange Schenkel  
 11 mm vaulted shanks  
 branches courbées, 11 mm  
 curva, lados de un largo de 11 mm



**SA60-2469-01**

UTRATA

abgewinkelt, 12 mm lange Schenkel  
 angled, 12 mm shanks  
 branches coudées, 12 mm  
 agulada, lados de un largo de 12 mm

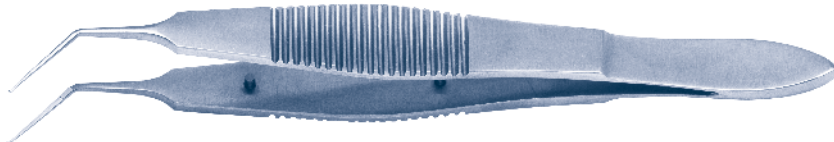
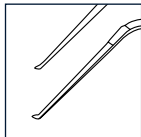

**SA60-2470-12**

UTRATA

abgewinkelt, 12 mm lange Schenkel  
 angled, 12 mm shanks  
 branches coudées, 12 mm  
 agulada, lados de un largo de 12 mm

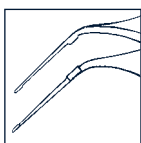

**SA60-2471-00**

UTRATA

abgewinkelt, 11 mm lange Schenkel  
 angled, 11 mm shanks  
 branches coudées, 11 mm  
 agulada, lados de un largo de 11 mm

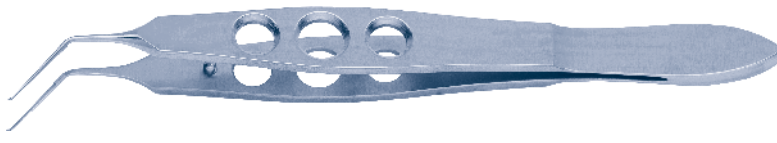
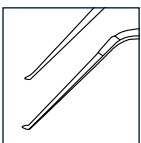

**SA60-2471-05**

UTRATA

sehr fein  
 extremely delicate  
 très fine  
 muy fina



**SA60-2471-10**

UTRATA

abgewinkelt, runde Spitzen  
 angled, rounded tips  
 coudée, extrémité mousse  
 agulada, puntas redondas

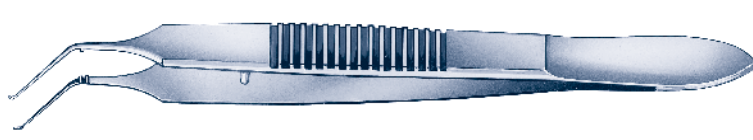
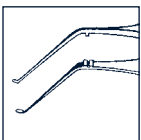

**SA60-2471-12**

KRAFF-UTRATA

1,8 mm Inzision  
 geschweift, 12 mm lange Schenkel  
 12 mm vaulted shanks  
 branches courbées, 12 mm  
 curva, lados de un largo de 12 mm

**SA60-2472-00****MASKET**

1,8 mm Inzision  
 geschweift, 12 mm lange Schenkel  
 12 mm vaulted shanks  
 branches courbées, 12 mm  
 curva, lados de un largo de 12 mm

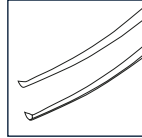
**SA60-2473-00****UTRATA**

1,8 mm Inzision  
 abgewinkelt, 12 mm lange Schenkel  
 angled, 12 mm shanks  
 branches coudées, 12 mm  
 angulada, lados de un largo de 12 mm

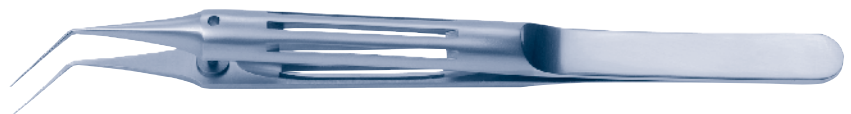
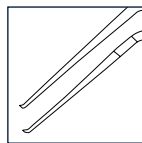
**SA60-2474-00****CORYDON**

1,8 mm Inzision  
 geschweift, 11 mm lange Schenkel,  
 geriefte Spitzen  
 11 mm vaulted shanks, serrated tips  
 branches courbées, 11 mm, mors stries  
 curva, lados de un largo de 11 mm,  
 puntas estriada

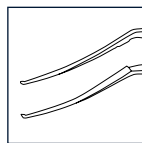
**SA60-2479-00****INAMURA**

1,4 mm Inzision  
 gekreuzt, kurzes Modell  
 cross action, short model  
 croisée, modèle courte  
 cruzada, modelo corto

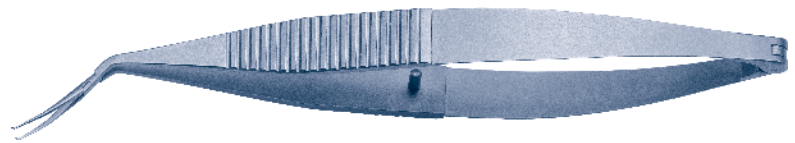
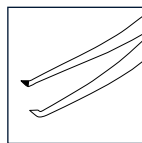

**SA60-2480-00**

BURATTO

IOL Pinzette für gefaltete Linsen  
 IOL forceps, cross action  
 Pince pour IOL  
 Pinza para IOL



**SA60-2481-00**

BURATTO

IOL Pinzette für gefaltete Linsen  
 IOL forceps, cross action  
 Pince pour IOL  
 Pinza para IOL

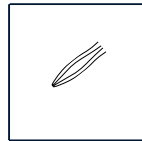

**SA60-2482-12**

SPALECK

Linsenimplantationspinzette, sehr fein,  
 konkave Maulteile  
 Soft IOL inserting forceps, convex jaws  
 Pince pour IOL, convexe  
 Pinza para IOL, convexa

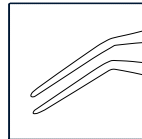

**2483-06**

LIVERNOIS

Linsenhaltepinzette, abgewinkelt,  
 runde Maulteile  
 Lens holding forceps, angled, round,  
 smooth jaws  
 Pince pour IOL, coudée,  
 mors ronds polis  
 Pinza para lentes, angulada, puntas  
 redondas

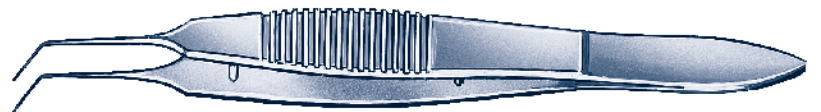
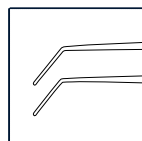

**SA60-2485-00**

BURATTO

IOL Pinzette für gefaltete Linsen  
 IOL forceps  
 Pince pour IO  
 Pinza para IOL



**SA60-2486-00**

**MCDONALD II**

IOL Pinzette für gefaltete Linsen  
 IOL forceps  
 Pince pour IOL  
 Pinza para IOL



**SA60-2487-00**

**LIVERNOIS**

Aufnahme- und Faltpinzette  
 Lens holding and folding forceps  
 Pince pour saisir et plier l'implant  
 Pinza para tomar y plegar



**SA60-2488-00**

**GASKIN**

Fragmentpinzette  
 Fragment forceps  
 Pince à fragments  
 Pinza de fragmento

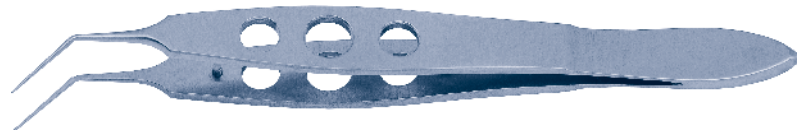
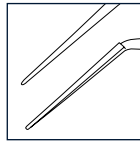

**SA60-2488-60**

**BURATTO**

IOL Pinzette für gefaltete Linsen  
 IOL forceps  
 Pince pour IOL  
 Pinza para IOL

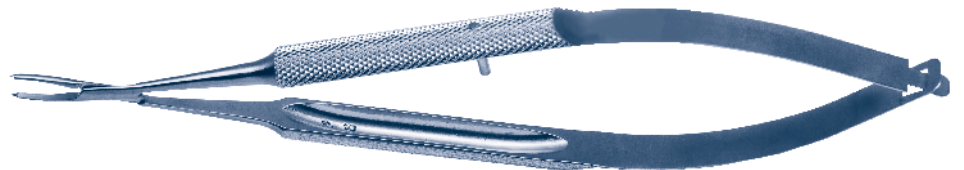

**SA60-2489-00**

**KANSAS**

Fragmentpinzette, 2 Reihen Zähne  
 Fragment forceps, two rows of teeth  
 Pince à fragments, avec griffes  
 Pinza de fragmento, avec dientes

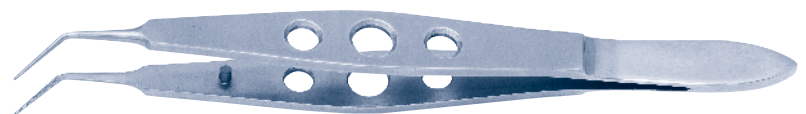
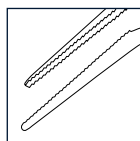

**SA60-2490-00**  
CLAYMAN

Linsenimplantationspinzette  
Soft IOL inserting forceps  
Pince pour IOL  
Pinza para IOL

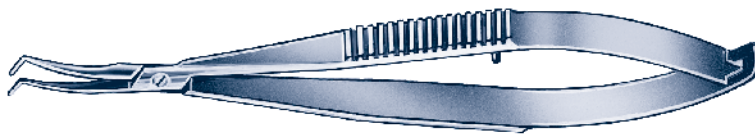
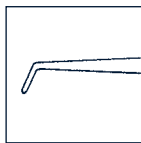
**SA60-2491-00**  
DODEN

Linsenimplantationspinzette  
Soft IOL inserting forceps  
Pince pour IOL  
Pinza para IOL

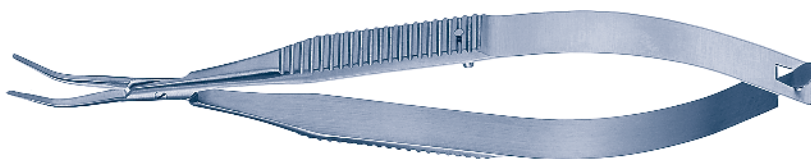
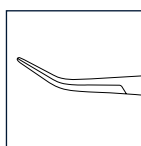
**SA60-2493-80**  
SHEPARD

Linsenimplantationspinzette, mit  
Stop  
Soft IOL inserting forceps, with stop  
Pince pour IOL, avec arrêt fermeture  
et verrou  
Pinza para IOL, con tope y cierre

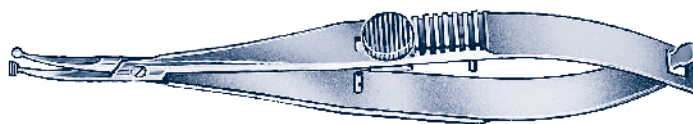
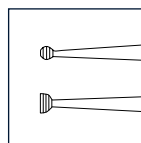
**SA60-2494-00**  
BURATTO

LASIK Flap Pinzette  
LASIK Flap forceps  
Pince pour LASIK flap  
Pinza para LASIK flap

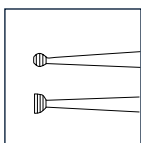
**SA60-2495-50**  
McPHERSON

5 mm  
IOL Pinzette, abgewinkelt,  
Fadenplatte  
IOL forceps, angled, tying  
platform  
Pince pour IOL, coudée, avec  
plateaux  
Pinza para IOL, angulada, con  
plataforma

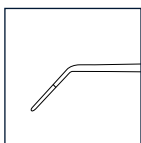

**SA60-2497-12** = 12,0 mm

**SA60-2497-75** = 7,5 mm

**SA60-2497-90** = 9,0 mm

**KELMAN**

Micro-Pinzette, ohne Zähne, mit Fadenplatte

Micro-forceps, angled, with platform

Micro-pince, coudée, avec plateaux

Pinza para micro-cirugia, angulada, con plataforma



**SA60-2498-11**

Implantationspinzette, abgewinkelt, 1 x 1 Zahn

Implantation forceps, angled, 1 x 1 teeth

Pince de implantation, coudée, 1 x 1 griffes

Pinza para implantación, angulada, 1 x 1 dientes

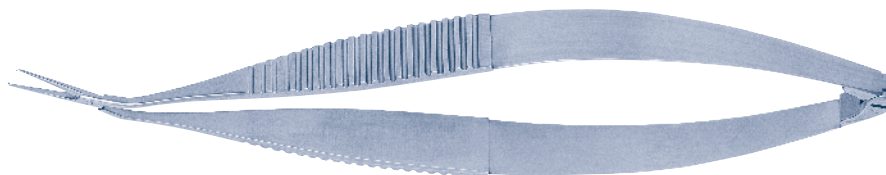
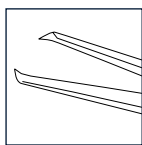

**SA60-2672-11**

**BONN-McPHERSON**

Nahtpinzette, abgewinkelt, mit Fadenplatte

Tying forceps, angled, with tying platform

Pince à suture, coudée, avec plateaux

Pinza para sutura, angulada, con plataforma

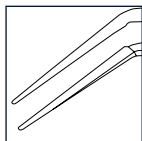

**SA60-2499-75**

**KELMAN-McPHERSON**

7,5 mm

Mikro-Pinzette, abgewinkelt, mit Fadenplatte

Micro-forceps, angled, with platform

Micro-pince, coudée, avec plateaux

Pinza para micro-cirugia, angulada, con plataforma



**SA60-6452-00**

**AKAHOSHI**

120 mm

Pre-Chopper

gerade

straight

droit

recta



## KAPSELPINZETTEN

## CAPSULE FORCEPS

## PINCES CAPSULAIRES

## PINZAS CAPSULARES

### SA60-2505-00

#### ARRUGA

Kapselpinzette  
Capsule forceps  
Pince capsulaire  
Pinza capsular



### SA60-2507-00

#### ARRUGA-KIRBY

Kapselpinzette  
Capsule forceps  
Pince capsulaire  
Pinza capsular

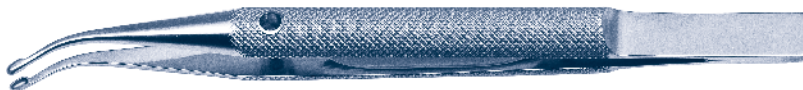

### SA60-2513-00

#### ARRUGA-NIZETIC

Kapselpinzette  
Capsule forceps  
Pince capsulaire  
Pinza capsular



### SA60-2517-00

#### DODICK

Kernspalt-Pinzette, gekreuzt, sehr fein  
Micro Nucleus Cracker, cross action  
Séparateur pour noyau, très fine  
Separador para núcleo de cristalino



## BINDEHAUTPINZETTEN

## CONJUNCTIVAL FORCEPS

## PINCES À CONJUNCTIVA

## PINZA PARA CONJUNCTIVA

### SA60-2524-45

#### DRAEGER

Bindehautpinzette  
Conjunctival forceps  
Pince a conjunctiva  
Pinza para conjunctiva

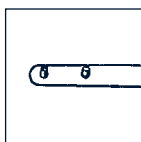

### SA60-2525-12

#### POLACK

0,12 mm, 45°  
Doppelkornealpinzette, 1 x 2 Zähne  
Corneal suturing forceps, 1 x 2 teeth,  
Pince corneal, 1 x 2 griffes  
Pinza para sutura, 1 x 2 dientes

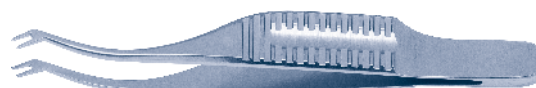
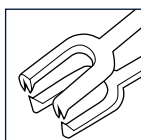

**FIXIERPINZETTEN**  
**FIXATION FORCEPS**

**PINCES À FIXER**  
**PINZAS DE FIJACIÓN**

**SA60-2531-12**  
**BORES**

0,12 mm, 45°  
Doppelkornealpinzette, 1 x 2 Zähne  
Corneal suturing forceps, 1 x 2 teeth  
Pince corneal, 1 x 2 griffes  
Pinza para sutura, 1 x 2 dientes

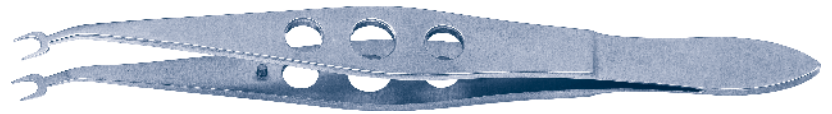
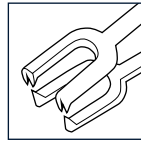

**SA60-2532-00**  
**GRAEFE**

Fixierpinzette ohne Schloss  
Fixation forceps without catch  
Pince a fixer sans ressort  
Pinza de fijación sin muelle

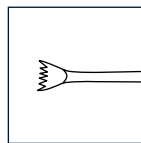

2532-00

**SA60-2533-00**  
**GRAEFE**

Fixierpinzette mit Schloss  
Fixation forceps with catch  
Pince a fixer avec ressort  
Pinza de fijación con muelle

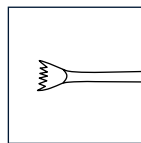

**SA60-2537-00**  
**JESS**

Fixierpinzette  
Fixation forceps  
Pince a fixer  
Pinza de fijación

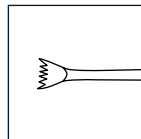

**SA60-2539-00**  
**CASTROVIEJO**

Fixierpinzette, 1 x 1 Zahn  
Fixation forceps, 1 x 1 tooth  
Pince a fixer, 1 x 1 griffe  
Pinza de fijación, 1 x 1 diente

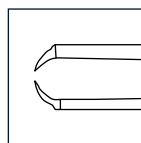

**SA60-2540-00**  
**CASTROVIEJO**

Fixierpinzette, 2 x 2 Zähne  
Fixation forceps, 2 x 2 teeth  
Pince a fixer, 2 x 2 griffes  
Pinza de fijación, 2 x 2 dientes

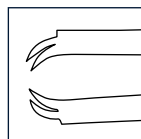

**SA60-2541-00**

Fixierpinzette, 1 x 2 Zähne  
Fixation forceps, 1 x 2 teeth  
Pince a fixer, 1 x 2 griffes  
Pinza de fijación, 1 x 2 dientes

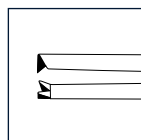

**SA60-2542-12**

GREEN

Fixierpinzette, ohne Schloss  
 Fixation forceps, without catch  
 Pince a fixer, sans ressort  
 Pinza de fijación, sin muelle

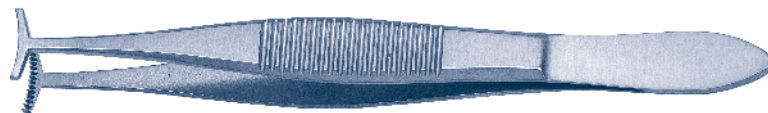

2542-12

**SA60-2543-12**

GREEN

Fixierpinzette, mit Schloss  
 Fixation forceps, with catch  
 Pince a fixer, avec ressort  
 Pinza de fijación, con muelle

**SA60-2545-00**

BARRAQUER

Fixierpinzette  
 Fixation forceps  
 Pince a fixer  
 Pinza de fijación

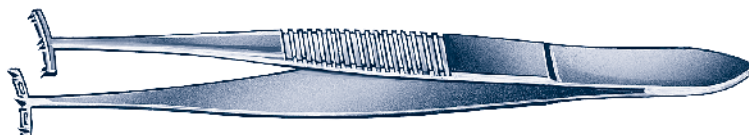

**SA60-2546-00**

TROUTMAN

Zügelnahtpinzette  
 Superior rectus forceps  
 Pince pour le muscle droit supérieur  
 Pinza para superior rectus

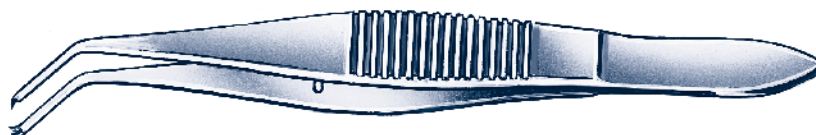

**SA60-2548-12**

KREMER

Fixierpinzette mit Schloss, sehr fein  
 Fixation forceps with catch, very delicate  
 Pince a fixation pour la cornee, très fine  
 Pinza de fijación corneale

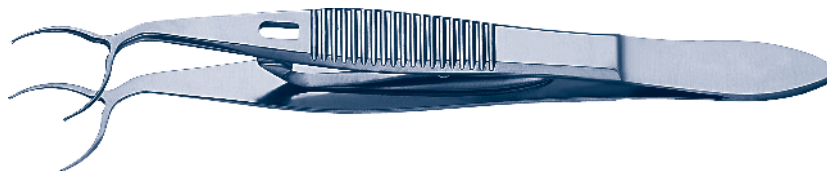

**SA60-2549-00**

REMKY

Zügelnahtpinzette  
 Superior rectus forceps  
 Pince pour le muscle droit supérieur  
 Pinza, para superior rectus



**PINZETTEN FÜR SCHIELOPERATION**  
**STRABISMUS FORCEPS**

**PINCES À STRABISME**  
**PINZAS PARA ESTRABISMO**

**SA60-2550-12**

Pinzette für Schiel-OP, 1 x 2 Zähne  
 Strabismus forceps, 1 x 2 teeth  
 Pince à strabisme, 1 x 2 griffes  
 Pinza para estrabismo, 1 x 2 dientes

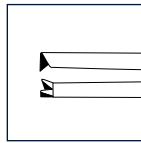

**SA60-2551-12**

Pinzette für Schiel-OP, gerieft  
 Strabismus forceps, serrated jaws  
 Pince à strabisme, striée  
 Pinza para estrabismo, estriada

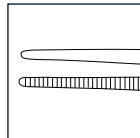

**SA60-2553-00**

Pinzette für Schiel-OP, kreuzgerieft  
 Strabismus forceps, cross-serrated jaws  
 Pince à strabisme, striée  
 Pinza para estrabismo, estriada

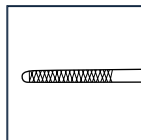

**SA60-2554-00**

Pinzette für Schiel-OP, kreuzgerieft,  
 1 x 2 Zähne  
 Strabismus forceps, cross-serrated jaws,  
 1 x 2 teeth  
 Pince à strabisme, striée, 1 x 2 griffes  
 Pinza para estrabismo, estriada,  
 1 x 2 dientes

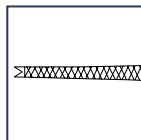

**SA60-2555-15**

Pinzette für Schiel-OP, 1,5 mm, schmal  
 Strabismus forceps, 1,5 mm, slim  
 Pince à strabisme, 1,5 mm, étroite  
 Pinza para estrabismo, 1,5 mm, estrecha



**SA60-2556-23**

Pinzette für Schiel-OP, 2,4 mm, breit  
 Strabismus forceps, 2,4 mm, wide  
 Pince à strabisme, 2,4 mm, large  
 Pinza para estrabismo, 2,4 mm, ancha



**SA60-2558-10**

Pinzette für Schiel-OP  
 Strabismus forceps  
 Pince à strabisme  
 Pinza para estrabismo



**SA60-2564-11**

HATA

Muskelpinzette, rechts  
 Advancement forceps, right  
 Pince a musculaire, à droit  
 Pinza muscular, derecha

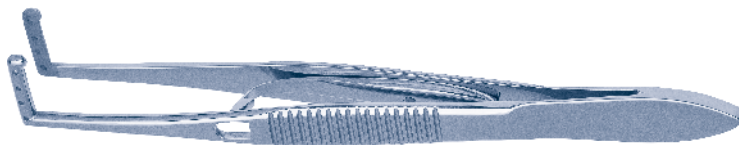

**SA60-2565-11**

HATA

Muskelpinzette, links  
 Advancement forceps, left  
 Pince a musculaire, à gauche  
 Pinza muscular, izquierda



**SA60-2566-04**

PRINCE

Muskelpinzette, rechts  
 Advancement forceps, right  
 Pince a musculaire, à droit  
 Pinza muscular, derecha



**SA60-2567-04**

PRINCE

Muskelpinzette, links  
 Advancement forceps, left  
 Pince a musculaire, à gauche  
 Pinza muscular, izquierda



**SA60-2568-03**

SATTLER

Muskelpinzette, rechts  
 Advancement forceps, right  
 Pince a musculaire, à droit  
 Pinza muscular, derecha

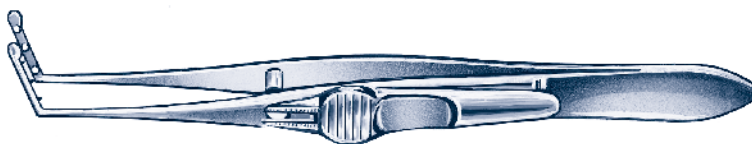

**SA60-2569-03**

SATTLER

Muskelpinzette, links  
 Advancement forceps, left  
 Pince a musculaire, à gauche  
 Pinza muscular, izquierda

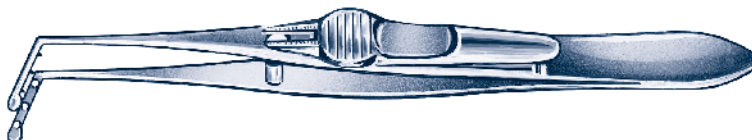

**SA60-2570-04**  
JAMESON

Muskelpinzette, rechts, für Kinder  
Advancement forceps, right, for children  
Pince a musculaire, à droit, pour enfants  
Pinza muscular, derecha, para niños



**SA60-2570-07**  
JAMESON

Muskelpinzette, rechts  
Advancement forceps, right  
Pince a musculaire, à droit  
Pinza muscular, derecha



**SA60-2571-04**  
JAMESON

Muskelpinzette, links, für Kinder  
Advancement forceps, left, for children  
Pince a musculaire, à gauche, pour enfants  
Pinza muscular, izquierda, para niños

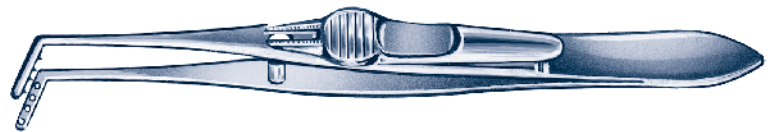

**SA60-2571-07**  
JAMESON

Muskelpinzette, links  
Advancement forceps, left  
Pince a musculaire, à gauche  
Pinza muscular, izquierda

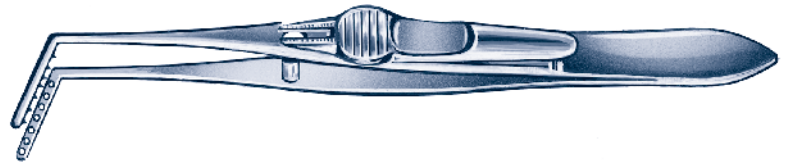

**SA60-2572-00**  
WORTH

Muskelpinzette, rechts  
Advancement forceps, right  
Pince a musculaire, à droit  
Pinza muscular, derecha

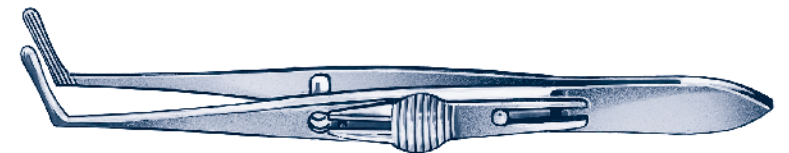

**SA60-2573-00**  
WORTH

Muskelpinzette, links  
Advancement forceps, left  
Pince a musculaire, à gauche  
Pinza muscular, izquierda

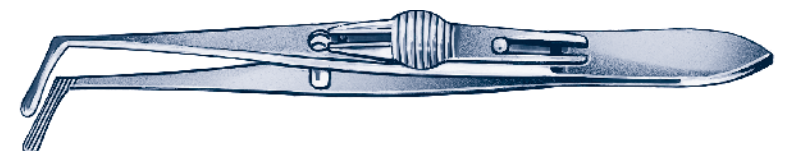

**SA60-2575-00**  
BLASCOVIC

Muskelpinzette, rechts  
Advancement forceps, right  
Pince a musculaire, à droit  
Pinza muscular, derecha

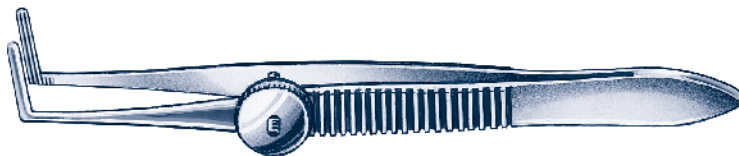

**SA60-2576-00**  
BLASCOVIC

Muskelpinzette, links  
Advancement forceps, left  
Pince a musculaire, à gauche  
Pinza muscular, izquierda

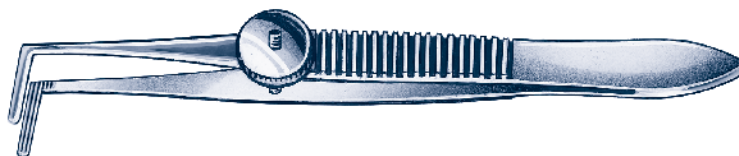

**SA60-2578-20** = 20 mm  
**SA60-2578-27** = 27 mm

BERKE

Muskelpinzette für Ptosis  
Ptosis forceps  
Pince musculaire pour ptosis  
Pinza muscular para ptosis

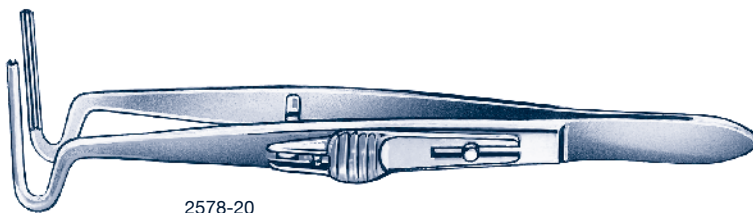

**SA60-2579-10**  
BANGERTER

Muskelklemme  
Muscle clamp  
Pince pour les muscles  
Pinza clamp muscular



**SA60-2582-00**  
WATZKE

Spreizpinzette  
Sleeve spreading forceps  
Pince à écarter  
Pinza para extender



**SA60-2584-28**

**SNELLEN**

28 mm

Entropionspinzette, links  
Entropium forceps, left  
Pince á entropion, à gauche  
Pinza para entropión, izquierda

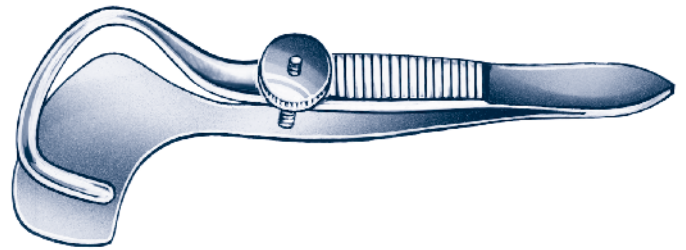

**SA60-2585-28**

**SNELLEN**

28 mm

Entropionspinzette, rechts  
Entropium forceps, right  
Pince á entropion, à droit  
Pinza para entropión, derecha

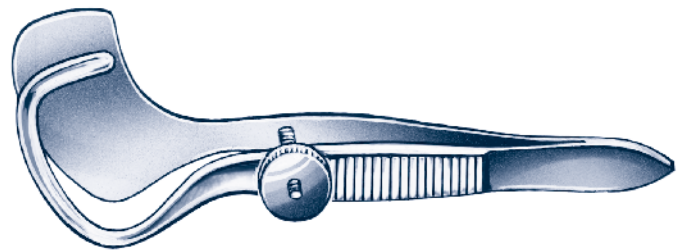

**SA60-2598-00**

**TEARSE**

Meibom Pinzette  
Meibomian expressor forceps  
Pince presse  
Pinza para apagar las glándulas



## CHALAZIONSPINZETTEN

## CHALAZION FORCEPS

## PINCES À CHALAZION

## PINZAS DE CHALAZION

- SA60-2600-20** = 20 mm
- SA60-2600-26** = 26 mm
- SA60-2600-31** = 31 mm
- SA60-2600-34** = 33 mm

### DESMARRES

Chalazionspinzette  
Chalazion forceps  
Pince à chalazion  
Pinza de chalazion

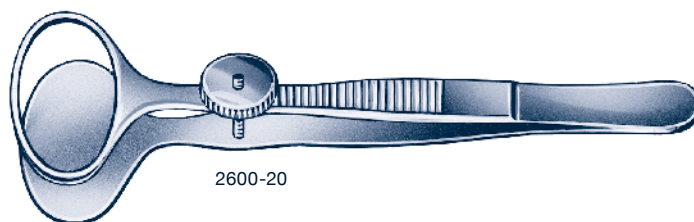

### SA60-2602-08

#### AYER

Chalazionspinzette  
Chalazion forceps  
Pince à chalazion  
Pinza de chalazion



### SA60-2604-08

#### LAMBERT

Chalazionspinzette  
Chalazion forceps  
Pince à chalazion  
Pinza de chalazion



### SA60-2606-09

#### CAUER

Chalazionspinzette  
Chalazion forceps  
Pince à chalazion  
Pinza de chalazion



### SA60-2607-12

#### HUNT

Chalazionspinzette  
Chalazion forceps  
Pince à chalazion  
Pinza de chalazion

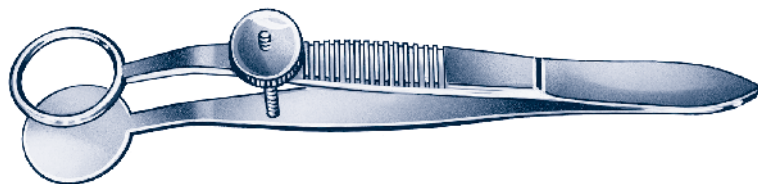

### SA60-2608-13

#### BAIRD

Chalazionspinzette  
Chalazion forceps  
Pince à chalazion  
Pinza de chalazion

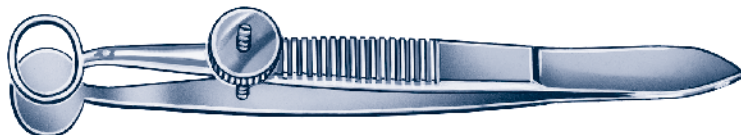

### SA60-2609-11

#### LORDAN

Chalazionspinzette  
Chalazion forceps  
Pince à chalazion  
Pinza de chalazion

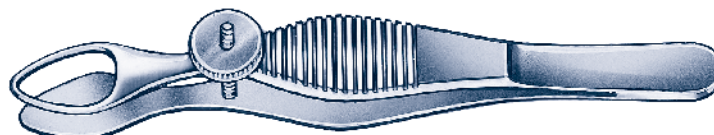

## CILIENPINZETTEN

## CILIA FORCEPS

## PINCE À ÉPILER LES CILS

## PINZAS DEPILATORIAS

### SA60-2621-00

#### HENRY

Cilienpinzette  
Cilia forceps  
Pince à épiler  
Pinza depilatoria

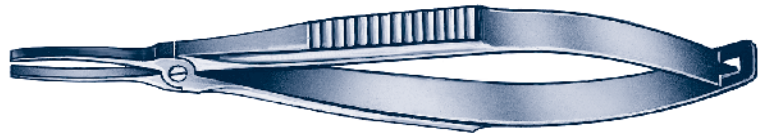

### SA60-2622-00

#### GRADLE

Cilienpinzette  
Cilia forceps  
Pince à épiler  
Pinza depilatoria

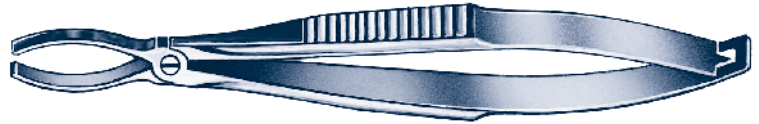

### SA60-2623-00

#### BARRAQUER

Cilienpinzette, Standardmodell  
Cilia forceps, standard model  
Pince à épiler, modèle standard  
Pinza depilatoria, typo standard



### SA60-2623-06

#### BARRAQUER

Cilienpinzette, feines Modell  
Cilia forceps, fine model  
Pince à épiler, modèle fine  
Pinza depilatoria, delicadisima



### SA60-2624-00

#### SCHWEIZER MODELL

Cilienpinzette  
Cilia forceps  
Pince à épiler  
Pinza depilatoria



### SA60-2626-15

#### SCHWEIZER MODELL

Cilienpinzette  
Cilia forceps  
Pince à épiler  
Pinza depilatoria



### SA60-2628-00

#### BEER

Cilienpinzette  
Cilia forceps  
Pince à épiler  
Pinza depilatoria



**SA60-2629-00**  
SAUPE

Cilienpinzette  
Cilia forceps  
Pince à épiler  
Pinza depilatoria



**SA60-2630-00**  
HEIDELBERGER MODELL

Cilienpinzette  
Cilia forceps  
Pince à épiler  
Pinza depilatoria



**SA60-2632-00**  
SPEEMANN

Fremdkörperpinzette  
Jeweler type foreign body forceps  
Pince pour corps étrangers  
Pinza para cuerpos extraños typó jeweler



**SA60-2635-00**  
SHAAF

Fremdkörperpinzette  
Foreign body forceps  
Pince pour corps étrangers  
Pinza para cuerpos extraños

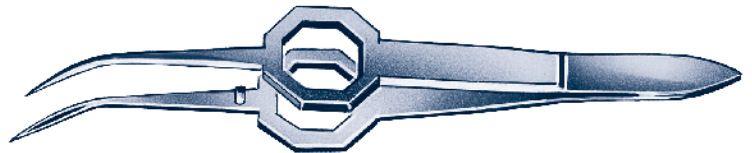

**SA60-2641-09**  
BARRAQUER

Vorderkammerpinzette  
Secondary membrane forceps  
Pince pour la chambre antérieure  
Pinza para la cámara anterior

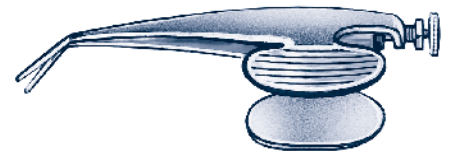

**SA60-2645-00**

Pinzette für Sklera-Stopfen  
Forceps for scleral plugs  
Pince pour obturateur scléral  
Pinza para tapón escleral

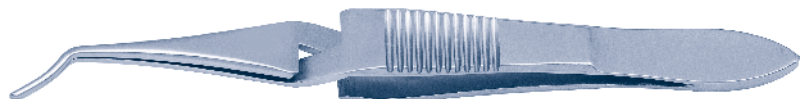
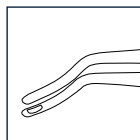

**NAHTPINZETTEN**  
**SUTURE FORCEPS**

**PINCES À SUTURES**  
**PINZAS PARA SUTURAS**

**SA60-2665-12** = 0,12 mm  
**SA60-2665-35** = 0,35 mm  
**SA60-2665-60** = 0,60 mm  
**SA60-2665-90** = 0,90 mm  
**CASTROVIEJO**

Nahtpinzette  
Suture forceps  
Pince à suture  
Pinza para sutura

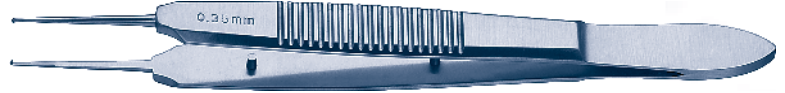

2665-35

**SA60-2666-50** = 0,50 mm  
**CASTROVIEJO**

Nahtpinzette, abgewinkelt  
Suture forceps, angled  
Pince à suture, coudée  
Pinza para sutura, angulosa

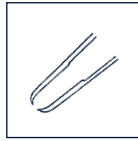

**SA60-2667-12** = 0,12 mm  
**SA60-2667-35** = 0,35 mm  
**SA60-2667-60** = 0,60 mm  
**CASTROVIEJO**

Nahtpinzette, breiter Griff  
Suture forceps, wide handle  
Pince à suture  
Pinza para sutura

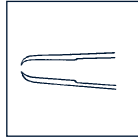

2667-12

**SA60-2664-75**

7,5 mm  
Fadenpinzette, abgewinkelt, ohne Zähne  
Tying forceps, angled, without teeth  
Pince à fils, coudée, sans griffes  
Pinza para anudar, angulosa, sin dientes



**SA60-2668-45**  
**MODELL TUEBINGEN**

Fadenpinzette, gebogen, ohne Zähne  
Tying forceps, curved, without teeth  
Pince à fils, courbe, sans griffes  
Pinza para anudar, curva, sin dientes



**SA60-2669-45** = 0,45 mm  
**SA60-2669-60** = 0,60 mm  
**CASTROVIEJO**

Fadenpinzette, gerade, ohne Zähne  
Tying forceps, straight, without teeth  
Pince à fils, droite, sans griffes  
Pinza para anudar, recta, sin dientes



2669-60

**SA60-2670-00**  
MODELL TUEBINGEN

Fadenpinzette, gerade, 6 mm Fadenplatte, ohne Zähne  
Tying forceps, straight, 6 mm tying platform, without teeth  
Pince à fils, droite, 6 mm plateaux, sans griffes  
Pinza para anudar, recta, 6 mm plataforma, sin dientes

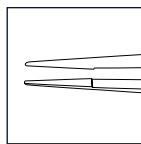

**SA60-2671-10**  
BECHERT-McPHERSON

Fadenpinzette  
Tying forceps  
Pince à fils  
Pinza para anudar



**SA60-2672-11**  
BONN-McPHERSON

Fadenpinzette, abgewinkelt, mit Fadenplatte  
Tying forceps, angled, with tying platform  
Pince à fils, coudée, avec plateaux  
Pinza para anudar, angulada, con plataforma



**SA60-2673-00**  
PAUFIQUE

Nahtpinzette, Standardmodell  
Suture forceps, standard model  
Pince à suture, modèle standard  
Pinza para sutura, tipo standard

**SA60-2673-35**  
PAUFIQUE

Nahtpinzette, feines Modell  
Suture forceps, fine model  
Pince à suture, modèle fine  
Pinza para sutura, tipo delicadísima

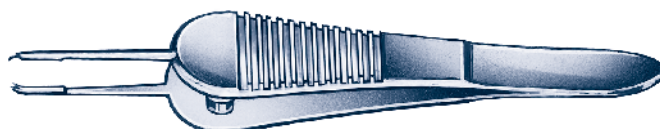

2673-00

**SA60-2676-40**  
PAUFIQUE

Fadenpinzette, Fadenplatte 0,4 mm breit, ohne Zähne  
Tying forceps, tying platform 0,4 mm wide, without teeth  
Pince à fils, avec plateaux, 0,4 mm, sans griffes  
Pinza para anudar, con plataforma, sin dientes

**SA60-2674-00**

**ST. MARTIN**

Nahtpinzette, 1 x 2 Zähne  
Suturing forceps, 1 x 2 teeth  
Pince à suture, 1 x 2 griffes  
Pinza para sutura, 1 x 2 dientes



**SA60-2675-00**

**MOORFIELD**

Nahtpinzette  
Suturing forceps  
Pince à suture  
Pinza para sutura



**SA60-2676-00**

**TENNANT**

Fadenpinzette, 6 mm Fadenplatte, ohne Zähne  
Tying forceps, 6 mm tying platform, without teeth  
Pince à fils, avec plateaux 6 mm, sans griffes  
Pinza para anudar, con plataforma 6 mm, sin dientes



**SA60-2677-00**

**TENNANT**

Fadenpinzette, gebogen, 6 mm Fadenplatte, ohne Zähne  
Tying forceps, curved, 6 mm tying platform, without teeth  
Pince à fils, courbe, avec plateaux 6 mm, sans griffes  
Pinza para anudar, curva, con plataforma 6 mm, sin dientes



**SA60-2698-08**

**McPHERSON**

Nahtpinzette, gerade, mit Fadenplatte  
Suture forceps, straight, with tying platform  
Pince à suture, droite, avec plateaux  
Pinza para sutura, recta, con plataforma

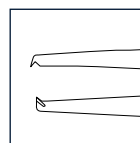

**SA60-2678-00**

**BECHERT-McPHERSON**

Fadenpinzette, abgewinkelt, mit Fadenplatte  
Tying forceps, angled, with tying platform  
Pince à fils, coudée, avec plateaux  
Pinza para anudar, angulada, con plataforma



**SA60-2698-06**

**BONNER MODELL**

Nahtpinzette, gerade, 1 x 2 Zähne, Fadenplatte  
Suture Forceps, straight, 1 x 2 teeth, tying platform  
Pince pour sutures, droite, 1 x 2 griffes, plateaux  
Pinza de disección, recta, 1 x 2 dientes, plataforma

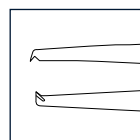

**NAHTPINZETTEN**  
**SUTURE FORCEPS**

**PINCES À SUTURES**  
**PINZAS PARA SUTURAS**

**SA60-2680-25** = 0,25 mm  
**SA60-2680-40** = 0,40 mm  
COLIBRI

Nahtpinzette, ohne Fadenplatte  
Suture forceps, without tying platform  
Pince à suture, sans plateaux  
Pinza para sutura, sin plataforma

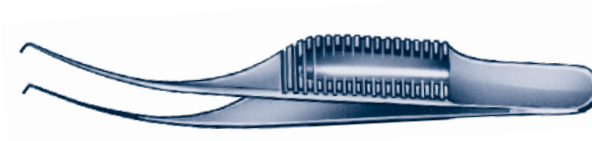
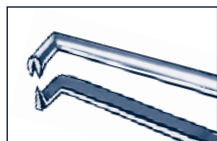

**SA60-2681-25** = 0,25 mm  
**SA60-2681-40** = 0,40 mm  
COLIBRI

Nahtpinzette, mit Fadenplatte  
Suture forceps, with tying platform  
Pince à suture, avec plateaux  
Pinza para sutura, con plataforma

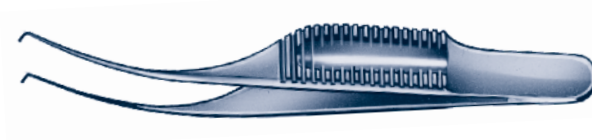

**SA60-2682-12** = 0,12 mm  
**SA60-2682-25** = 0,25 mm  
**SA60-2682-40** = 0,40 mm  
COLIBRI-TROUTMAN

Nahtpinzette, Zähne 45°, ohne Fadenplatte  
Suture forceps, teeth 45°, without tying platform  
Pince à suture, griffes 45°, sans plateaux  
Pinza para sutura, dientes 45°, sin plataforma

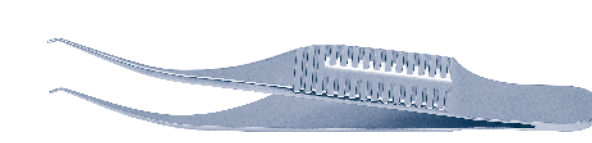
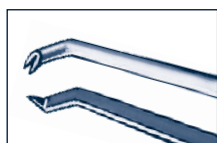

**SA60-2683-12** = 0,12 mm  
**SA60-2683-25** = 0,25 mm  
**SA60-2683-40** = 0,40 mm  
COLIBRI-TROUTMAN

Nahtpinzette, Zähne 45°, mit Fadenplatte  
Suture forceps, teeth 45°, with tying platform  
Pince à suture, griffes 45°, avec plateaux  
Pinza para sutura, dientes 45°, con plataforma

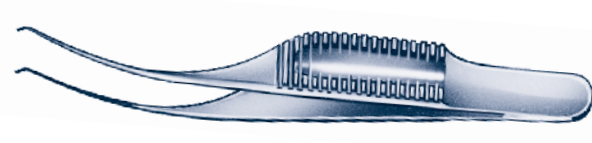
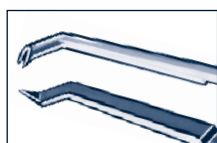

**SA60-2684-12**  
COLIBRI

Nahtpinzette, kurze kräftige Zähne, mit Fadenplatte  
Suture forceps, short strong teeth, with tying platform  
Pince à suture, griffes courtes, avec plateaux  
Pinza para sutura, dientes cortos, con plataforma

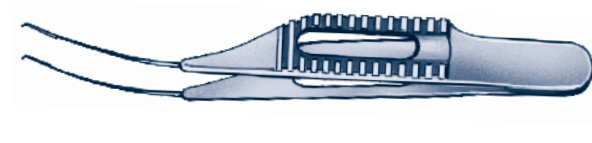
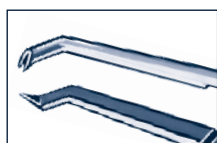

**SA60-2685-12**

**ZUERCHER MODELL**

Nahtpinzette, 1 x 2 Zähne, sehr fein, mit Fadenplatte  
Suture forceps, 1 x 2 teeth, very delicate, with tying platform  
Pince à suture, 1 x 2, griffes, extra fin, avec plateaux  
Pinza para sutura, 1 x 2 dientes, delicadísima, con plataforma

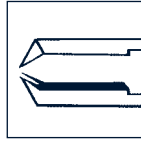

**SA60-2685-25**

**ZUERCHER MODELL**

Nahtpinzette, 1 x 2 Zähne, Standardmodell, mit Fadenplatte  
Suture forceps, 1 x 2 teeth, standard modell, with tying platform  
Pince à suture, 1 x 2, griffes, modèle standard, avec plateaux  
Pinza para sutura, 1 x 2 dientes, typo standard, con plataforma

**SA60-2685-26**

**ZUERCHER MODELL**

Nahtpinzette, gewinkelt, 1 x 2 Zähne, Standardmodell, mit Fadenplatte  
Suture forceps, angled, 1 x 2 teeth, standard modell, with tying platform  
Pince à suture, coudée, 1 x 2, griffes, modèle standard, avec plateaux  
Pinza para sutura, angulada, 1 x 2 dientes, typo standard, con plataforma

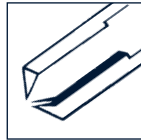

**SA60-2686-12** = 0,12 mm

**SA60-2686-25** = 0,25 mm

**SA60-2686-40** = 0,40 mm

**COLIBRI**

Nahtpinzette, Zähne 90°, ohne Fadenplatte  
Suture forceps, teeth 90°, without tying platform  
Pince à suture, griffes 90°, sans plateaux  
Pinza para sutura, dientes 90°, sin plataforma

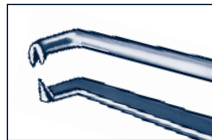

**SA60-2687-12** = 0,12 mm

**SA60-2687-25** = 0,25 mm

**SA60-2687-40** = 0,40 mm

**COLIBRI**

Nahtpinzette, Zähne 90°, mit Fadenplatte  
Suture forceps, teeth 90°, with tying platform  
Pince à suture, griffes 90°, avec plateaux  
Pinza para sutura, dientes 90°, con plataforma

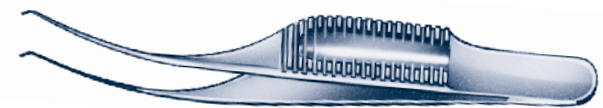

**SA60-2688-00**

**BARRAQUER**

Fadenlöspinzette, spitz, ohne Zähne  
Suture removal forceps, pointed, without teeth  
Pince tire-fils, pointu, sans griffes  
Pinza para quitar suturas, aguda, sin dientes

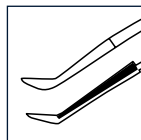

**SA60-2690-00**

ENGLISCHES MODELL

Nahtpinzette, gerade, ohne Zähne, mit Fadenplatte  
Suture forceps, straight, without teeth, with tying platform

Pince à suture, droite, sin griffes, avec plataux  
Pinza para sutura, recta, sin dientes, con plataforma

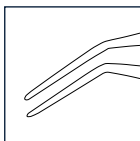

**SA60-2691-00**

ENGLISCHES MODELL

Nahtpinzette, abgewinkelt, ohne Zähne, mit Fadenplatte  
Suture forceps, angled, without teeth, with tying platform

Pince à suture, coudée, sin griffes, avec plataux  
Pinza para sutura, angulada, sin dientes, con plataforma

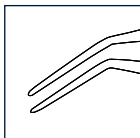

**SA60-2693-25**

ENGLISCHES MODELL

Nahtpinzette, gerade, mit Zähnen, mit Fadenplatte  
Suture forceps, straight, with teeth, with tying platform

Pince à suture, droite, avec griffes, avec plataux  
Pinza para sutura, recta, con dientes, con plataforma

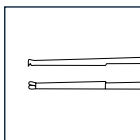

**SA60-2694-25**

ENGLISCHES MODELL

Nahtpinzette, abgewinkelt, mit Zähne, mit Fadenplatte  
Suture forceps, angled, with teeth, with tying platform

Pince à suture, coudée, avec griffes, avec plataux  
Pinza para sutura, angulada, con dientes, con plataforma

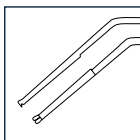

**SA60-2695-25**

ENGLISCHES MODELL

Nahtpinzette, s-förmig, mit Zähne, mit Fadenplatte  
Suture forceps, s-shaped, with teeth, with tying platform

Pince à suture, avec griffes, avec plataux  
Pinza para sutura, con dientes, con plataforma

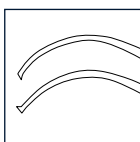

**SA60-2696-25**

ENGLISCHES MODELL

Nahtpinzette, gerade, mit Zähne, ohne Fadenplatte  
Suture forceps, straight, with teeth, without tying platform

Pince à suture, droite, avec griffes, sans plataux  
Pinza para sutura, recta, con dientes, sin plataforma

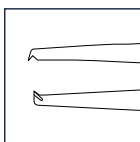

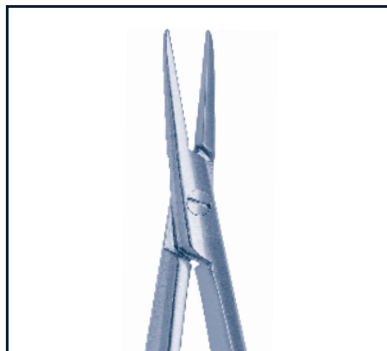

Welcher Nadelhalter für welche Nadel?  
Which Needle Holder for which Needle?  
Quel porte-aiguille pour quelle aiguille?  
¿Qué porta agujas para qué aguja?

Nadelhalter Needle Holder Porte-Aiguilles Porta-Agujas		Nadelstärke Needle size Taille de l'aiguille El tamaño de la aguja
0,5 mm		max. 9 x 0
1,0 mm		max. 7 x 0
1,5 mm		max. 6 x 0
2,0 mm		max. 5 x 0
2,5 mm		max. 3 x 0

**SA60-2700-10**  
BARRAQUER

gebogen, mit Schloss, Maul 0,75 mm  
curved, with catch, jaw 0,75 mm  
courbe, avec ressort, mors 0,75 mm  
curva, con muelle, boca 0,75 mm

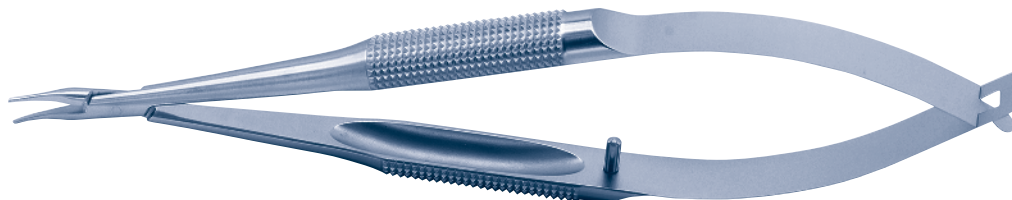

SA60-2700-10

**SA60-2702-10**  
BARRAQUER  
(Original)

gebogen, ohne Schloss, Maul 0,75 mm  
curved, without catch, jaw 0,75 mm  
courbe, sans ressort, mors 0,75 mm  
curva, sin muelle, boca 0,75 mm

**SA60-2704-13**  
KALT

gerade, mit Schloss  
straight, with catch  
droit, avec ressort  
recta, con muelle

**SA60-2705-13**  
KALT

gebogen, mit Schloss  
curved, with catch  
courbe, avec ressort  
curva, con muelle

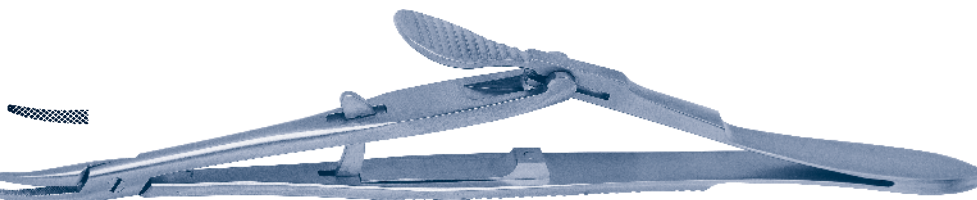

SA60-2705-13

**SA60-2712-13**  
ARRUGA

gerade, mit Schloss  
straight, with catch  
droit, avec ressort  
recta, con muelle

**SA60-2713-13**  
ARRUGA

gebogen, mit Schloss  
curved, with catch  
courbe, avec ressort  
curva, con muelle

**SA60-2712-99**  
ARRUGA

gerade, ohne Schloss  
straight, without catch  
droit, sans ressort  
recta, sin muelle

**SA60-2716-16**  
CASTROVIEJO-KALT

gerade, mit Schloss  
straight, with catch  
droit, avec ressort  
recta, con muelle

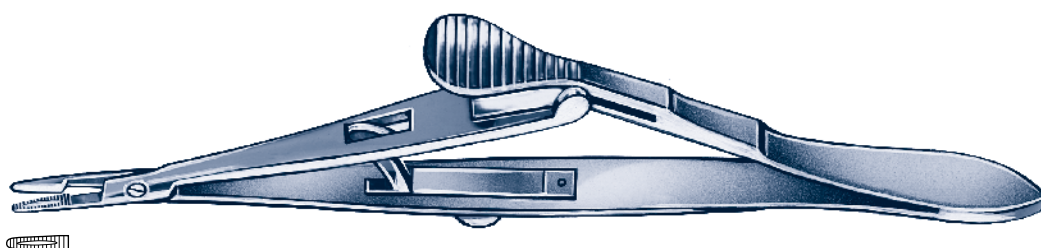

**SA60-2732-07**  
**CASTROVIEJO**

gerade, extra fein, ohne Sperre,  
Maul 0,7 mm  
straight, extremely delicate, without catch,  
jaw 0,7 mm  
droit, très fine, sans ressort, mors  
0,7 mm  
recta, muy fina, sin muelle, boca 0,7 mm

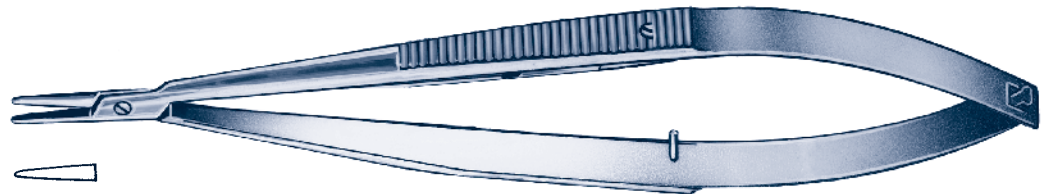

**SA60-2732-12**  
**CASTROVIEJO**

gerade, ohne Sperre, Maul 1,0 mm  
straight, without catch, jaw 1,0 mm  
droit, sans ressort, mors 1,0 mm  
recta, sin muelle, boca 1,0 mm

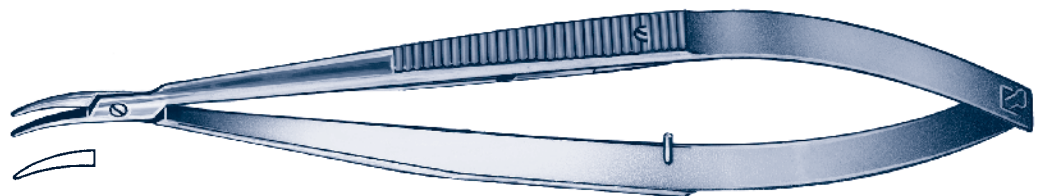

**SA60-2733-07**  
**CASTROVIEJO**

gebogen, extra fein, ohne Sperre,  
Maul 0,7 mm  
curved, extremely delicate, without catch,  
jaw 0,7 mm  
courbe, très fine, sans ressort,  
mors 0,7 mm  
curva, muy fina, sin muelle, boca 0,7 mm

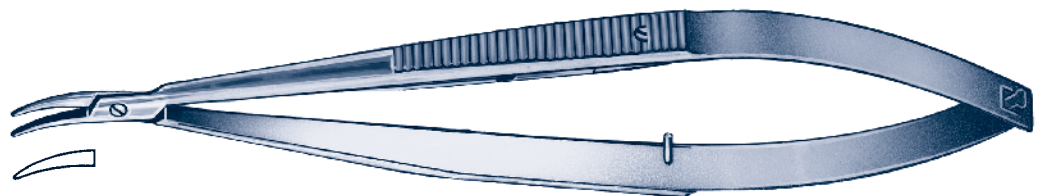

**SA60-2733-12**  
**CASTROVIEJO**

gebogen, ohne Sperre, Maul 1,0 mm  
curved, without catch, jaw 1,0 mm  
courbe, sans ressort, mors 1,0 mm  
curva, sin muelle, boca 1,0 mm

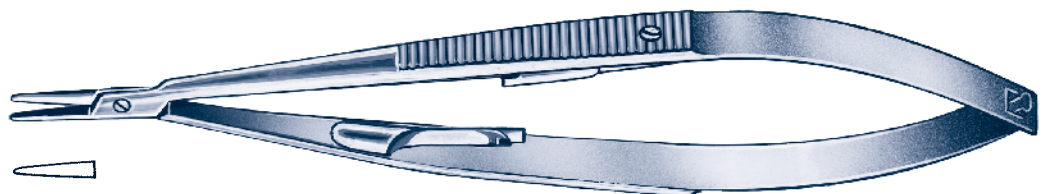

**SA60-2734-07**  
**CASTROVIEJO**

gerade, extra fein, mit Sperre, Maul 0,7 mm  
straight, extremely delicate, with catch, jaw  
0,7 mm  
droit, très fine, avec ressort, mors 0,7 mm  
recta, muy fina, con muelle, boca 0,7 mm



**SA60-2734-12**  
**CASTROVIEJO**

gerade, mit Sperre, Maul 1,0 mm  
straight, with catch, jaw 1,0 mm  
droit, avec ressort, mors 1,0 mm  
recta, con muelle, boca 1,0 mm



**SA60-2735-07**  
**CASTROVIEJO**

gebogen, extra fein, mit Sperre,  
Maul 0,7 mm  
curved, extremely delicate, with catch,  
jaw 0,7 mm  
courbe, très fine, avec ressort,  
mors 0,7 mm  
curva, muy fina, con muelle, boca 0,7 mm



**SA60-2735-12**  
**CASTROVIEJO**

gebogen, mit Sperre, Maul 1,0 mm  
curved, with catch, jaw 1,0 mm  
courbe, avec ressort, mors 1,0 mm  
curva, con muelle, boca 1,0 mm

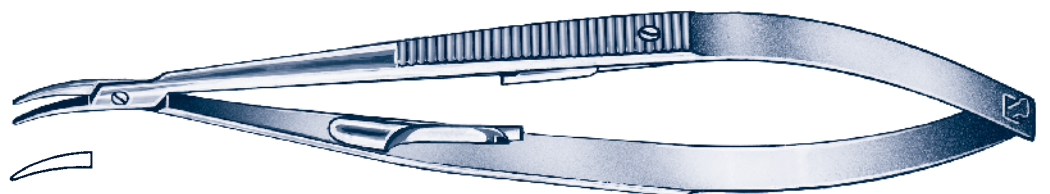

**SA60-2752-10**  
**BARRAQUER**

gerade, ohne Sperre, Maul 1,0 mm  
straight, without catch, jaw 1,0 mm  
droit, sans ressort, mors 1,0 mm  
recta, sin muelle, boca 1,0 mm

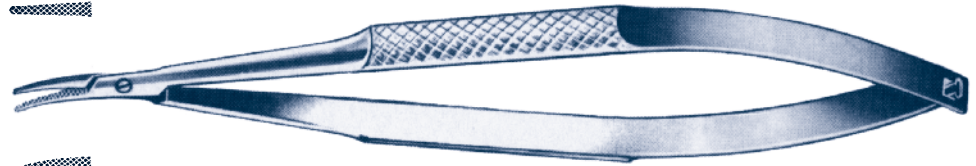

**SA60-2753-10**  
**BARRAQUER**

gebogen, ohne Sperre, Maul 1,0 mm  
curved, without catch, jaw 1,0 mm  
courbe, sans ressort, mors 1,0 mm  
curva, sin muelle, boca 1,0 mm



SA60-2753-10

**SA60-2754-10**  
**BARRAQUER**

gerade, mit Sperre, Maul 1,0 mm  
straight, with catch, jaw 1,0 mm  
droit, avec ressort, mors 1,0 mm  
recta, con muelle, boca 1,0 mm

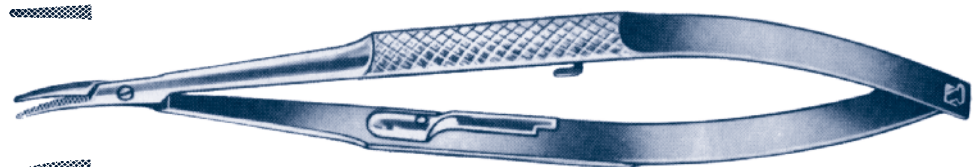

**SA60-2755-10**  
**BARRAQUER**

gebogen, mit Sperre, Maul 1,0 mm  
curved, with catch, jaw 1,0 mm  
courbe, avec ressort, mors 1,0 mm  
curva, con muelle, boca 1,0 mm



2SA60-755-10

**SA60-2757-10**  
**BARRAQUER**

14 cm  
gebogen, ohne Sperre, Maul 1,0 mm  
curved, without catch, jaw 1,0 mm  
courbe, sans ressort, mors 1,0 mm  
curva, sin muelle, boca 1,0 mm

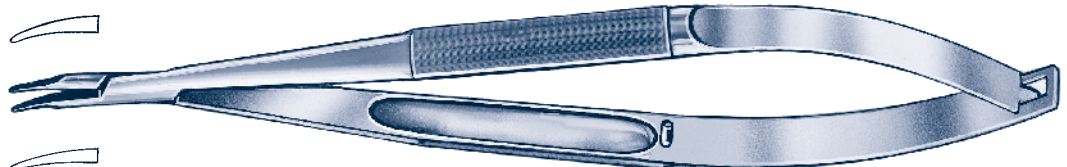

**SA60-2757-75**  
**BARRAQUER**

14 cm  
gebogen, ohne Sperre, Maul 0,75 mm  
curved, without catch, jaw 0,75 mm  
courbe, sans ressort, mors 0,75 mm  
curva, sin muelle, boca 0,75 mm

SA60-2757-10

**SA60-2759-10**  
BARRAQUER

14 cm

gebogen, mit Sperre, Maul 1,0 mm  
curved, with catch, jaw 1,0 mm  
courbe, avec ressort, mors 1,0 mm  
curva, con muelle, boca 1,0 mm

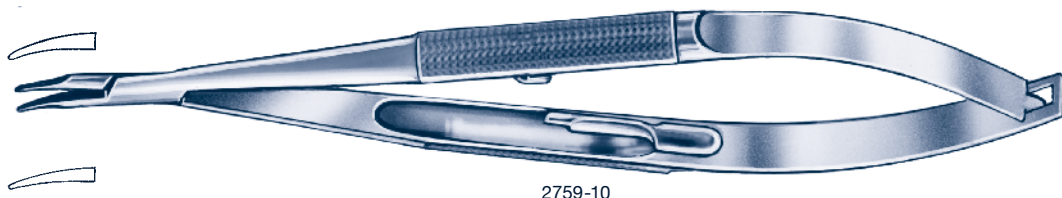

**SA60-2759-75**  
BARRAQUER

14 cm

gebogen, mit Sperre, Maul 0,75 mm  
curved, with catch, jaw 0,75 mm  
courbe, avec ressort, mors 0,75 mm  
curva, con muelle, boca 0,75 mm

**SA60-2762-10**  
BARRAQUER

gerade, ohne Sperre, Maul 1,0 mm  
straight, without catch, jaw 1,0 mm  
droit, sans ressort, mors 1,0 mm  
recta, sin muelle, boca 1,0 mm

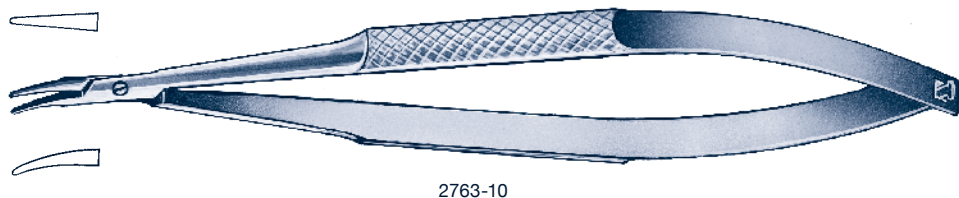

**SA60-2763-10**  
BARRAQUER

gebogen, ohne Sperre, Maul 1,0 mm  
curved, without catch, jaw 1,0 mm  
courbe, sans ressort, mors 1,0 mm  
curva, sin muelle, boca 1,0 mm

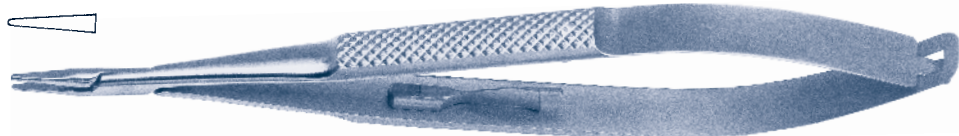

**SA60-2764-10**  
BARRAQUER

gerade, mit Sperre, Maul 1,0 mm  
straight, with catch, jaw 1,0 mm  
droit, avec ressort, mors 1,0 mm  
recta, con muelle, boca 1,0 mm

**SA60-2765-10**  
BARRAQUER

gebogen, mit Sperre, Maul 1,0 mm  
curved, with catch, jaw 1,0 mm  
courbe, avec ressort, mors 1,0 mm  
curva, con muelle, boca 1,0 mm

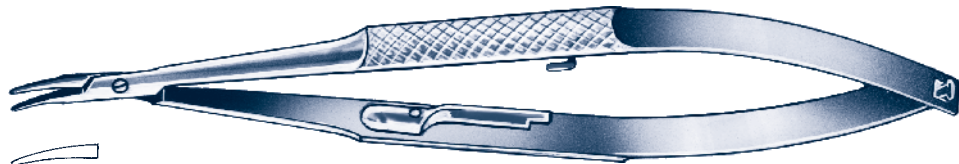

**SA60-2766-50**  
BARRAQUER

12,5 cm  
gerade, ohne Sperre, Maul 0,5 mm  
straight, without catch, jaw 0,5 mm  
droit, sans ressort, mors 0,5 mm  
recta, sin muelle, boca 0,5 mm

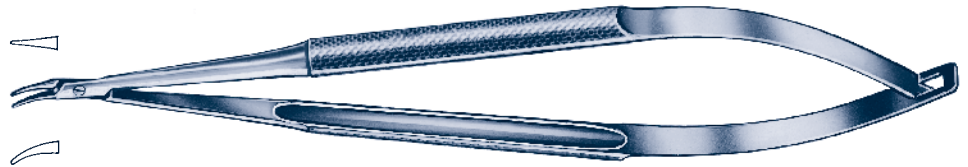

2767-50

**SA60-2767-50**  
BARRAQUER

12,5 cm  
gebogen, ohne Sperre, Maul 0,5 mm  
curved, without catch, jaw 0,5 mm  
courbe, sans ressort, mors 0,5 mm  
curva, sin muelle, boca 0,5 mm



**SA60-2768-50**  
BARRAQUER

12,5 cm  
gerade, mit Sperre, Maul 0,5 mm  
straight, with catch, jaw 0,5 mm  
droit, avec ressort, mors 0,5 mm  
recta, con muelle, boca 0,5 mm

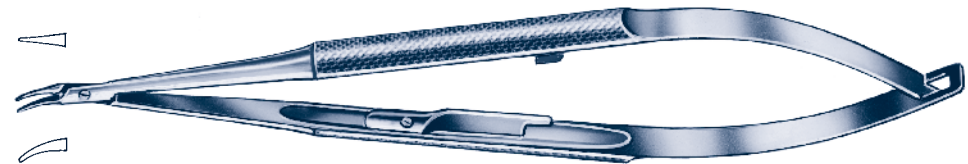

2769-50

**SA60-2769-50**  
BARRAQUER

12,5 cm  
gebogen, mit Sperre, Maul 0,5 mm  
curved, with catch, jaw 0,5 mm  
courbe, avec ressort, mors 0,5 mm  
curva, con muelle, boca 0,5 mm



**SA60-2773-06**

10,5 cm  
gebogen, Maul 0,60 mm  
curved, jaw 0,60 mm  
courbe, mors 0,60 mm  
curvo, boca 0,60 mm

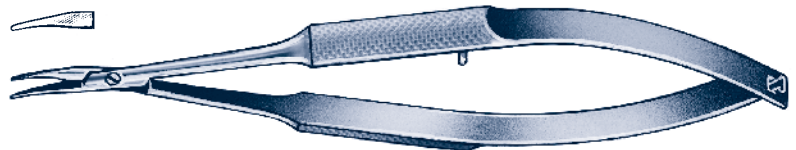

**SA60-2775-50**  
BARRAQUER

11,5 cm

gebogen, ohne Sperre, Maul 0,5 mm  
curved, without catch, jaw 0,5 mm  
courbe, sans ressort, mors 0,5 mm  
curva, sin muelle, boca 0,5 mm

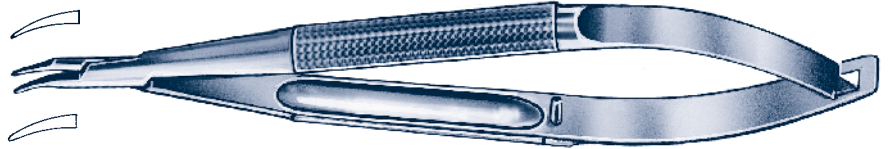

**SA60-2775-75**  
BARRAQUER

11,5 cm

gebogen, ohne Sperre, Maul 0,75 mm  
curved, without catch, jaw 0,75 mm  
courbe, sans ressort, mors 0,75 mm  
curva, sin muelle, boca 0,75 mm

**SA60-2777-75**  
BARRAQUER

11,5 cm

gebogen, mit Sperre, Maul 0,75 mm  
curved, with catch, jaw 0,75 mm  
courbe, avec ressort, mors 0,75 mm  
curva, con muelle, boca 0,75 mm

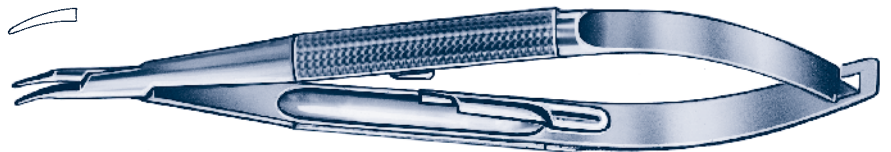

**SA60-2783-05**  
BARRAQUER

12,5 cm

stark gebogen, ohne Sperre, Maul 0,5 mm  
strong curved, without catch, jaw 0,5 mm  
très courbe, sans ressort, mors 0,5 mm  
muy curva, sin muelle, boca 0,5 mm

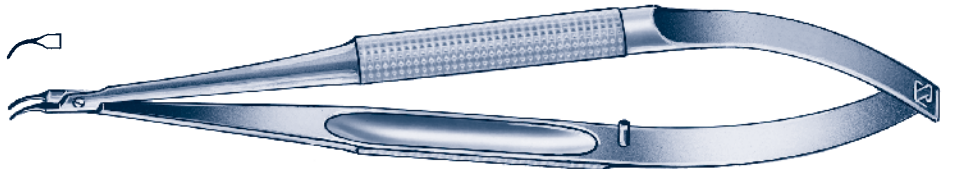

**SA60-2786-50**  
BARRAQUER

9,5 cm

gerade, ohne Sperre, Maul 0,5 mm  
straight, without catch, jaw 0,5 mm  
droit, sans ressort, mors 0,5 mm  
recta, sin muelle, boca 0,5 mm

**SA60-2787-50**  
BARRAQUER

9,5 cm

gebogen, ohne Sperre, Maul 0,5 mm  
curved, without catch, jaw 0,5 mm  
courbe, sans ressort, mors 0,5 mm  
curva, sin muelle, boca 0,5 mm

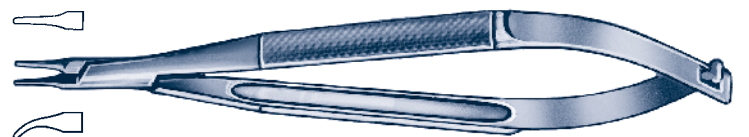

**SA60-2792-07**  
CASTROVIEJO

9,0 cm  
gerade, ohne Sperre, Maul 0,5 mm  
straight, without catch, jaw 0,5 mm  
droit, sans ressort, mors 0,5 mm  
recta, sin muelle, boca 0,5 mm

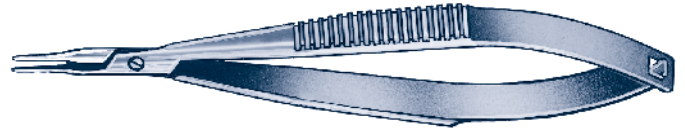

**SA60-2793-07**  
CASTROVIEJO

9,0 cm  
gebogen, ohne Sperre, Maul 0,5 mm  
curved, without catch, jaw 0,5 mm  
courbe, sans ressort, mors 0,5 mm  
curva, sin muelle, boca 0,5 mm

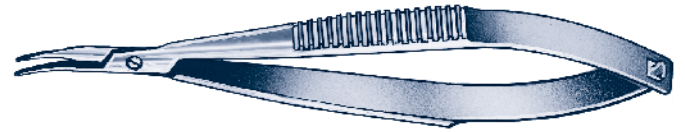

**SA60-2794-07**  
CASTROVIEJO

9,0 cm  
gerade, mit Sperre, Maul 0,5 mm  
straight, with catch, jaw 0,5 mm  
droit, avec ressort, mors 0,5 mm  
recta, con muelle, boca 0,5 mm

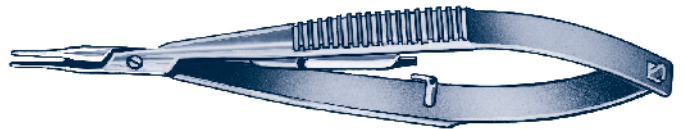

**SA60-2795-07**  
CASTROVIEJO

9,0 cm  
gebogen, mit Sperre, Maul 0,5 mm  
curved, with catch, jaw 0,5 mm  
courbe, avec ressort, mors 0,5 mm  
curva, con muelle, boca 0,5 mm

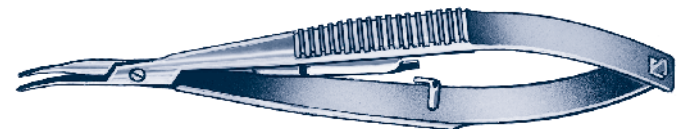

**SA60-2800-60**  
BARRAQUER

12 cm

gerade, ohne Sperre, Maul 0,5 mm  
straight, without catch, jaw 0,5 mm  
droit, sans ressort, mors 0,5 mm  
recta, sin muelle, boca 0,5 mm

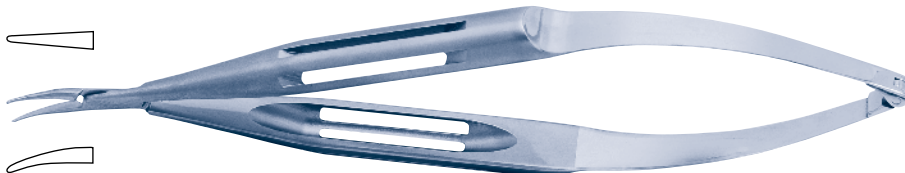

**SA60-2801-60**  
BARRAQUER

12 cm

gebogen, ohne Sperre, Maul 0,5 mm  
curved, without catch, jaw 0,5 mm  
courbe, sans ressort, mors 0,5 mm  
curva, sin muelle, boca 0,5 mm

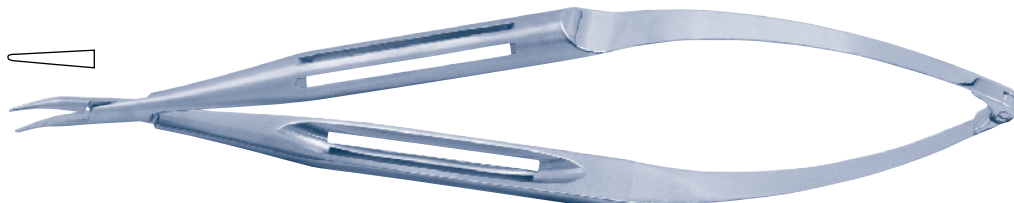

**SA60-2803-60**  
BARRAQUER

13,5 cm

gebogen, ohne Sperre, Maul 0,5 mm  
curved, without catch, jaw 0,5 mm  
courbe, sans ressort, mors 0,5 mm  
curva, sin muelle, boca 0,5 mm

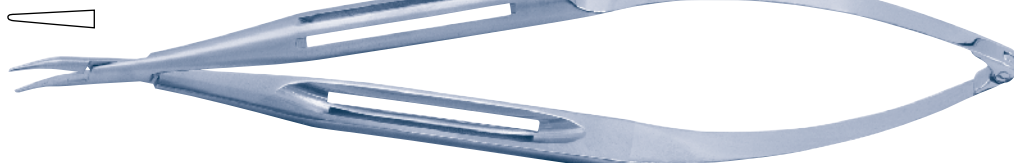

**SA60-2806-50**  
BARRAQUER

13,5 cm

gerade, ohne Sperre, Maul 0,5 mm  
straight, without catch, jaw 0,5 mm  
droit, sans ressort, mors 0,5 mm  
recta, sin muelle, boca 0,5 mm

**SA60-2807-50**  
BARRAQUER

13,5 cm

gebogen, ohne Sperre, Maul 0,5 mm  
curved, without catch, jaw 0,5 mm  
courbe, sans ressort, mors 0,5 mm  
curva, sin muelle, boca 0,5 mm

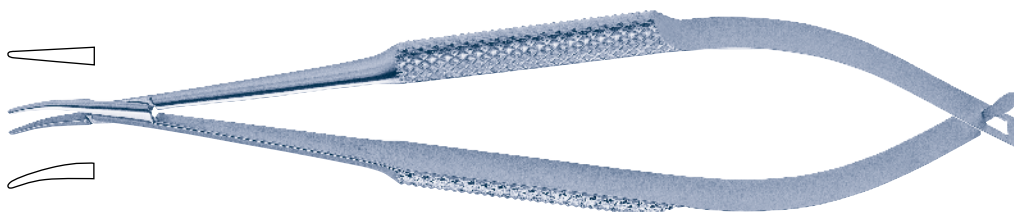

2809-10

**SA60-2809-10**  
BARRAQUER

13,5 cm

gebogen, ohne Sperre, Maul 1,0 mm  
curved, without catch, jaw 1,0 mm  
courbe, sans ressort, mors 1,0 mm  
curva, sin muelle, boca 1,0 mm

**SA60-2810-50**  
TROUTMAN

11 cm  
gerade, ohne Sperre, Maul 0,5 mm  
straight, without catch, jaw 0,5 mm  
droit, sans ressort, mors 0,5 mm  
recta, sin muelle, boca 0,5 mm

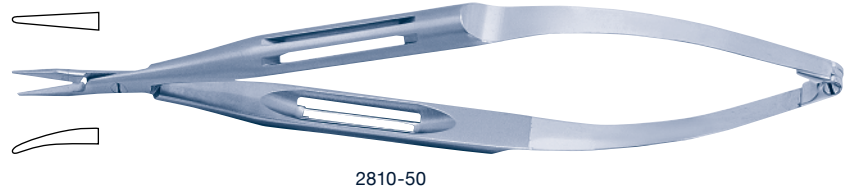

**SA60-2811-50**  
TROUTMAN

11 cm  
gebogen, ohne Sperre, Maul 0,5 mm  
curved, without catch, jaw 0,5 mm  
courbe, sans ressort, mors 0,5 mm  
curva, sin muelle, boca 0,5 mm

**SA60-2812-50**  
TROUTMAN

11 cm  
gerade, mit Sperre, Maul 0,5 mm  
straight, with catch, jaw 0,5 mm  
droit, avec ressort, mors 0,5 mm  
recta, con muelle, boca 0,5 mm

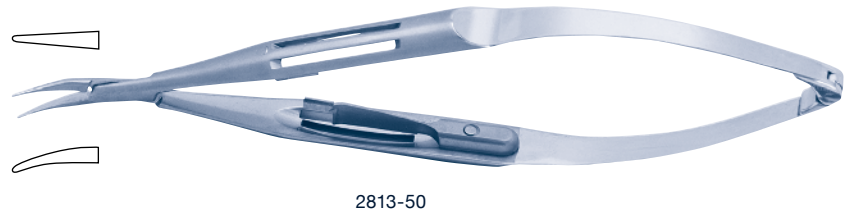

**SA60-2813-50**  
TROUTMAN

11 cm  
gebogen, mit Sperre, Maul 0,5 mm  
curved, with catch, jaw 0,5 mm  
courbe, avec ressort, mors 0,5 mm  
curva, con muelle, boca 0,5 mm

**SA60-2814-03**  
CASTROVIEJO-KOSHIMA

14,5 cm  
gerade, ohne Sperre, Maul 0,3 mm  
straight, without catch, jaw 0,3 mm  
droit, sans ressort, mors 0,3 mm  
recta, sin muelle, boca 0,3 mm

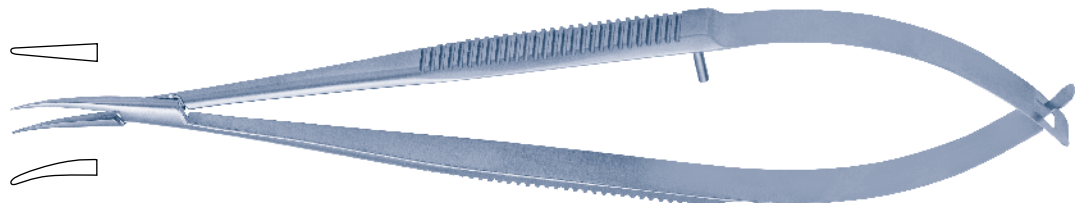

**SA60-2815-03**  
CASTROVIEJO-KOSHIMA

14,5 cm  
gebogen, ohne Sperre, Maul 0,3 mm  
curved, without catch, jaw 0,3 mm  
courbe, sans ressort, mors 0,3 mm  
curva, sin muelle, boca 0,3 mm

**SA60-2816-03**  
CASTROVIEJO-KOSHIMA

14,5 cm  
gerade, mit Sperre, Maul 0,3 mm  
straight, with catch, jaw 0,3 mm  
droit, avec ressort, mors 0,3 mm  
recta, con muelle, boca 0,3 mm

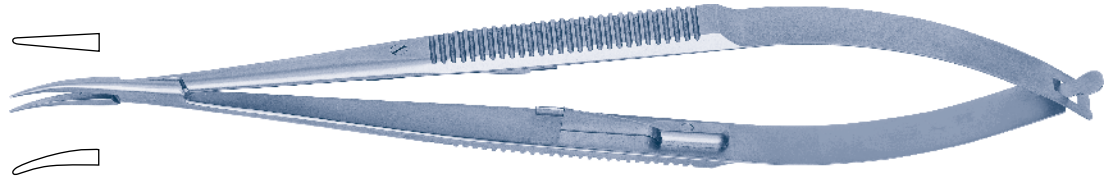

**SA60-2817-03**  
CASTROVIEJO-KOSHIMA

14,5 cm  
gebogen, mit Sperre, Maul 0,3 mm  
curved, with catch, jaw 0,3 mm  
courbe, avec ressort, mors 0,3 mm  
curva, con muelle, boca 0,3 mm

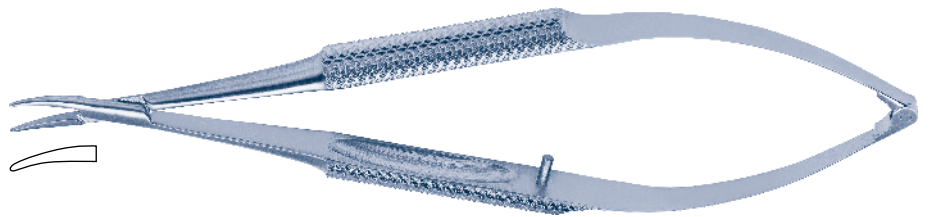

**SA60-2819-60**  
BARRAQUER

12 cm  
gebogen, ohne Sperre, Maul 0,6 mm  
curved, without catch, jaw 0,6 mm  
courbe, sans ressort, mors 0,6 mm  
curva, sin muelle, boca 0,6 mm



**SA60-2820-40**  
BARRAQUER

13,5 cm  
gerade, ohne Sperre, Maul 0,4 mm  
straight, without catch, jaw 0,4 mm  
droit, sans ressort, mors 0,4 mm  
recta, sin muelle, boca 0,4 mm

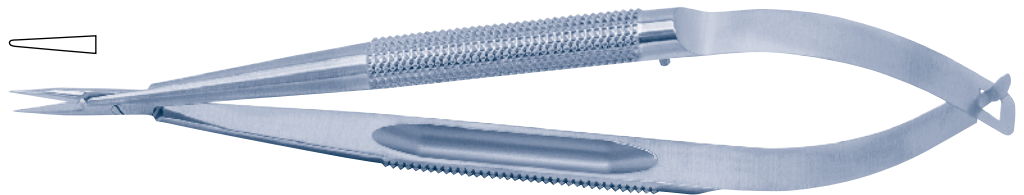

**SA60-2821-50**  
BARRAQUER

13,5 cm  
gebogen, ohne Sperre, Maul 0,5 mm  
curved, without catch, jaw 0,5 mm  
courbe, sans ressort, mors 0,5 mm  
curva, sin muelle, boca 0,5 mm

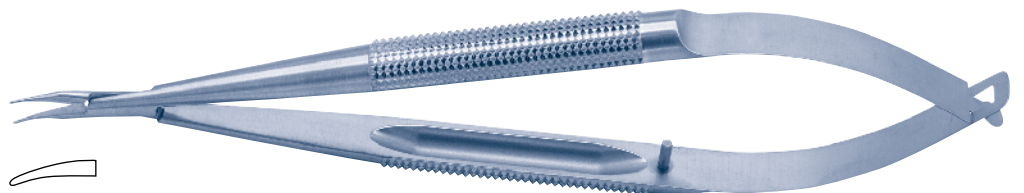

**SA60-2822-40**  
BARRAQUER

13,5 cm  
gerade, mit Sperre, Maul 0,4 mm  
straight, with catch, jaw 0,4 mm  
droit, avec ressort, mors 0,4 mm  
recta, con muelle, boca 0,4 mm

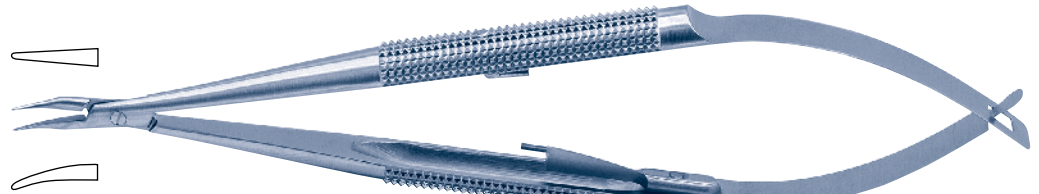

**SA60-2823-50**  
BARRAQUER

13,5 cm  
gebogen, mit Sperre, Maul 0,5 mm  
curved, with catch, jaw 0,5 mm  
courbe, avec ressort, mors 0,5 mm  
curva, con muelle, boca 0,5 mm

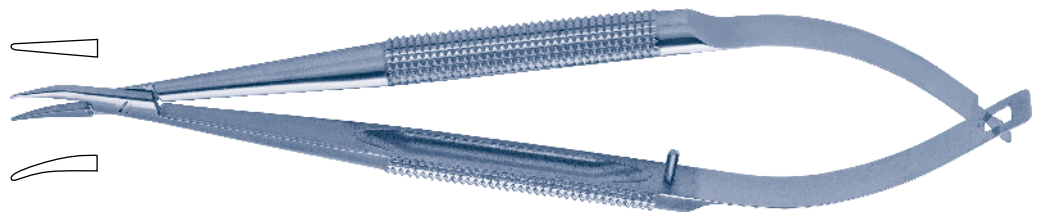

**SA60-2825-05**  
BARRAQUER

13,5 cm  
gebogen, ohne Sperre, Maul 0,5 mm  
curved, without catch, jaw 0,5 mm  
courbe, sans ressort, mors 0,5 mm  
curva, sin muelle, boca 0,5 mm

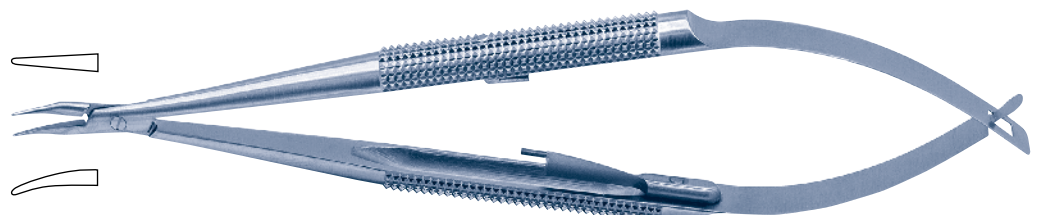

**SA60-2826-05**  
BARRAQUER

13,5 cm  
gerade, mit Sperre, Maul 0,5 mm  
straight, with catch, jaw 0,5 mm  
droit, avec ressort, mors 0,5 mm  
recta, con muelle, boca 0,5 mm

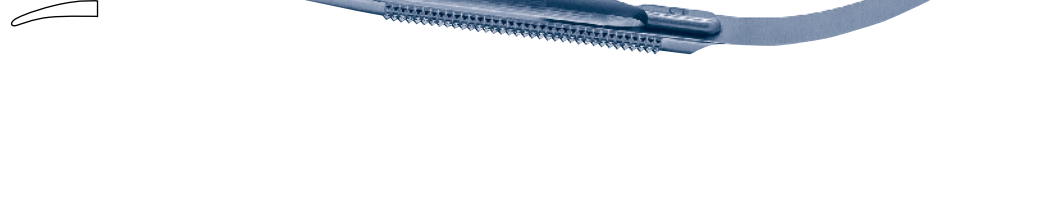

**SA60-2827-05**  
BARRAQUER

13,5 cm  
gebogen, mit Sperre, Maul 0,5 mm  
curved, with catch, jaw 0,5 mm  
courbe, avec ressort, mors 0,5 mm  
curva, con muelle, boca 0,5 mm

**SA60-2828-05**  
BARRAQUER

11,5 cm  
gerade, ohne Sperre, Maul 0,5 mm  
straight, without catch, jaw 0,5 mm  
droit, sans ressort, mors 0,5 mm  
recta, sin muelle, boca 0,5 mm

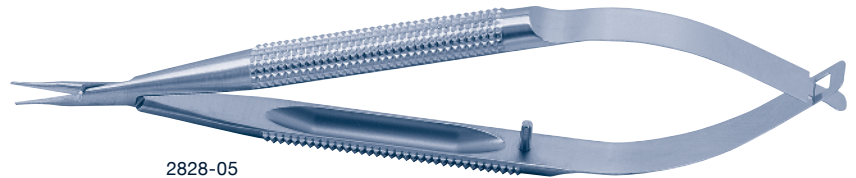

**SA60-2829-05**  
BARRAQUER

11,5 cm  
gebogen, ohne Sperre, Maul 0,5 mm  
curved, without catch, jaw 0,5 mm  
courbe, sans ressort, mors 0,5 mm  
curva, sin muelle, boca 0,5 mm

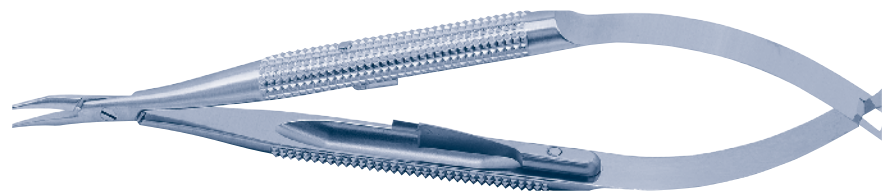

**SA60-2831-05**  
BARRAQUER

11,5 cm  
gebogen, mit Sperre, Maul 0,5 mm  
curved, with catch, jaw 0,5 mm  
courbe, avec ressort, mors 0,5 mm  
curva, con muelle, boca 0,5 mm

**SA60-2833-05**  
ANIS

11,5 cm  
gebogen, mit Sperre, Maul 0,5 mm  
curved, with catch, jaw 0,5 mm  
courbe, avec ressort, mors 0,5 mm  
curva, con muelle, boca 0,5 mm





**SA60-3500-00**  
**BARRAQUER**

11 cm

Klingenhalter  
Blade breaker and holder  
Porte-lame  
Porta-hoja

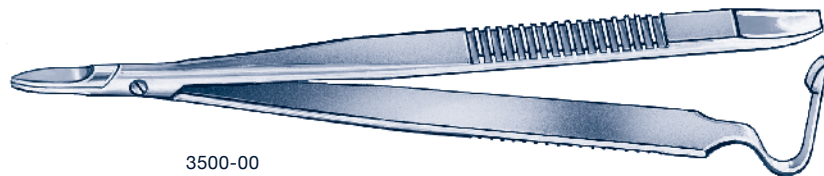

3500-00

**SA60-3500-01**  
**BARRAQUER**

11 cm

Klingenhalter, extra feines Maul  
Blade breaker and holder, extremely delicate jaws  
Porte-lame, mors ultra fine  
Porta-hoja, boca muy fina

**SA60-3504-06**  
**CASTROVIEJO**

12 cm

Klingenhalter  
Blade breaker and holder  
Porte-lame  
Porta-hoja



**SA60-3505-06**  
**CASTROVIEJO**

9 cm

Klingenhalter  
Blade breaker and holder  
Porte-lame  
Porta-hoja



**SA60-3506-07**

10 cm

Klingenhalter für Mikro-Klingen  
Blade holder for micro-blades  
Porte-lame pour micro-lames  
Porta-hoja para micro-hojas



**SA60-3507-06**  
**TROUTMAN**

9 cm

Klingenhalter  
Blade breaker and holder  
Porte-lame  
Porta-hoja



**SKALPELLGRIFF**  
**SCALPEL HANDLE**

**MANCHE DE SCALPEL**  
**MANGO DE BISTURÍ**

**SA60-3509-07**

7,5 cm

Skalpellgriff  
Chuck handle  
Manche de scalpel  
Mango de bisturí



3509-07

**SA60-3509-10**

10 cm

Skalpellgriff  
Chuck handle  
Manche de scalpel  
Mango de bisturí

**SA60-3525-03**

Skalpellgriff Nr. 3  
Scalpel-handle No. 3  
Manche de scalpel No. 3  
Mango de bisturí No. 3

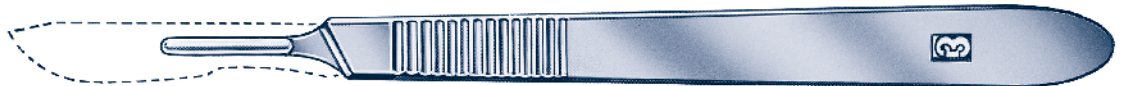

**SA60-3525-7K**

Skalpellgriff Nr. 7K  
Scalpel-handle No.7K  
Manche de scalpel No. 7K  
Mango de bisturí No. 7K



**SA60-3525-09**

Skalpellgriff Nr. 9  
Scalpel-handle No.9  
Manche de scalpel No. 9  
Mango de bisturí No. 9



Andere Modelle auf Wunsch erhältlich  
Other models available  
Autres modèles sur demande  
Otros modelos, sobre demanda

LUER-KONUS

LUER-LOCK

**SA60-3600-30** 30 Gauge / 0,30 mm Ø  
**SA60-3600-40** 27 Gauge / 0,40 mm Ø  
**SA60-3600-50** 25 Gauge / 0,50 mm Ø



gerade, stumpfe Spitze  
 straight, blunt tip  
 droite, mousse  
 recta, punta roma

**SA60-3602-30** 30 Gauge / 0,30 mm Ø  
**SA60-3602-40** 27 Gauge / 0,40 mm Ø



gewinkelt, stumpfe Spitze  
 angled, blunt tip  
 coudée, mousse  
 angulosa, punta roma

**SA60-3603-30** 30 Gauge / 0,30 mm Ø  
**SA60-3603-40** 27 Gauge / 0,40 mm Ø



gebogen, stumpfe Spitze  
 curved, blunt tip  
 courbe, mousse  
 curva, punta roma

**SA60-3604-23** 23 Gauge / 0,65 mm Ø  
**SA60-3604-27** 27 Gauge / 0,40 mm Ø  
**SA60-3604-30** 30 Gauge / 0,30 mm Ø  
 Ø RAININ

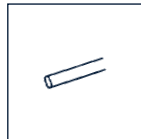

Luftkanüle, spatelförmige Spitze  
 Air injection cannula, spatulated tip  
 Canule pour injection d'air, pointe aplatie  
 Cánula para aire, punta Espátula

**SA60-3605-22** 22 Gauge / 0,70 mm Ø  
 HEALON

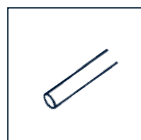

Injektionskanüle, gewinkelt  
 Injection cannula, angled  
 Canule pour injection, coudée  
 Cánula para inyección, angulada

**SA60-3606-26** 26 Gauge / 0,45 mm Ø  
**SA60-3606-27** 27 Gauge / 0,40 mm Ø  
 SAUTTER



Luftkanüle, gebogen  
 Air injection cannula, curved  
 Canule pour injection d'air, courbe  
 Cánula para aire, curva

**SA60-3609-70** 22 Gauge / 0,70 mm Ø  
 ANEL



Traenenwegkanüle, leicht gebogen  
 Lacrimal cannula, slightly curved  
 Canule a voies lacrymales, courbe moyen  
 Cánula lacrimal, media curva

**SA60-3610-70** 22 Gauge / 0,70 mm Ø  
 ANEL



Traenenwegkanüle, gerade  
 Lacrimal cannula, straight  
 Canule a voies lacrymales, droit  
 Cánula lacrimal, recta

LUER-KONUS

LUER-LOCK

**SA60-3611-70** 22 Gauge / 0,70 mm Ø  
ANEL



Tränenwegkanüle, gebogen  
Lacrimal cannula, curved  
Canule a voies lacrymales, courbe  
Cánula lacrimal, muy curva

**SA60-3612-21** 21 Gauge / 0,80 mm Ø  
BRAUWEILER

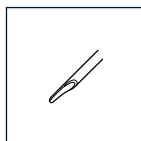

Spülkanüle, gewinkelt  
Irrigating cannula, angled  
Canule irrigatoire, coudée  
Cánula para irrigación,angulada

**SA60-3613-19** 19 Gauge / 1,00 mm Ø  
**SA60-3613-20** 20 Gauge / 0,90 mm Ø  
BONN

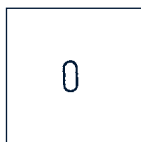

Spülkanüle, gewinkelt  
Irrigating cannula, angled  
Canule irrigatoire, coudée  
Cánula para irrigación,angulada

**SA60-3614-10** Olive 1,1 mm Ø



**SA60-3615-10** Olive 1,1 mm Ø  
**SA60-3615-23** Olive 1,3 mm Ø



**SA60-3616-25** Olive 1,2 mm Ø  
TROUTMAN



Alpha-Chymotrypsin Kanüle  
Alpha-Chymotrypsin cannula  
Alpha-Chymotrypsin canule  
Alpha-Chymotrypsin cánula

**SA60-3617-46** 40 x 0,6 mm Ø  
ATKINSON

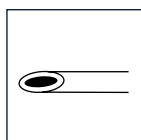

Retrobulbäre Kanüle  
Retrobulbar cannula  
Canule retrobulbaire  
Cánula retrobulbar

LUER-KONUS

LUER-LOCK

**SA60-3619-19** 19 Gauge/sub tenon  
STEVENS



Anästhesie Kanüle  
Anesthesia cannula  
Canule pour anesthésie  
Cánula para anestesia

**SA60-3621-15** 15 mm  
CASTROVIEJO



Kanüle zur Cyklodialyse  
Cycloablation cannula  
Canule pour cycloablation  
Cánula para ciclodialisis

**SA60-3623-19**  
RANDOLPH

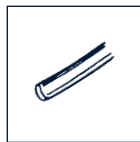

Kanüle zur Cyklodialyse  
Cycloablation cannula  
Canule pour cycloablation  
Cánula para ciclodialisis

**SA60-3626-19**  
SHEETS



Kanüle zur Cyklodialyse  
Cycloablation cannula  
Canule pour cycloablation  
Cánula para ciclodialisis

**SA60-3627-26** 26 Gauge



Kanüle zur Cyklodialyse  
Cycloablation cannula  
Canule pour cycloablation  
Cánula para ciclodialisis

**SA60-3630-30**  
SHEPARD

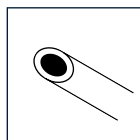

Spülkanüle für radiale Keratotomie  
Radial keratotomy irrigation cannula  
Canule irrigatoire pour kératotomie radiale  
Cánula de irrigación para queratotomia radial

**SA60-3632-23**



Tränenwegkanüle, gerade, konisch V2A-Stahl  
Lacrimal cannula, straight, stainless steel  
Canule à voies lacrymales, droite, inox  
Cánula lacrimal, recta, inox

LUER-KONUS

LUER-LOCK

SA60-3633-23

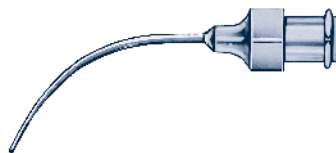

Tränenwegkanüle, gebogen, konisch V2A-Stahl  
Lacrimal cannula, curved, stainless steel  
Canule à voies lacrymales, courbee, inox  
Cánula lacrimal, curva, inox

SA60-3634-23



Tränenwegkanüle, kurz gewinkelt, konisch V2A-Stahl  
Lacrimal cannula, short angled, stainless steel  
Canule à voies lacrymales, coudee, inox  
Cánula lacrimal, angulada, inox

SA60-3635-23

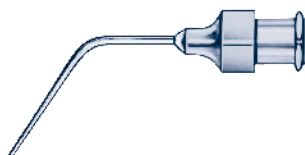

Tränenwegkanüle, lang gewinkelt, konisch V2A-Stahl  
Lacrimal cannula, long angled, stainless steel  
Canule à voies lacrymales, coudee, inox  
Cánula lacrimal, angulada, inox

SA60-3639-23 26 Gauge

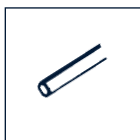

Spülcystotomkanüle  
Irrigation cystotome cannula  
Canule irrigatoire pour cystotome  
Cánula de irrigación para cistotomo

SA60-3640-23 23 Gauge  
SA60-3640-26 26 Gauge  
SA60-3640-30 30 Gauge

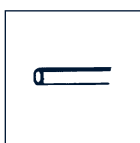

Vorderkammer-Spülkanüle, gerade  
Anterior chamber irrigation cannula, straight  
Canule irrigatoire pour la chambre antérieure, droite  
Cánula de irrigación para cámara anterior, recta

SA60-3641-23 23 Gauge  
SA60-3641-26 26 Gauge  
SA60-3641-30 30 Gauge

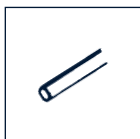

Vorderkammer-Spülkanüle, gewinkelt  
Anterior chamber irrigation cannula, angled  
Canule irrigatoire pour la chambre antérieure, coudee  
Cánula de irrigación para cámara anterior, angulada

SA60-3647-25 25 Gauge

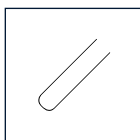

Hydrodissektionskanüle  
Hydrodissection cannula  
Canule pour hydrodissection  
Cánula de hidrodissección

LUER-KONUS

LUER-LOCK

**SA60-3648-23**  
McINTYRE



Tränenwegkanüle, mit 2 seitlichen Öffnungen  
0,30 mm, gerade  
Lacrimal cannula, 2 side openings 0,30 mm, straight  
Canule à voies lacrymales, 2 orifices latéral  
0,30 mm, droite  
Cánula lacrimal, con 2 aberturas laterales de  
0,30 mm, recta

**SA60-3649-23**  
McINTYRE



Tränenwegkanüle, mit 2 seitlichen Öffnungen  
0,30 mm, gebogen  
Lacrimal cannula, 2 side openings 0,30 mm, curved  
Canule à voies lacrymales, 2 orifices latéral  
0,30 mm, courbe  
Cánula lacrimal, con 2 aberturas laterales de  
0,30 mm, curva

**SA60-3650-20** 20 Gauge  
**SA60-3650-23** 23 Gauge  
WEST

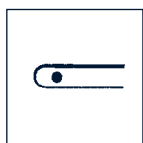

Spülkanüle, seitliche Öffnung 0,30 mm  
Irrigation cannula, side opening 0,30 mm  
Canule irrigatoire, orifice latéral, 0,30 mm  
Cánula para irrigación, abertura lateral 0,30 mm

**SA60-3652-46** 40 x 0,6 mm Ø  
**SA60-3652-48** 40 x 0,8 mm Ø  
**SA60-3652-66** 60 x 0,6 mm Ø  
**SA60-3652-68** 60 x 0,8 mm Ø  
**SA60-3652-69** 60 x 0,9 mm Ø  
BANGERTER

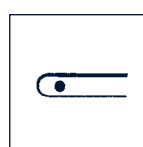

Sondenkanüle  
Probe cannula  
Canule-sonde  
Cánula tipo sonda

**SA60-3654-23** 13 mm  
**SA60-3655-23** 21 mm  
SIMCOE



Kortex-Extractor  
Cortex extractor  
Extracteur de cortex  
Extractor para corteza

**SA60-3657-19** 19 Gauge



Kanüle  
Cannula  
Canule  
Cánula

**SA60-3658-25** 2,5 mm lang  
**SA60-3658-40** 4,0 mm lang  
**SA60-3658-50** 5,0 mm lang  
**SA60-3658-60** 6,0 mm lang

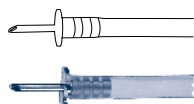

Infusionskanüle  
Infusion cannula  
Canule de perfusion  
Cánula para infusión

LUER-KONUS

LUER-LOCK

**SA60-3660-23  
HESLIN**

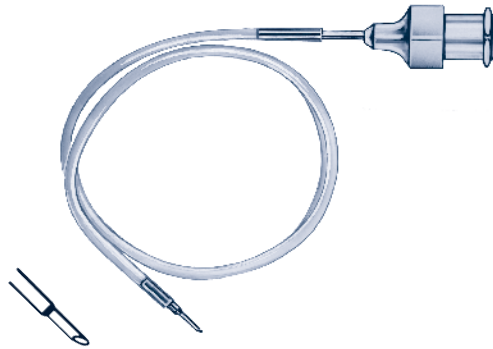

Infusionskanüle  
Infusion cannula  
Canule de perfusion  
Cánula para infusión

**SA60-3662-23  
SIMCOE**

Original-Modell  
Original model  
Modèle original  
Modelo original

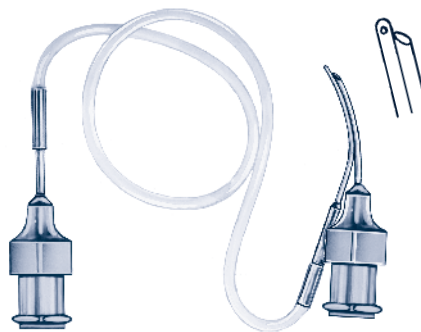

Kanüle  
Cannula  
Canule  
Cánula

**SA60-3663-23**

vertauschte Anschlüsse  
reversed tubes  
inversée  
reves

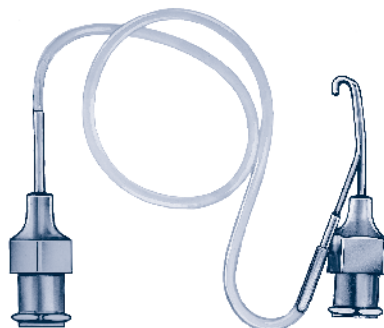

**SA60-3664-01  
SIMCOE**

Kanüle, rechts  
Cannula, right  
Canule, droite  
Cánula, derecha

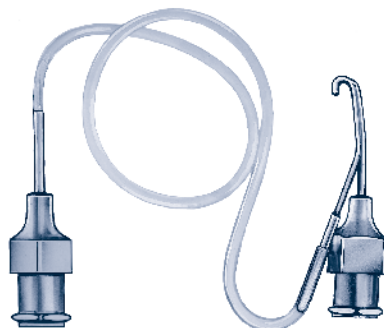

Kanüle, rechts  
Cannula, right  
Canule, droite  
Cánula, derecha

**SA60-3664-02  
SIMCOE**

Kanüle, links  
Cannula, left  
Canule, gauche  
Cánula, izquierda

SA60-3664-01

LUER-KONUS

LUER-LOCK

**SA60-3665-23** 23 Gauge  
**SA60-3665-27** 27 Gauge  
**SA60-3665-30** 30 Gauge  
KNOLLE



Vorderkammer-Spülkanüle  
Anterior chamber irrigating cannula  
Canule irrigatoire pour la chambre antérieure  
Cánula para irrigación para la cámara anterior

**SA60-3670-23**  
23 Gauge 4 Ports  
KNOLLE-PEARCE

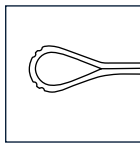

Linsenschlinge mit Spülung  
Irrigating vectis cannula  
Anse à lentilles avec irrigation  
Asa para lentes irrigación

**SA60-3671-20**  
20 Gauge 3 Ports  
SHEETS

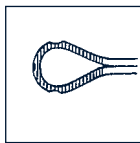

Linsenschlinge mit Spülung  
Irrigating vectis cannula  
Anse à lentilles avec irrigation  
Asa para lentes irrigación

**SA60-3686-19** 19 Gauge

**BISHOP-HARMON**

Vorderkammer-Spülkanüle  
Anterior chamber irrigation cannula  
Canule irrigatoire pour la chambre antérieure  
Cánula para irrigación para la cámara anterior

**SA60-3686-50**

Silikon Ball  
Silicone bulb  
Bulbe silicone  
Balón de silicon

**SA60-3686-60**

Luer Lock Adapter  
Adaptor  
Adapteur  
Adaptor

**SA60-3686-99**

Vorderkammerspülset  
Anterior chamber irrigating set  
Set pour irrigation la chambre antérieure  
Set de irrigador para la cámara anterior

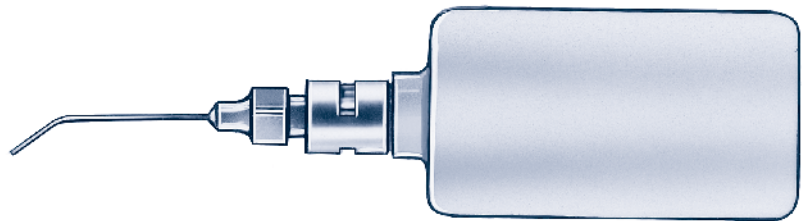

**SA60-3688-00**

**McINTYRE**

Spülhandgriff, männliche Anschlüsse  
Infusion handle, male connectors  
Manche irrigation, m-connecteur  
Mango para irrigación, conexiones Luer



**SA60-3689-00**

**KANSAS**

Spülhandgriff  
Infusion handle  
Manche irrigation  
Mango para irrigación



**SA60-3693-21** 21 Gauge

**BRAUWEILER**

Spülhandgriff, Spüloeffnung 2 x 0,50 mm, Spitze  
konisch, aufgerauht  
Irrigation handpiece, irrigation port 2 x 0,50 mm,  
conical tip, rough  
Manche d'irrigation, irrigation 2 x 0,50 mm, pointe  
conique, rugueux  
Mango de irrigación, abertura de irrigación  
2 x 0,50 mm, punta conica y arenosa



**SA60-3700-00**

160 x 85 mm

rostsicher  
stainless steel  
inox

**SA60-3710-00**

160 x 85 mm

Silikonersatz für 10 Heftinstrumente,  
passend in Etui 3700-00.  
Silicone tray for 10 cutting instruments,  
fitting into box 3700-00.

Boîte de silicone avec chevalet pour 10 instruments  
tranchants, s'adaptant dans l'etui 3700-00.  
Bandeja de silicona para 10 instrumentos cortantes,  
ajustandose en el estuche 3700-00.

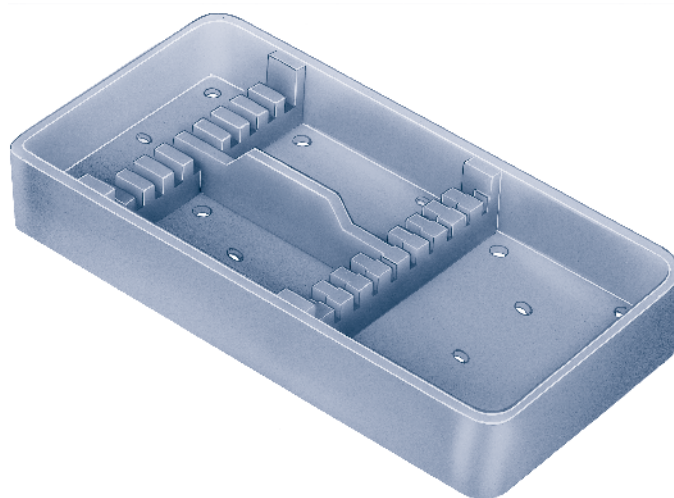
**SA60-3715-12**

Kanülenbänkchen für 12 Kanülen  
Silicone tray for 12 cannulas  
Boîte de silicone pour 12 canules  
Bandeja de silicona para 12 canulas

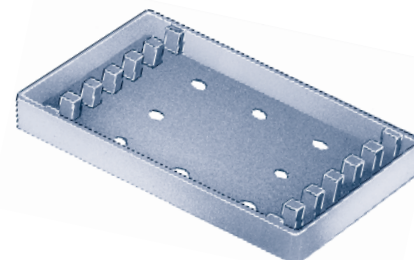

**SA60-3720-00**

300 x 600 mm

Silikon-Noppenmatte

Silicone-mat

Tapis en silicone

Alfombrilla de silicona

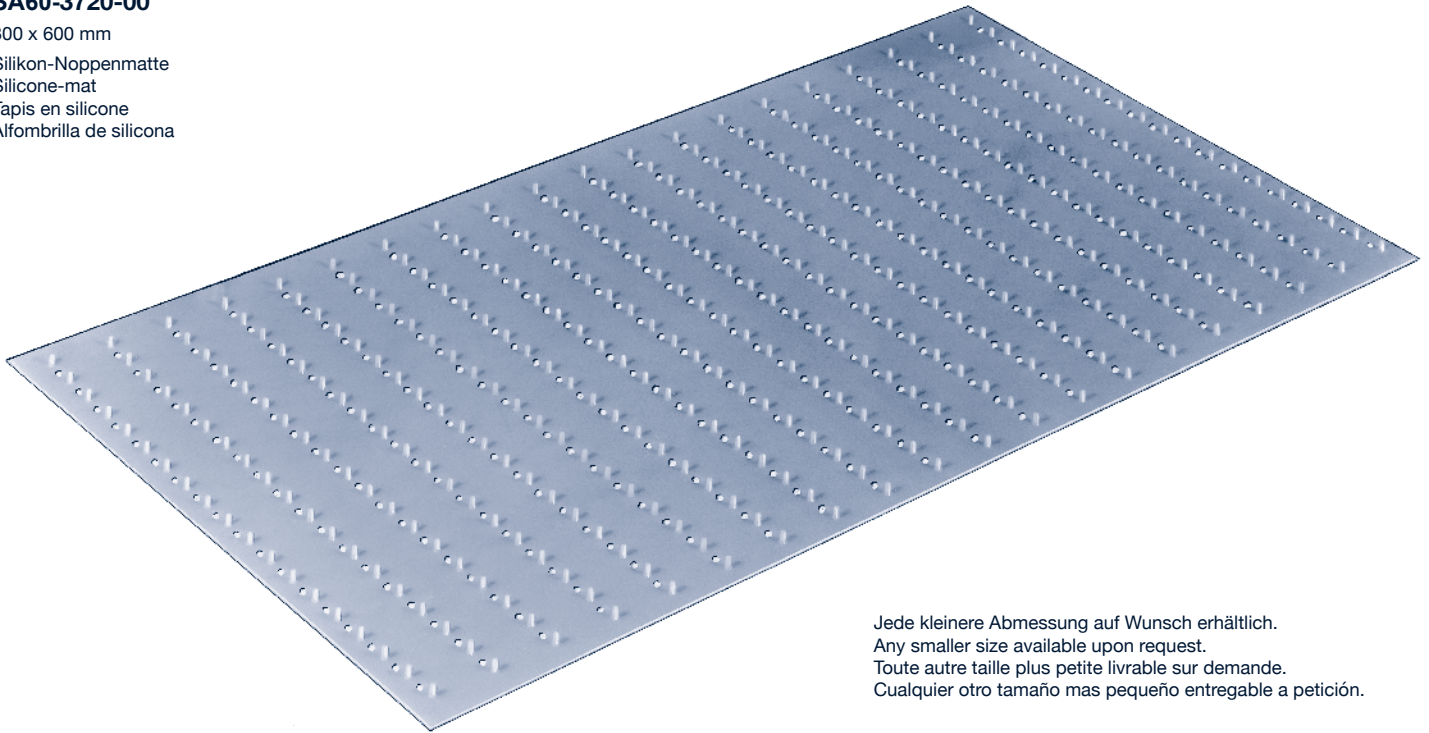

Jede kleinere Abmessung auf Wunsch erhältlich.

Any smaller size available upon request.

Toute autre taille plus petite livrable sur demande.

Cualquier otro tamaño mas pequeño entregable a petición.

**SA60-3720-01**

160 x 85 mm

Silikon-Noppenmatte, passend in Etui 3700-00

Silicone-mat, fits into box 3700-00

Tapis en silicone, pour boîte 3700-00

Alfombrilla de silicona, para caja 3700-00

**SA60-3725-46**

460 x 30 mm

Silikon-Noppenstreifen

Silicone bar

Tapis en silicone

Alfombrilla de silicona

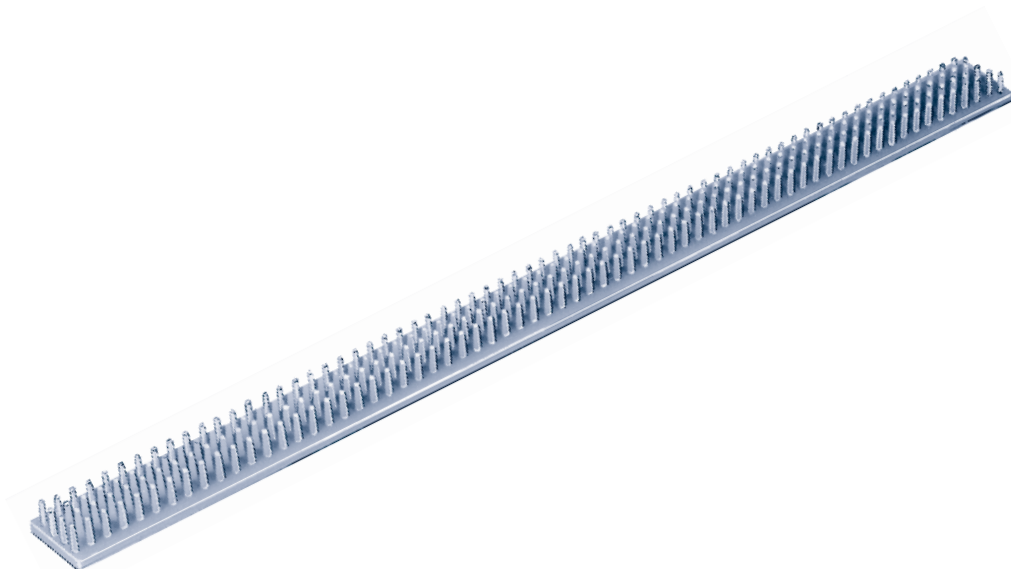

Sterilisierbehälter aus Edelstahl mit Noppenmatten  
 Stainless steel sterilization cases with silicone mats  
 Boîtes de stérilisation inox avec support silicone  
 Cajas para esterilizar inox con bandejas de silicona

<b>SA60-3741-50</b>	200 x 140 x 45 mm
<b>SA60-3744-50</b>	280 x 195 x 45 mm
<b>SA60-3745-50</b>	265 x 255 x 45 mm
<b>SA60-3746-50</b>	370 x 190 x 45 mm
<b>SA60-3747-50</b>	380 x 260 x 45 mm

Einlagig  
 1 layer  
 1 étage  
 1 capa

<b>SA60-3741-65</b>	200 x 140 x 65 mm
<b>SA60-3744-65</b>	280 x 195 x 65 mm
<b>SA60-3745-65</b>	265 x 255 x 65 mm
<b>SA60-3746-65</b>	370 x 190 x 65 mm
<b>SA60-3747-65</b>	380 x 260 x 65 mm

Zweilagig  
 2 layers  
 2 étages  
 2 capas



Container mit Edelstahlsiebkorb, Silikonmatte und Silikonhalterungen  
 Container with stainless steel baskets, silicone mat and silicone fixation  
 Boîte de stérilisation avec boîte en inox et supporte silicone  
 Caja para esterilizar con bandeja-tamize et bandeja de silicona

	Außenmaße Outer dimensions Dimension extérieure Dimensiones exteriores	Edelstahlsiebkorb stainless steel basket boîte en inox bandeja-tamize
<b>CS3741-50</b>	227 x 166 x 60 mm	186 x 150 x 35 mm
<b>CS3744-50</b>	312 x 189 x 66 mm	270 x 175 x 35 mm
<b>CS3745-50</b>	299 x 278 x 105 mm	250 x 240 x 32 mm
<b>CS3747-50</b>	462 x 278 x 105 mm	403 x 250 x 32 mm

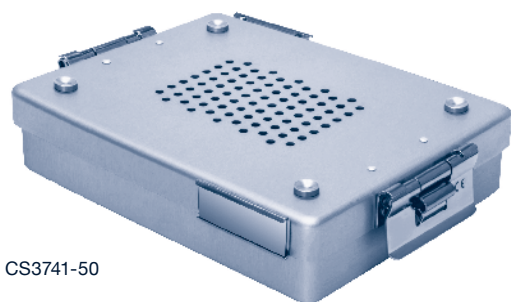

CS3741-50



CS3747-50

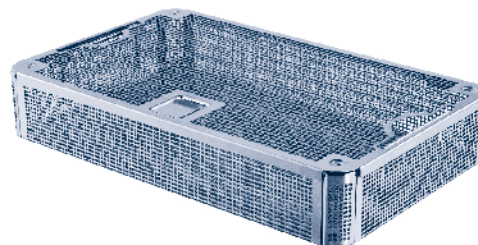
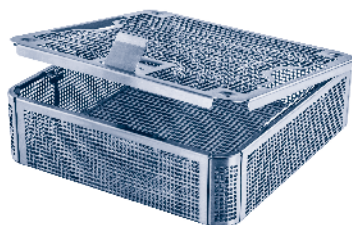

Container mit zwei Edelstahlsiebkörben, Silikonmatte und Silikonhalterungen  
 Container with two stainless steel baskets, silicone mat and silicone fixation  
 Boîte de stérilisation avec deux boîtes en inox et supporte silicone  
 Caja para esterilizar con dos bandejas-tamizes et bandeja de silicona

	Außenmaße Outer dimensions Dimension extérieure Dimensiones exteriores	Edelstahlsiebkorb (2x) stainless steel basket (2x) boîte en inox (2x) bandeja-tamize (2x)
<b>CD3741-65</b>	227 x 166 x 100 mm	186 x 150 x 35 mm
<b>CD3744-65</b>	312 x 189 x 83 mm	270 x 175 x 35 mm
<b>CD3745-65</b>	299 x 278 x 105 mm	250 x 240 x 32 mm
<b>CD3747-65</b>	462 x 278 x 105 mm	403 x 250 x 32 mm

**SA60-3760-04**  
**SA60-3760-06**  
**SA60-3760-11**

Ø 41 x 19 mm  
Ø 61 x 30 mm  
Ø 116 x 35 mm

Nirosta  
Stainless steel  
Acier inoxydable  
Acero inoxidable



# IRIDEKTOMIESCHEREN

## IRIS SCISSORS

# CISEAUX À IRIDECTOMIE

## TIJERAS PARA IRIDECTOMIA



**SA60-400\$-41**

**SA60-400\$-42**

**SA60-400\$-43**

10,0 cm  
gerade  
straight  
droit  
recto

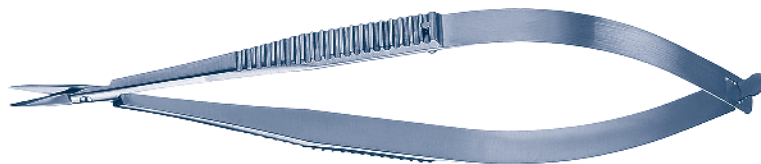

**SA60-4001-41**

**SA60-4001-42**

**SA60-4001-43**

10,0 cm  
gebogen  
curved  
courbe  
curvo

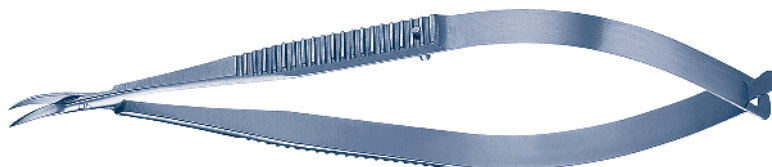

**SA60-4006-41**

**SA60-4006-42**

**SA60-4006-43**

11,0 cm  
gerade  
straight  
droit  
recto

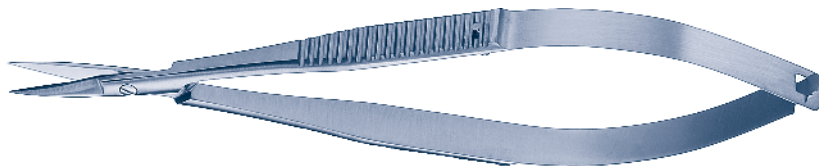

**SA60-4007-41**

**SA60-4007-42**

**SA60-4007-43**

11,0 cm  
gebogen  
curved  
courbe  
curvo

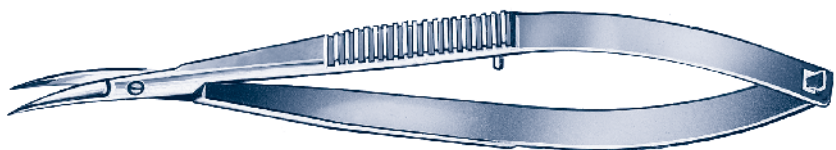



**SA60-4009-41 SA60-4009-43 SA60-4009-51**

11,0 cm  
gebogen  
curved  
courbe  
curvo

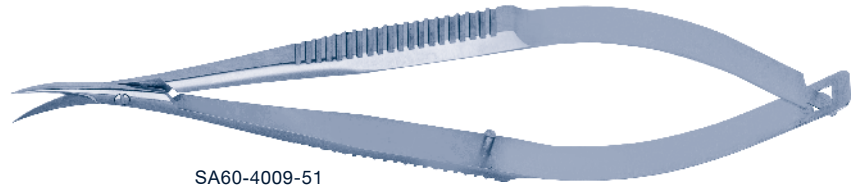

SA60-4009-51



**SA60-4010-41 SA60-4010-42 SA60-4010-43**

NOYES  
11,5 cm  
gerade  
straight  
droit  
recto

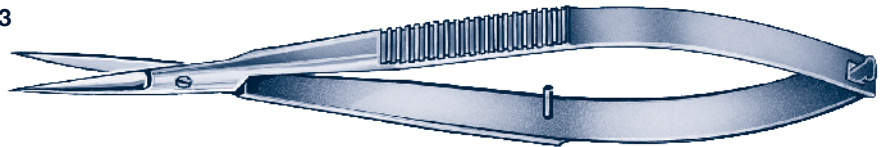

**SA60-4011-41 SA60-4011-42 SA60-4011-43**

NOYES  
11,5 cm  
gebogen  
curved  
courbe  
curvo

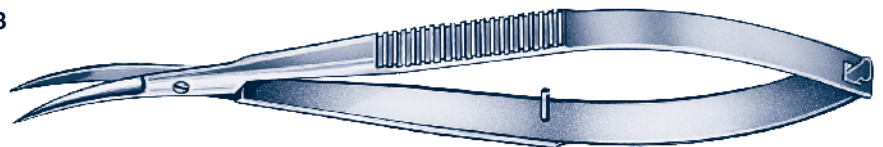

**SA60-14007-41**

12 cm  
gebogen  
curved  
courbe  
curvo

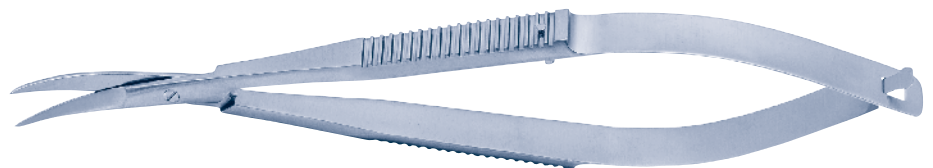

SA60-4021-08



SA60-4022-08



SA60-4023-08



4SA60-024-08  
WECKER

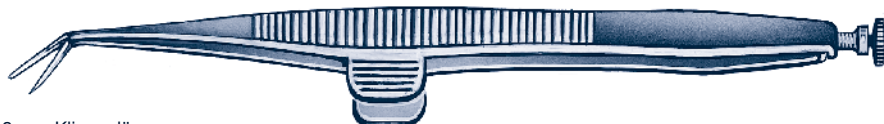

8 mm Klingenlänge  
8 mm length of cutting blades  
8 mm longueur des lames  
8 mm largo de las hojas

SA60-4021-12



4SA60-022-12



SA60-4023-12



SA60-4024-12  
WECKER



12 mm Klingenlänge  
12 mm length of cutting blades  
12 mm longueur des lames  
12 mm largo de las hojas



SA60-4030-07  
BARRAQUER

7 mm (normal)



SA60-4033-07

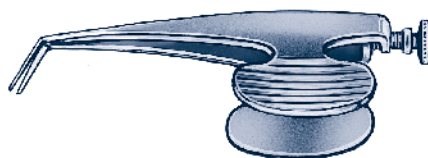

7 mm Klingenlänge  
7 mm length of cutting blades  
7 mm longueur des lames  
7 mm largo de las hojas



SA60-4030-10  
BARRAQUER

10 mm



SA60-4033-10

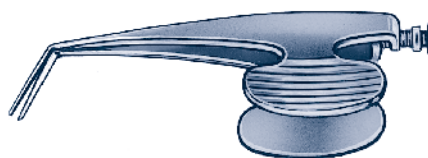

10 mm Klingenlänge  
10 mm length of cutting blades  
10 mm longueur des lames  
10 mm largo de las hojas

Normale Größe – Regular size – Taille normal – Tamaño normal

**SA60-4040-41**

VANNAS

8,5 cm

gerade, 7 mm Blattlänge  
straight, 7 mm blades  
droit, lames 7 mm  
recto, hojas 7 mm de largo



**SA60-4041-41**

VANNAS

8,5 cm

gebogen, Blattlänge  
7 mm curved, 7 mm blades  
courbe, lames 7 mm  
curvo, hojas 7 mm de largo

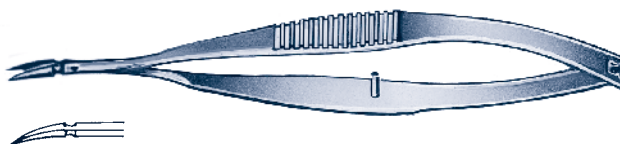

**SA60-4042-41**

VANNAS

8,5 cm

leicht aufgewinkelt  
slightly angled on flat  
légèrement angulaire  
ligeramente angulado

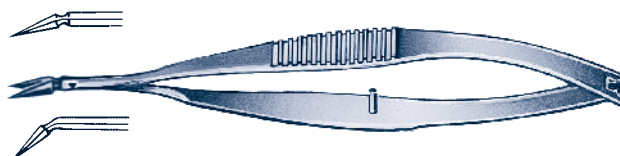

**SA60-4043-41**

VANNAS

8,5 cm

stark aufgewinkelt  
strong angled on flat  
très angulaire  
muy angulado



**SA60-4044-41**

VANNAS

8,0 cm

kniegebogen  
angled to side  
coudé  
angulado



Extra fein – Extremely delicate – Extra fine – Delicadísima

**SA60-4046-41**  
VANNAS

8,5 cm  
gerade, 5 mm Blattlänge  
straight, 5 mm blades  
droit, lames 5 mm  
recto, hojas 5 mm de largo

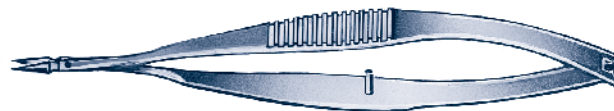

**SA60-4047-41**  
VANNAS

8,5 cm  
gebogen, Blattlänge 5 mm  
curved, 5 mm blades  
courbe, lames 5 mm  
curvo, hojas 5 mm de largo

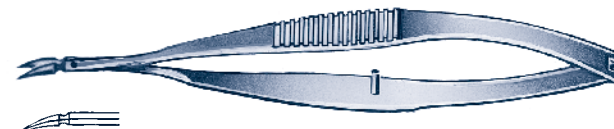

**SA60-4048-41**  
VANNAS

8 cm  
kniegebogen  
angled to side  
coudé  
angulado



**SA60-4049-41**  
VANNAS

8,5 cm  
leicht aufgewinkelt  
slightly angled on flat  
légèrement angulaire  
ligeramente angulado

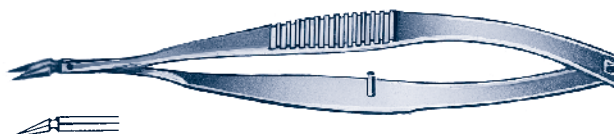

**SA60-4050-41**

MODELL TUEBINGEN

9 cm

gerade, Blattlänge 8 mm  
straight, 8 mm blades  
droit, lames 8 mm  
recto, hojas 8 mm de largo



**SA60-4051-41**

MODELL TUEBINGEN

9 cm

gebogen, Blattlänge 8 mm  
curved, 8 mm blades  
courbe, lames 8 mm  
curvo, hojas 8 mm de largo



**SA60-4053-41**

MODELL TUEBINGEN

8,5 cm

stark gebogen, Blattlänge 9 mm  
strong curved, 9 mm blades  
très courbe, lames 9 mm  
muy curvo, hojas 9 mm de largo



**SA60-4052-41**

GILL

8,5 cm

aufgewinkelt  
angled on flat  
angulaire  
angulado

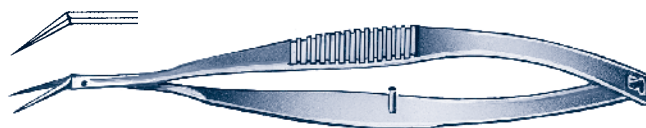

**SA60-6281-41**

GILLS-WELSH

8,5 cm

aufgewinkelt  
angled on flat  
angulaire  
angulado



**SA60-4060-61**

CASTROVIEJO-VANNAS

12 cm

gerade, Blattlänge 6 mm  
straight, 6 mm blades  
droit, lames 6 mm  
recto, hojas 6 mm de largo

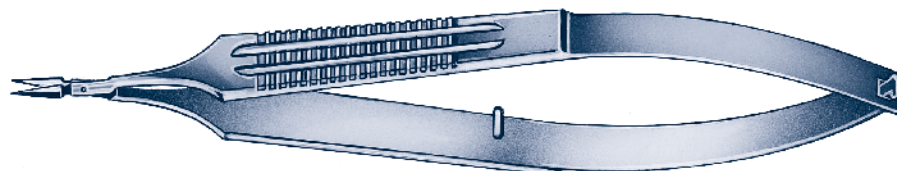

**SA60-4061-61**

CASTROVIEJO-VANNAS

12 cm

gebogen, Blattlänge 6 mm  
curved, 6 mm blades  
courbe, lames 6 mm  
curvo, hojas 6 mm de largo

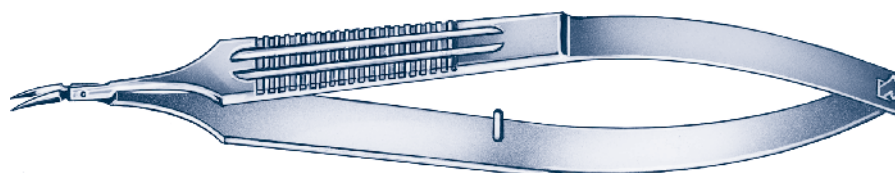

**SA60-9835-61**

VANNAS

12,5 cm  
gebogen  
curved  
courbe  
curvo

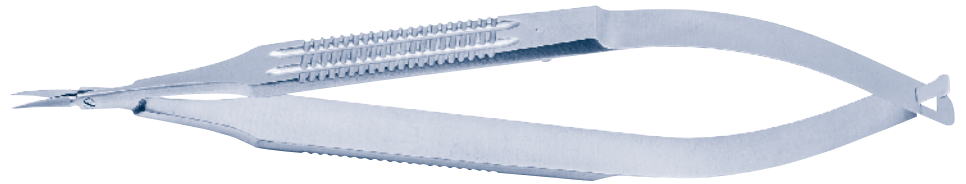

**SA60-4065-43**

8,5 cm  
gebogen, leicht stumpf, Blattlänge 6 mm  
curved, slightly blunt, 6 mm blades  
courbe, mousse, lames 6 mm  
curvo, romo, hojas 6 mm de largo

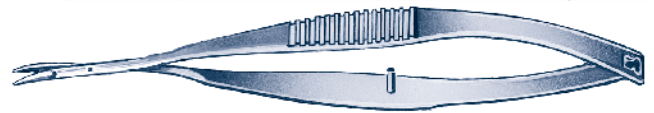

**SA60-4067-43**

9 cm  
gebogen, leicht stumpf, Blattlänge 6,5 mm  
curved, slightly blunt, 6,5 mm blades  
courbe, mousse, lames 6,5 mm  
curvo, romo, hojas 6,5 mm de largo

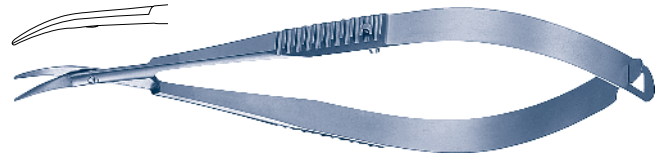

**SA60-4070-41**

8,5 cm  
Trabekular-Schere, gerade,  
Blattlänge 6,5 mm  
Trabecular scissors, straight,  
6,5 mm blades  
Ciseaux à trabéculaires, droit,  
lames 6,5 mm  
Tijera trabeculares, recta,  
hojas 6,5 mm de largo



**SA60-4071-41**

Trabekular-Schere, gebogen,  
Blattlänge 6,5 mm  
Trabecular scissors, curved,  
6,5 mm blades  
Ciseaux à trabéculaires, courbe,  
lames 6,5 mm  
Tijera trabeculares, curva,  
hojas 6,5 mm de largo



**KAPSELSCHEREN**  
**CAPSULE SCISSORS**

**CISEAUX CAPSULAIRES**  
**TIJERAS PARA CAPSULA**

**SA60-4054-41**  
**ONG**

9 cm  
aufgewinkelt  
angled on flat  
angulaire  
angulado

**SA60-4056-41**

8,3 cm

**SA60-4057-41**  
**ONG**

9 cm  
gebogen  
curved  
courbe  
curvo

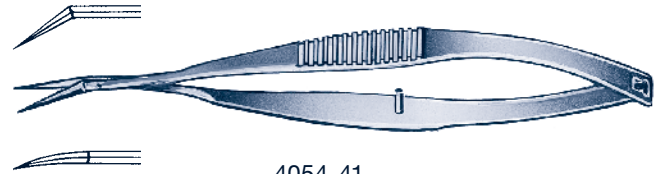

4054-41

**SA60-4058-41**  
**VANNAS**

8,3 cm  
aufgewinkelt, Blattlänge 3 mm  
angled on flat, 3 mm blades  
angulaire, lames 3 mm  
angulado, hojas 3 mm de largo

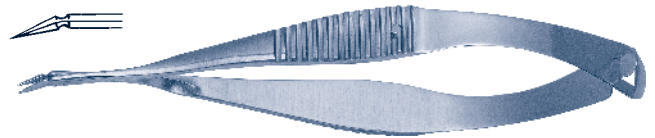

**SA60-4075-41**  
**URIBE-STERN**

10,5 cm  
aufgewinkelt, gebogen  
angled on flat, curved  
angulaire, courbe  
angulado, curvo

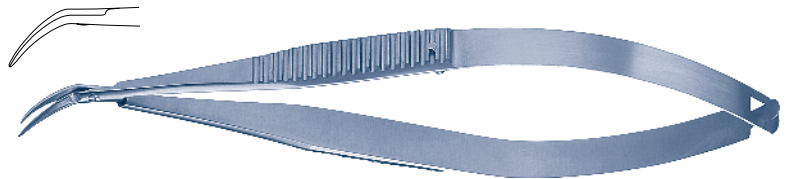

**SA60-4083-41**  
**GILLS-VANNAS**

10,5 cm  
aufgewinkelt  
angled on flat  
angulaire  
angulado

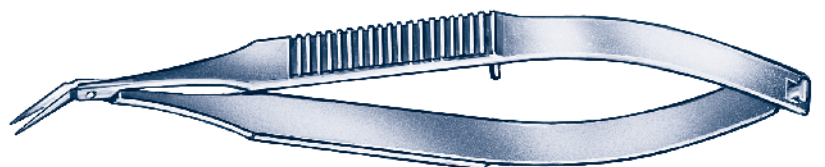

FEDERSCHEREN FÜR MIKRO-CHIRURGIE  
SPRING HANDLE SCISSORS FOR MICRO-SURGERY

CISEAUX À MICRO-CHIRURGIE  
TIJERAS PARA MICRO-CIRUGIA

**SA60-4200-71**

10 cm  
gerade, Blattlänge 8 mm  
straight, 8 mm blades  
droit, lames 8 mm  
recto, hojas 8 mm de largo

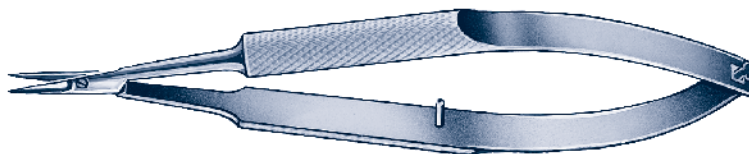

**SA60-4201-71**

10 cm  
gebogen, Blattlänge 8 mm  
curved, 8 mm blades  
courbe, lames 8 mm  
curvo, hojas 8 mm de largo

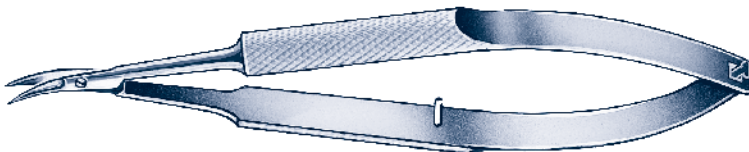

**SA60-4205-43**

10 cm  
Keratome Schere, stark gebogen, stumpf  
Corneal scissors, strong curved, blunt  
Micro ciseaux, très courbe, mousse  
Tijera para la cornea, muy curva, roma

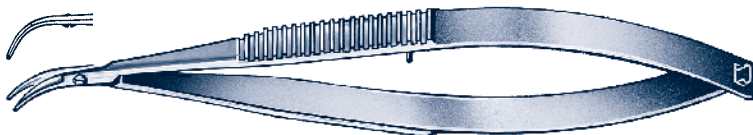

**SA60-4207-73**

10 cm  
Keratome Schere, stark gebogen, stumpf  
Corneal scissors, strong curved, blunt  
Micro ciseaux, très courbe, mousse  
Tijera para la cornea, muy curva, roma

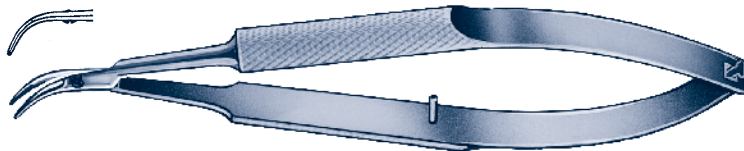

**SA60-4209-71**

KOCH  
11 cm  
stark gebogen  
strong curved  
très courbe  
muy curvo

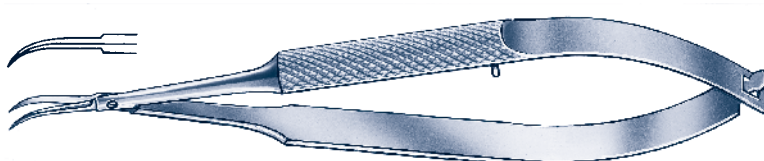

**SA60-4210-43**

10 cm  
aufgewinkelt  
angled on flat  
angulaire  
angulado

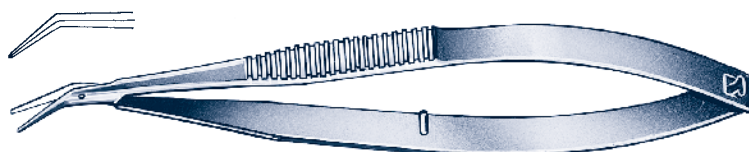

**SA60-4212-73**

10,5 cm  
aufgewinkelt  
angled on flat  
angulaire  
angulado

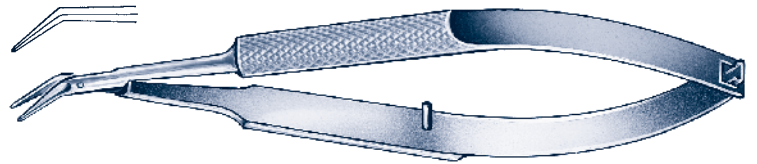

**SA60-4214-83**

**BARRAQUER MINIATUR**

10,5 cm  
mit Stop, aufgewinkelt, rechts  
with stop, angled on flat, right  
avec arrêt, angulaire, à droite  
con stop, angulado, derecha

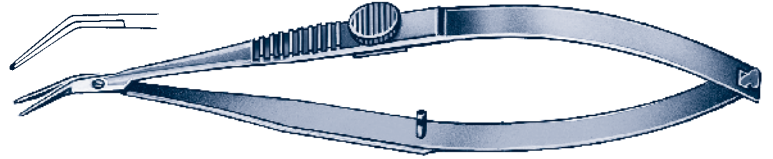

**SA60-4218-83**

**BARRAQUER MINIATUR**

10,5 cm  
mit Stop, aufgewinkelt, links  
with stop, angled on flat, left  
avec arrêt, angulaire, à gauche  
con stop, angulado, izquierda

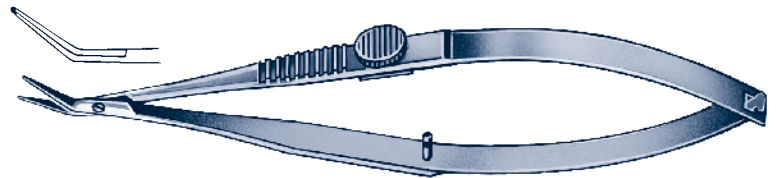

**SA60-4224-41**

10 cm  
kniegebogen, spitz  
angled to side, pointed  
coudé, pointée  
angulado, aguda

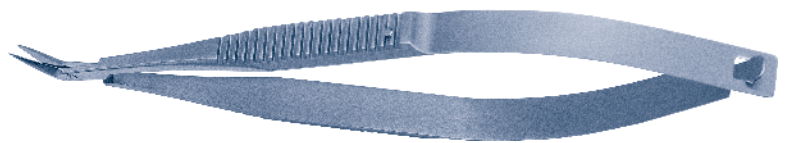

**SA60-4224-43**

10 cm  
kniegebogen, stumpf  
angled to side, blunt  
coudé, mousse  
angulado, romo

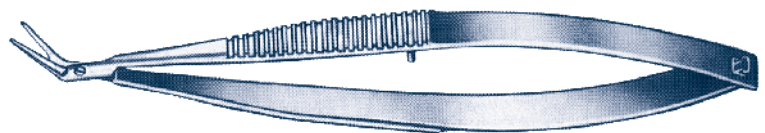

**SA60-4226-73**

10 cm  
kniegebogen, stumpf  
angled to side, blunt  
coudé, mousse  
angulado, romo

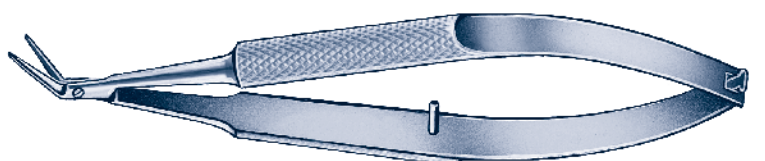

## FEDERSCHEREN FÜR MIKRO-CHIRURGIE

### SPRING HANDLE SCISSORS FOR MICRO-SURGERY

## CISEAUX À MICRO-CHIRURGIE

### TIJERAS PARA MICRO-CIRUGIA

#### SA60-4231-41

WESTCOTT (Mc PHERSON)

10,5 cm

gebogen, spitz  
curved, pointed  
courbe, pointée  
curvo, aguda

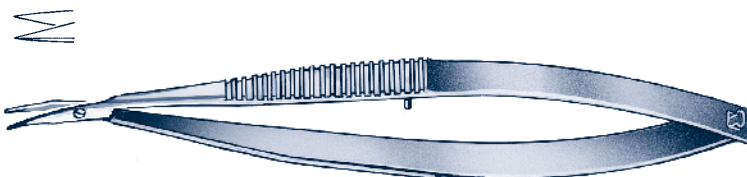

#### SA60-4231-43

WESTCOTT (Mc PHERSON)

10,5 cm

gebogen, stumpf  
curved, blunt  
courbe, mousse  
curvo, romo



#### SA60-4251-43

Mc GUIRE

10,5 cm

rechts  
right  
à droite  
derecha

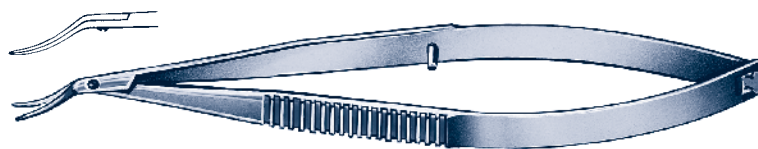

#### SA60-4253-53

Mc GUIRE

10,5 cm

links  
left  
à gauche  
izquierda

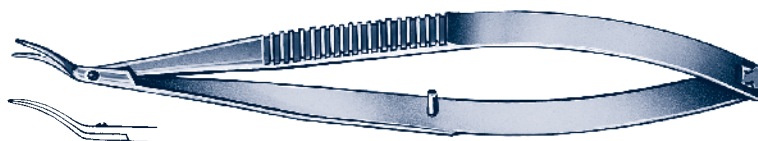

#### SA60-8079-61

CASTROVIEJO

13 cm

Keratoplastikscherer, gebogen, spitz  
Keratoplasty scissors, curved, pointed  
Ciseaux pour kératoplastie, courbe, pointu  
Tijera para queratoplastia, curva, aguda

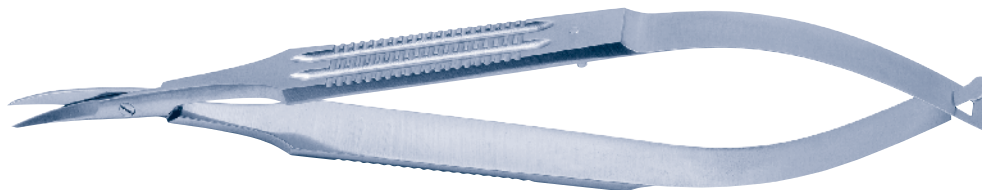

#### SA60-8745-63

CASTROVIEJO

13 cm

Keratoplastikscherer, gebogen, stumpf  
Keratoplasty scissors, curved, blunt  
Ciseaux pour kératoplastie, courbe, mousse  
Tijera para queratoplastia, curva, roma

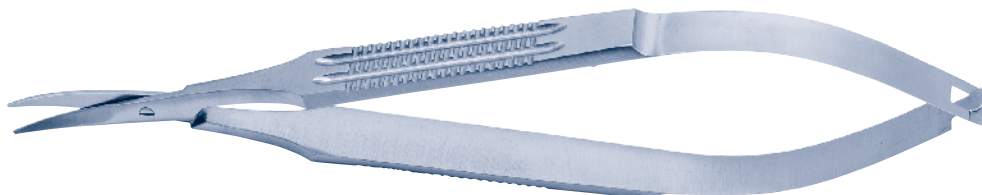

#### SA60-6138-43

OSHER

Linsenschneider, gezahnt  
IOL Scissors, serrated  
Ciseaux pour IOL, denté  
Tijera para IOL, serrada



**SA60-4301-47**  
TROUTMAN  
Original-Modell

10 cm  
links  
left  
à gauche  
izquierda

**SA60-4309-47**  
TROUTMAN

10 cm  
stark gebogen  
strong curved  
très courbe  
muy curvo

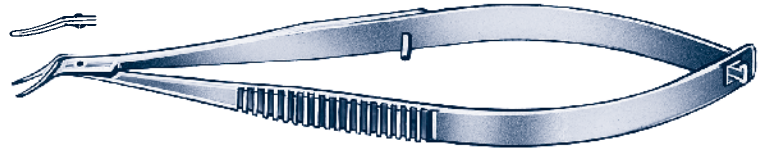

**SA60-4301-56**  
TROUTMAN  
Original-Modell

10 cm  
rechts  
right  
à droite  
derecha

**SA60-4309-56**  
TROUTMAN

10 cm  
stark gebogen  
strong curved  
très courbe  
muy curvo

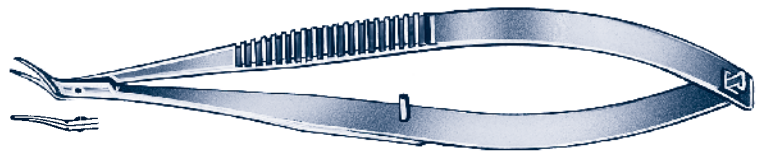

**SA60-4303-86**  
TROUTMAN

10 cm  
rechts, mit Stop  
right, with stop  
à droite, avec arrêt  
derecha, con stop

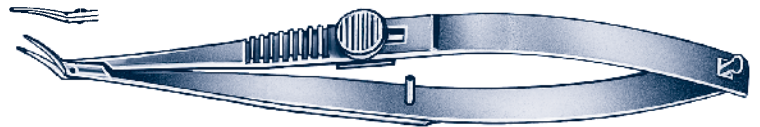

**SA60-4303-87**  
TROUTMAN

10 cm  
links, mit Stop  
left, with stop  
à gauche, avec arrêt  
izquierda, con stop

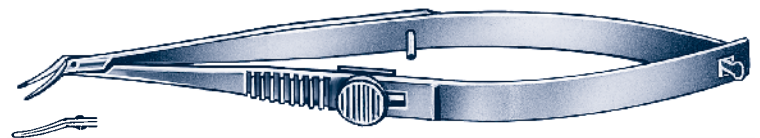

**SA60-4305-76**

10 cm  
rechts  
right  
à droite  
derecha

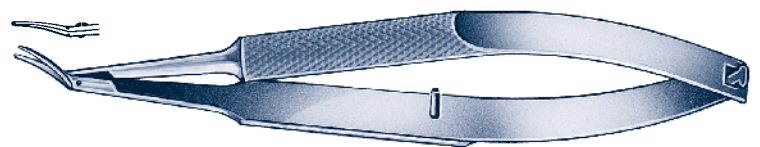

**SA60-4305-77**

10 cm  
links  
left  
à gauche  
izquierda

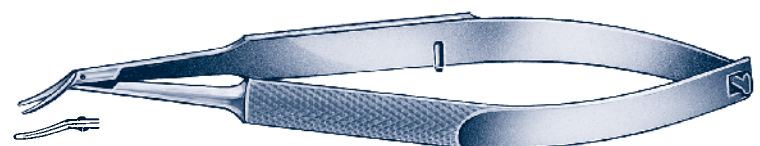

**SA60-4321-46**

KATZIN

10 cm  
rechts  
right  
à droite  
derecha

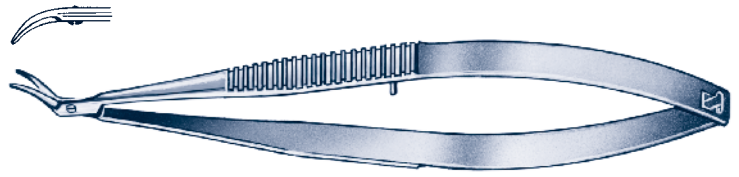

**4321-57**

KATZIN

10 cm  
links  
left  
à gauche  
izquierda

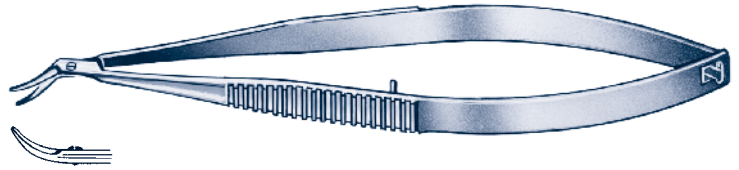

**4323-86**

KATZIN

10 cm  
rechts, mit Stop  
right, with stop  
à droite, avec arrêt  
derecha, con stop

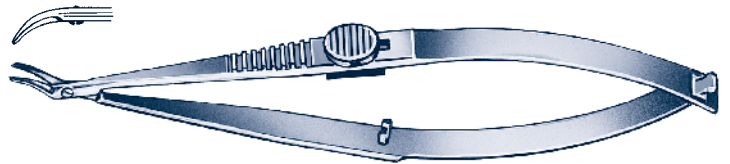

**SA60-4323-87**

KATZIN

10 cm  
links, mit Stop  
left, with stop  
à gauche, avec arrêt  
izquierda, con stop

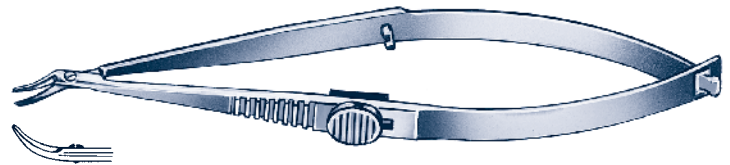

**SA60-4331-46**

KATZIN

10,5 cm  
rechts, stark gebogen  
right, strong curved  
à droite, très courbe  
derecha, muy curvo

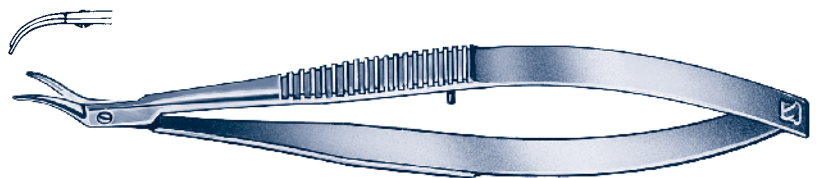

**SA60-4331-57**

KATZIN

10,5 cm  
links, stark gebogen  
left, strong curved  
à gauche, très courbe  
izquierda, muy curvo

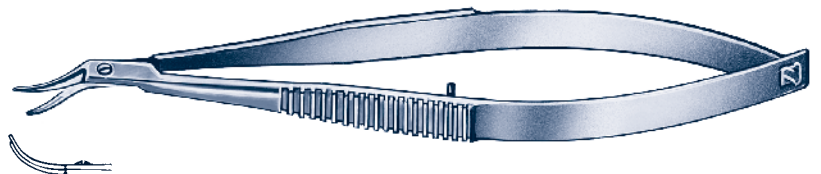

**SA60-4351-47**  
CASTROVIEJO

11 cm  
links  
left  
à gauche  
izquierda

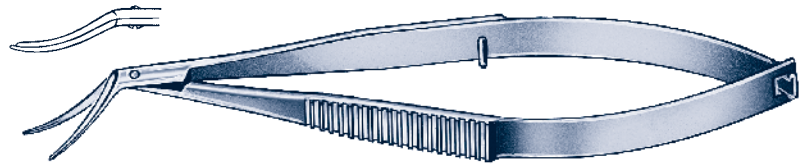

**SA60-4351-56**  
CASTROVIEJO

11 cm  
rechts  
right  
à droite  
derecha

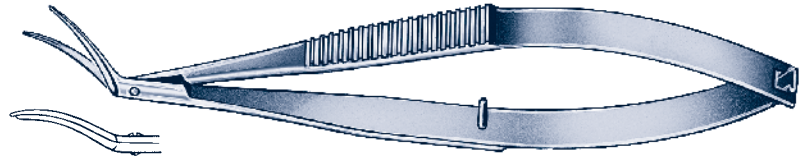

**SA60-4361-47**  
CASTROVIEJO MINIATUR

11 cm  
links  
left  
à gauche  
izquierda

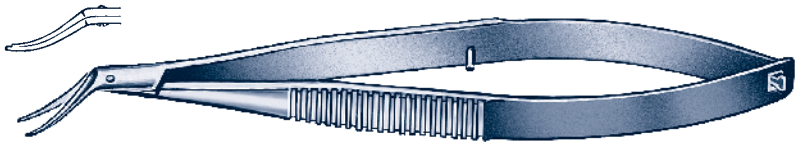

**SA60-4361-56**  
CASTROVIEJO MINIATUR

11 cm  
rechts  
right  
à droite  
derecha

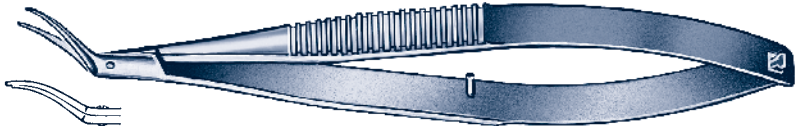

**SA60-4363-87**  
CASTROVIEJO MINIATUR

11 cm  
links, mit Stop  
left, with stop  
à gauche, avec arrêt  
izquierda, con stop

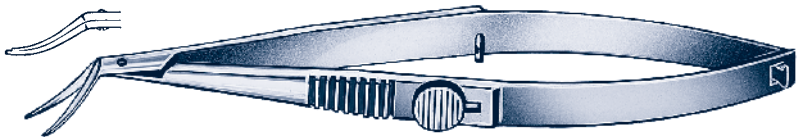

**SA60-4363-86**  
CASTROVIEJO MINIATUR

11 cm  
rechts, mit Stop  
right, with stop  
à droite, avec arrêt  
derecha, con stop

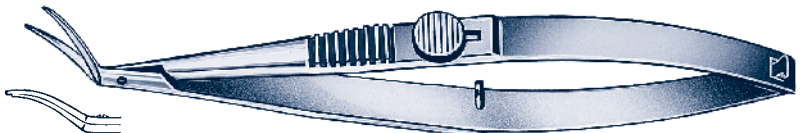

**SA60-14363-86**

CASTROVIEJO MINIATUR

10,5 cm

mit Stop, rechts  
with stop, right  
avec arrêt, à droite  
con stop, derecha

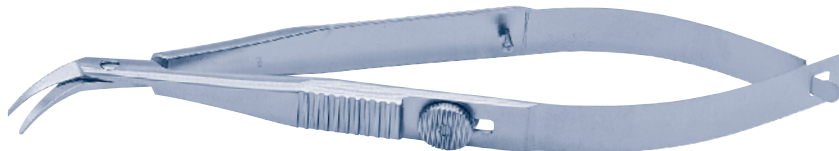

**SA60-4367-86**

CASTROVIEJO MINIATUR

10,5 cm

mit Stop, rechts  
with stop, right  
avec arrêt, à droite  
con stop, derecha

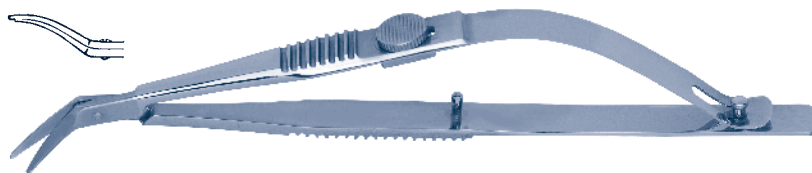

**SA60-4367-87**

CASTROVIEJO MINIATUR

10,5 cm

mit Stop, links  
with stop, left  
avec arrêt, à gauche  
con stop, izquierda

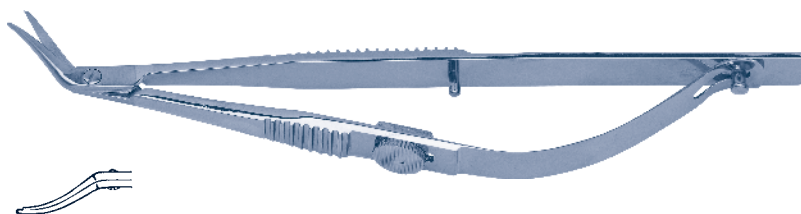

**SA60-4371-47**

CASTROVIEJO MICRO-MINIATUR

10,5 cm

links  
left  
à gauche  
izquierda

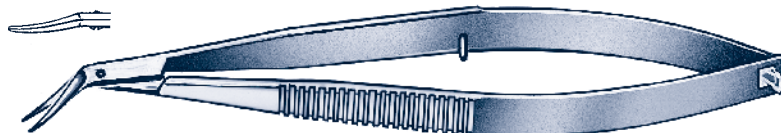

**SA60-SA60-4371-56**

CASTROVIEJO MICRO-MINIATUR

10,5 cm

rechts  
right  
à droite  
derecha

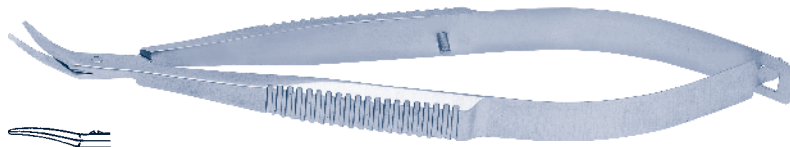

**14371-47**

CASTROVIEJO MICRO-MINIATUR

10,5 cm

links  
left  
à gauche  
izquierda

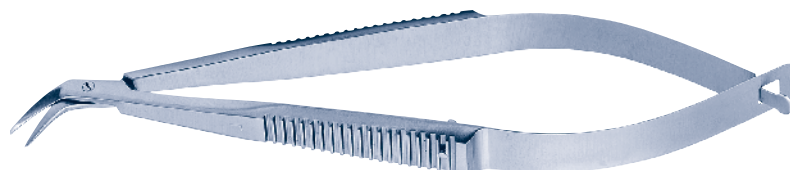



**SA60-4400-43**  
CASTROVIEJO

9 cm  
kniegebogen  
angled to side  
coudé  
angulado

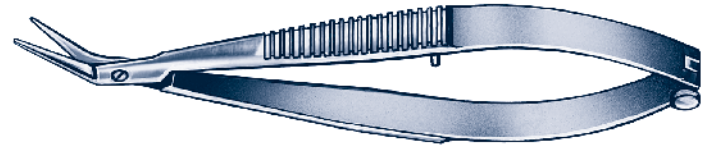

**SA60-4403-43**  
CASTROVIEJO

9,5 cm  
leicht gebogen  
slightly curved  
légèrement courbé  
ligeramente curvo

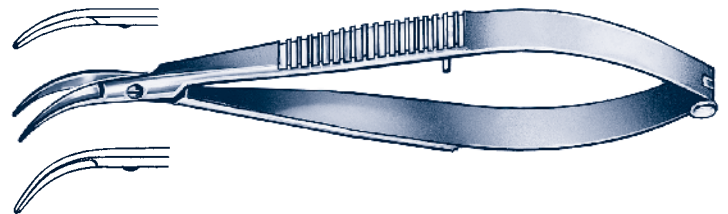

**SA60-4405-41**  
CASTROVIEJO

9,5 cm  
stark gebogen  
strong curved  
très courbe  
muy curvo



**SA60-4405-43**

**SA60-4411-83**  
BARRAQUER – MODELL FRANZ

11 cm  
mit Stop, aufgewinkelt, rechts  
with stop, angled on flat, right  
avec arrêt, angulaire, à droit  
con stop, angulada, derecha

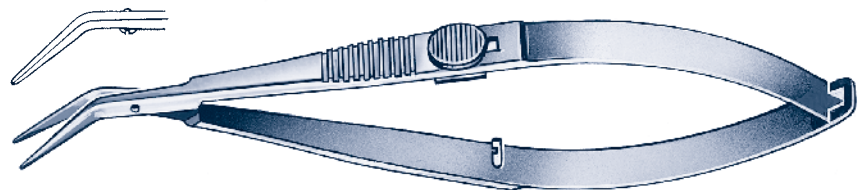

**SA60-4413-83**  
BARRAQUER – MODELL FRANZ

11 cm  
mit Stop, aufgewinkelt, links  
with stop, angled on flat, left  
avec arrêt, angulaire, à gauche  
con stop, angulada, izquierda

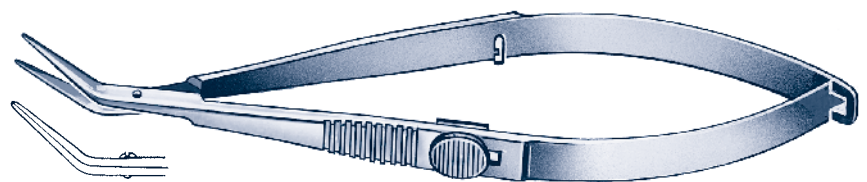

**HORNHAUTSCHEREN**

**CORNEAL SCISSORS**

**CISEAUX POUR LA CORNÉE**

**TIJERAS PARA LA CORNEA**

**SA60-4415-43**  
CASTROVIEJO

10,0 mm

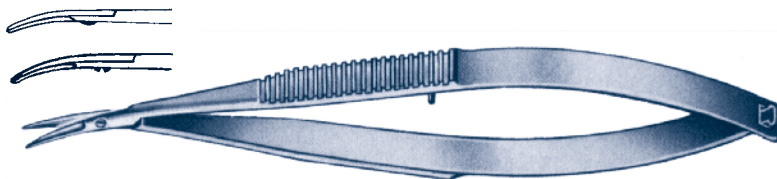

**SA60-4409-43**  
CASTROVIEJO

11,5 mm

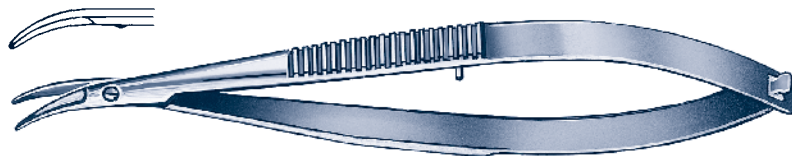

**SA60-4417-43**  
CASTROVIEJO

13,5 mm

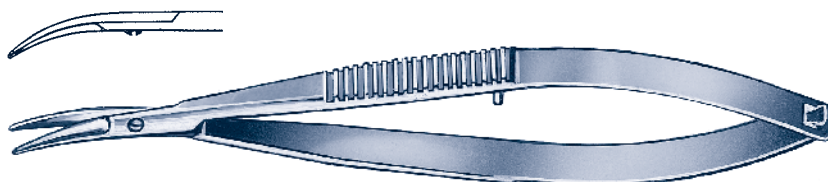

**SA60-4419-43**  
CASTROVIEJO

11 cm  
16 mm

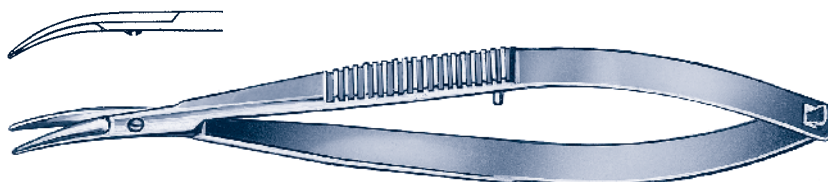

**SA60-14001-43**  
CASTROVIEJO

10,5 cm  
gebogen, Blattlänge 11 mm  
curved, 11 mm blades  
courbe, lames 11 mm  
curvo, hojas 11 mm de largo

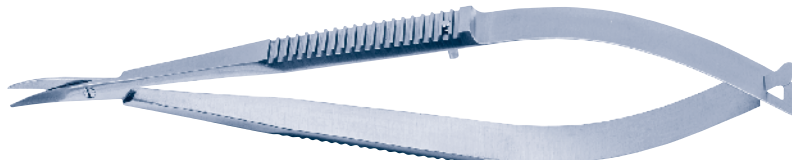

**SA60-4420-43**  
CASTROVIEJO

10,5 cm  
kniegebogen  
angled to side  
coudé  
angulado

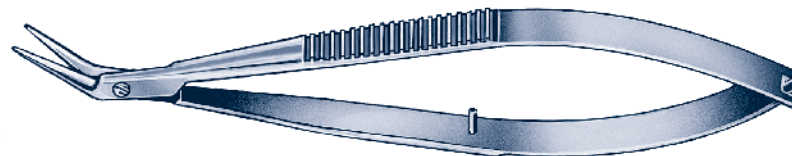

**SA60-4420-41**  
CASTROVIEJO

10,5 cm  
Keratoplastikschere, kniegebogen  
Keratoplasty scissors, angled to side  
Ciseaux pour kératoplastie, coudé  
Tijera para queratoplastia, angulada

**SA60-4420-42**

**SA60-4420-43**

**SA60-4420-44**

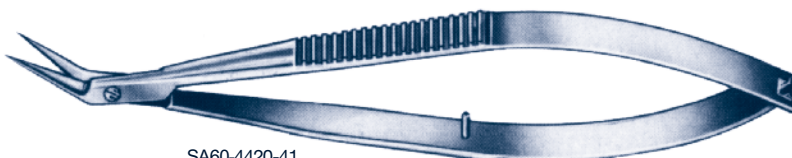

SA60-4420-41

**SA60-4423-43**

MACKENSEN

8,5 cm

Keratoplastikschere, stark gebogen  
Keratoplasty scissors, strong curved  
Ciseaux pour kératoplastie, très courbe  
Tijera para queratoplastia, muy curva



**SA60-8173-43**

AEBLI

12 cm

aufgewinkelt, rechts  
angled on flat, right  
angulaire, à droite  
angulado, derecha

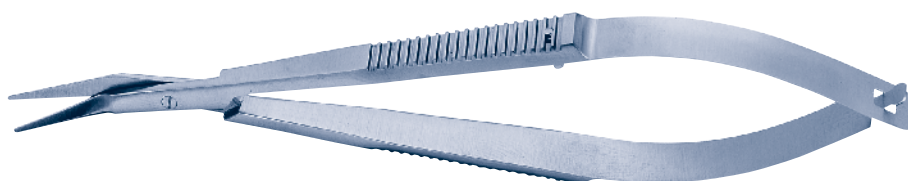

SA60-8173-43

**SA60-8173-47**

AEBLI

12 cm

aufgewinkelt, links  
angled on flat, left  
angulaire, à gauche  
angulado, izquierda

**SA60-4431-43**  
CASTROVIEJO

11 cm  
 Synechien-Schere  
 Synechia scissors  
 Ciseaux à synéchies  
 Tijera de sinequia

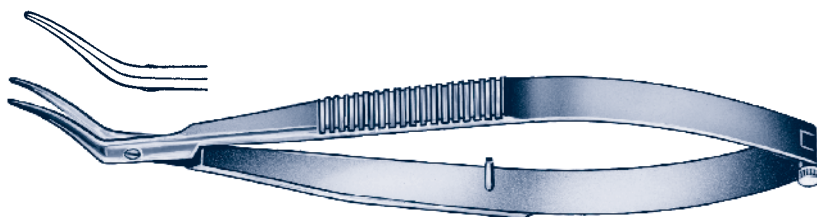
**SA60-4432-43**

10 cm  
 Mikro Schere, 90° kniegebogen  
 Micro Scissors, 90° angled to side  
 Ciseaux micro, 90° coudé  
 Micro tijera, 90° angulada

**SA60-8658-43**  
CASTROVIEJO

11 cm  
 Keratoplastikschere, gewinkelt  
 Keratoplasty scissors, angled  
 Ciseaux pour kératoplastie, angulaire  
 Tijera para queratoplastia, angulada

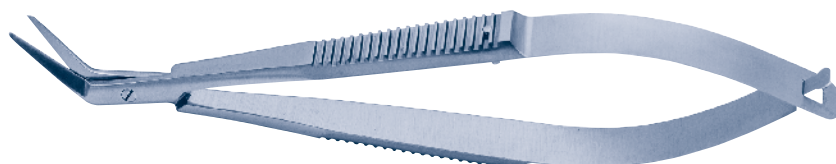

**SA60-4551-41**  
WESTCOTT

11,5 cm  
gebogen, spitz  
curved, pointed  
courbe, pointu  
curvo, agudo

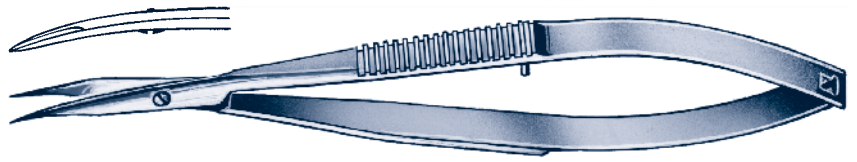

**SA60-4550-43**  
WESTCOTT

11,5 cm  
gerade, stumpf  
straight, blunt tips  
droit, mousse  
recto, romo

**SA60-4551-43**  
WESTCOTT

11,5 cm  
gebogen, stumpf  
curved, blunt tips  
courbe, mousse  
curvo, romo

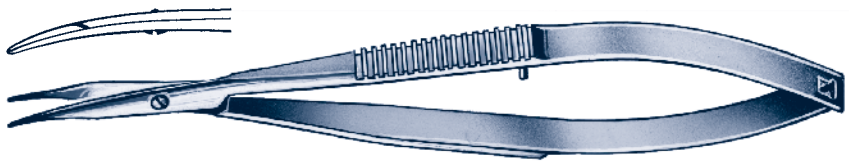

**SA60-4551-53**  
WESTCOTT

11,5 cm  
gebogen, stumpf, links  
curved, blunt tips, left  
courbe, mousse, à gauche  
curvo, romo, izquierda

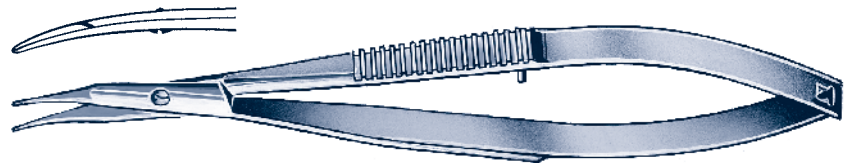

**SA60-4553-43**  
WESTCOTT

13 cm  
gebogen, stumpf  
curved, blunt tips  
courbe, mousse  
curvo, romo  
130 mm

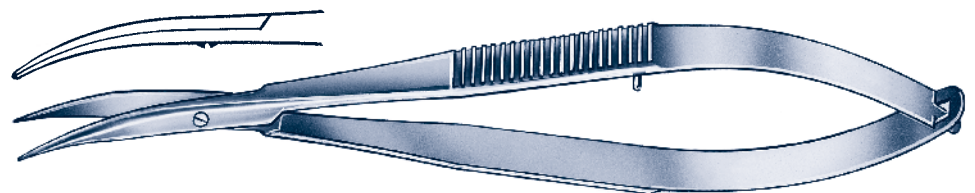

**SA60-4555-61**  
WESTCOTT

13,5 cm  
gebogen, spitz  
curved, pointed  
courbe, pointu  
curvo, agudo

**SA60-4555-63**  
WESTCOTT

13,5 cm  
gebogen, stumpf  
curved, blunt tips  
courbe, mousse  
curvo, romo

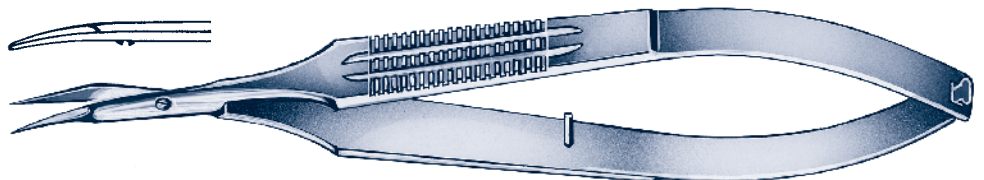

**SA60-4557-43**  
WESTCOTT

11 cm  
Kleines Modell, gebogen, stumpf  
Small model, curved, blunt  
Modèle petite, courbe, mousse  
Modelo pequeño, curvo, romo

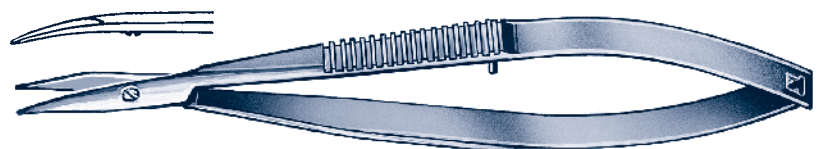

SEHNENSCHEREN  
TENOTOMY SCISSORS

CISEAUX À TÉNOTOMIE  
TIJERAS PARA TENOTOMIA

**SA60-6851-43**  
WESTCOTT

12 cm  
gebogen  
curved  
courbe  
curvo

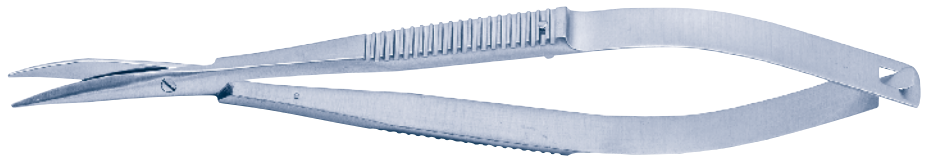

**SA60-6851-43Z**  
WESTCOTT

12 cm  
gebogen, gezahnt  
curved, serrated  
courbe, denté  
curvo, serrada

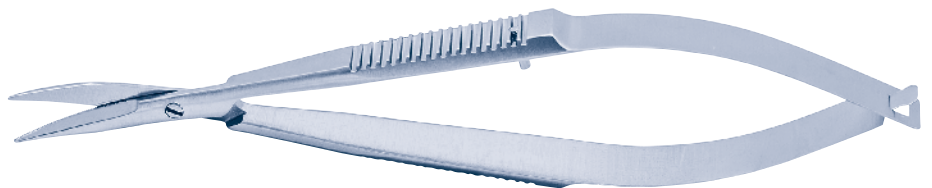

**SA60-8770-63**  
WESTCOTT

13,5 cm  
gerade  
straight  
droit  
recto

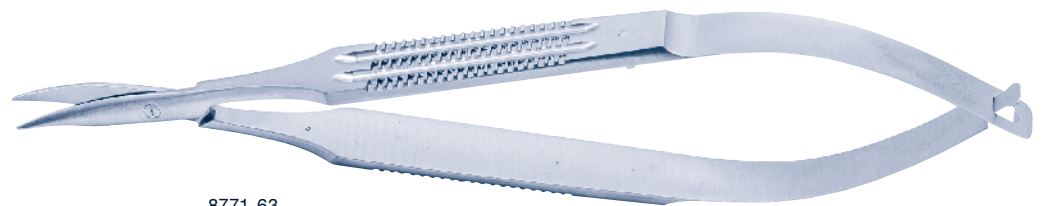

8771-63

**SA60-8771-63**  
WESTCOTT

13,5 cm  
gebogen  
curved  
courbe  
curvo

**SA60-4600-03**  
STEVENS

10,5 cm  
gerade, stumpf  
straight, blunt tips  
droit, mousse  
recto, romo



**SA60-4601-03**  
STEVENS

10,5 cm  
gebogen, stumpf  
curved, blunt tips  
courbe, mousse  
curvo, romo

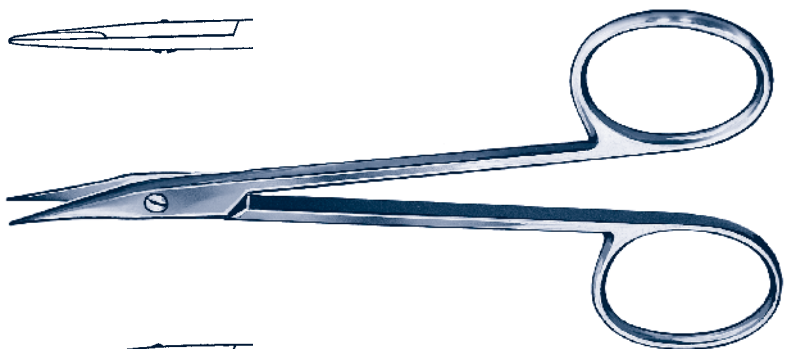

**SA60-4601-01**  
STEVENS

10,5 cm  
gebogen, spitz  
curved, pointed  
courbe, pointu  
curvo, agudo

**4604-03**  
STEVENS

11 cm  
gerade, stumpf  
straight, blunt tips  
droit, mousse  
recto, romo



**SA60-4605-03**  
STEVENS

11 cm  
gebogen, stumpf  
curved, blunt tips  
courbe, mousse  
curvo, romo

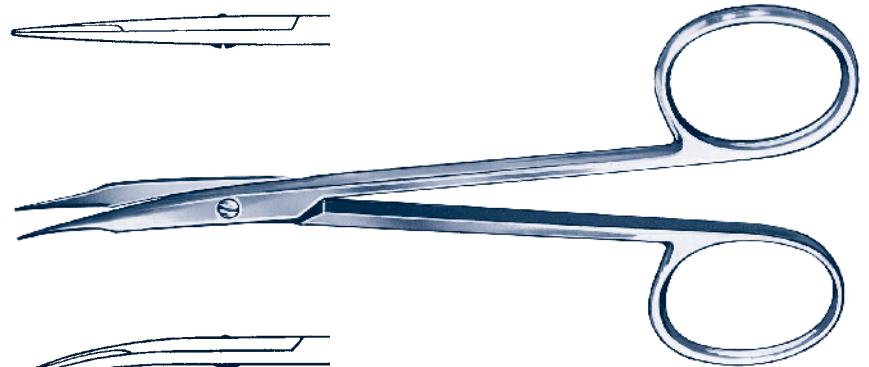

**SA60-4605-01**  
STEVENS

11 cm  
gebogen, spitz  
curved, pointed  
courbe, pointu  
curvo, agudo



**SA60-4610-03**  
STEVENS

11,5 cm  
gerade, stumpf  
straight, blunt tips  
droit, mousse  
recto, romo



**SA60-4611-03**  
STEVENS

11,5 cm  
gebogen, stumpf  
curved, blunt tips  
courbe, mousse  
curvo, romo

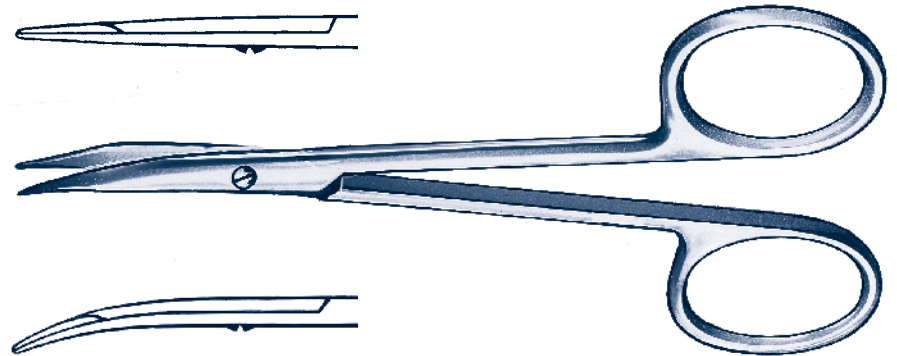

**STRABISMUSSCHEREN**  
**STRABISMUS SCISSORS**

**CISEAUX À STRABISME**  
**TIJERAS PARA ESTRABISMO**

**SA60-4622-03**  
HEIDELBERGER MODELL

9 cm  
gerade  
straight  
droit  
recto

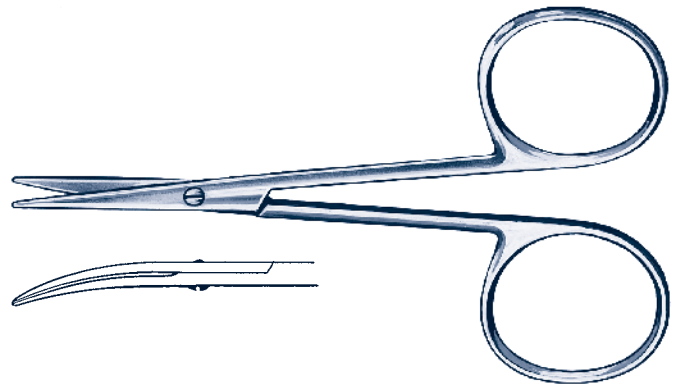

**SA60-4623-03**  
HEIDELBERGER MODELL

9 cm  
gebogen  
curved  
courbe  
curvo



**SA60-4628-03**

10,5 cm  
gerade  
straight  
droit  
recto

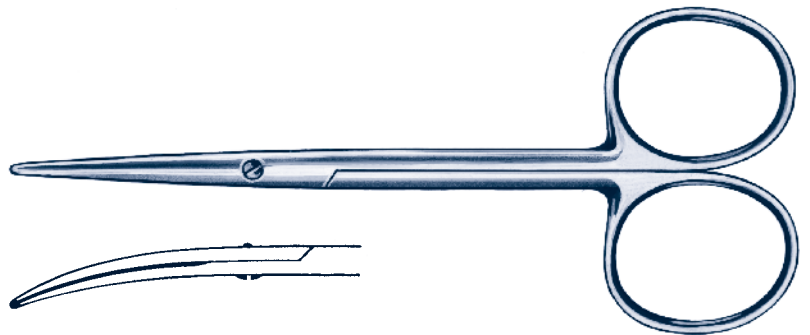

**4629-03**

10,5 cm  
gebogen  
curved  
courbe  
curvo



**SA60-4628-13**

10,5 cm  
gerade  
straight  
droit  
recto

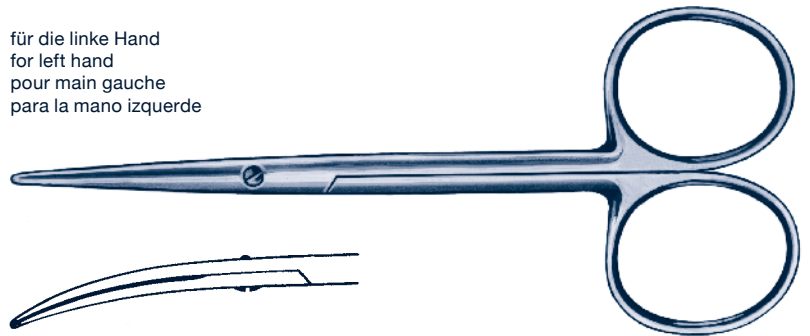

für die linke Hand  
for left hand  
pour main gauche  
para la mano izquierda

**SA60-4629-13**

10,5 cm  
gebogen  
curved  
courbe  
curvo



**SA60-4632-03**

11 cm  
gerade  
straight  
droit  
recto

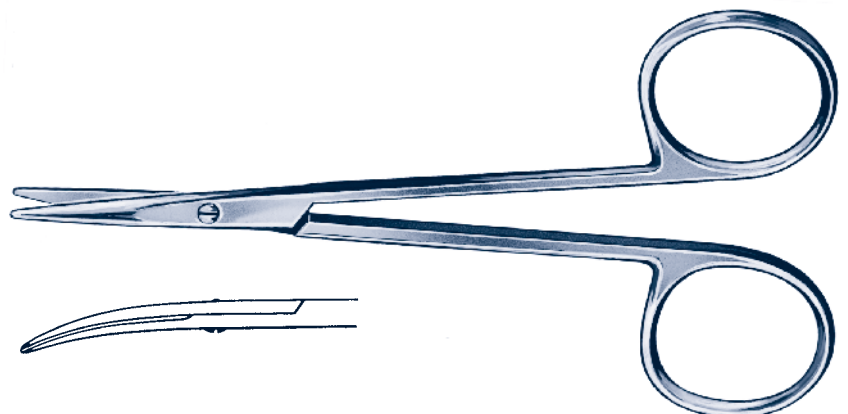

**SA60-4633-03**

11 cm  
gebogen  
curved  
courbe  
curvo



STRABISMUSSCHEREN  
STRABISMUS SCISSORS

CISEAUX À STRABISME  
TIJERAS PARA ESTRABISMO

**SA60-4635-03**

11 cm  
gebogen  
curved  
courbe  
curvo

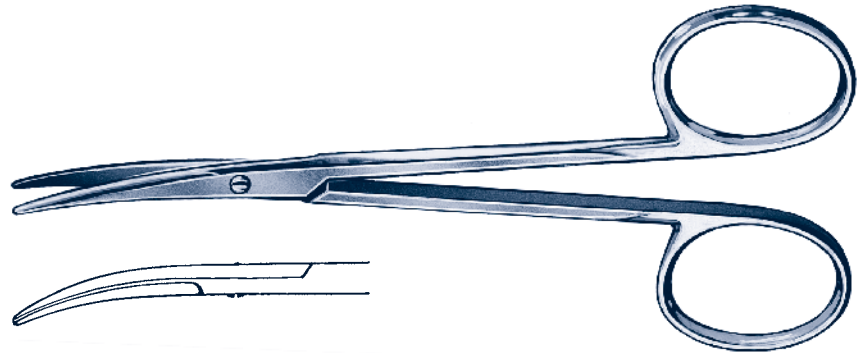

**SA60-4640-03**

12 cm  
gerade  
straight  
droit  
recto

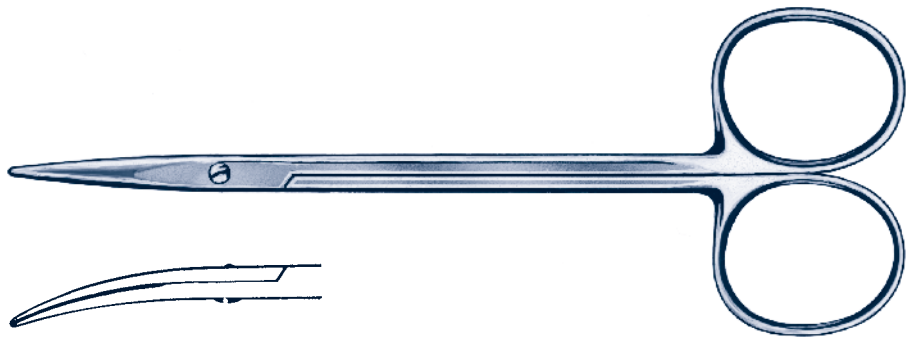

**SA60-4641-03**

12 cm  
gebogen  
curved  
courbe  
curvo



**SA60-4644-03**

12 cm  
gerade  
straight  
droit  
recto

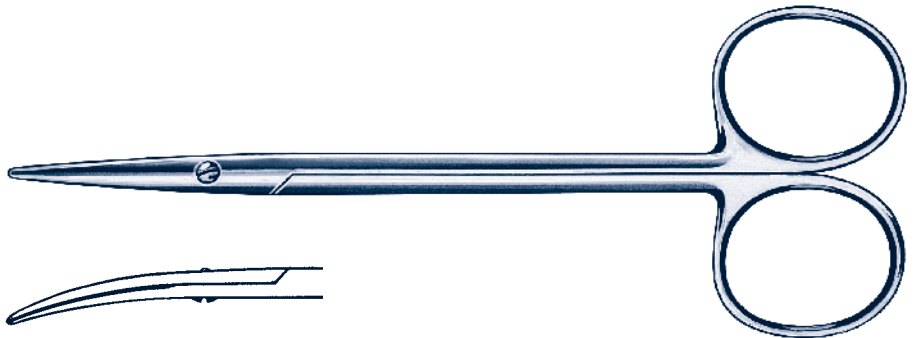

**SA60-4645-03**

12 cm  
leicht gebogen  
slightly curved  
légèrement courbe  
ligeramente curvo



**SA60-4647-03**

12 cm  
stark gebogen  
strong curved  
très courbe  
muy curvo



**SA60-4648-00**

10,5 cm  
gerade, geknüpft  
straight, probe points  
droit, boutonnés  
recto, puntas olivar

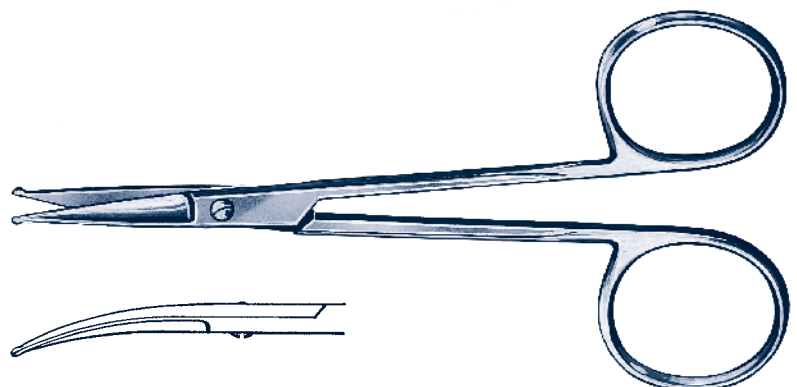

**SA60-4649-00**

10,5 cm  
gebogen, geknüpft  
curved, probe points  
courbe, boutonnés  
curvo, puntas olivar



**AUGENSCHEREN**  
**EYE SCISSORS**

**CISEAUX OCULAIRES**  
**TIJERAS OCULARES**



**SA60-4704-01**

9 cm

gerade, straight, droit, recto



**SA60-4704-03**

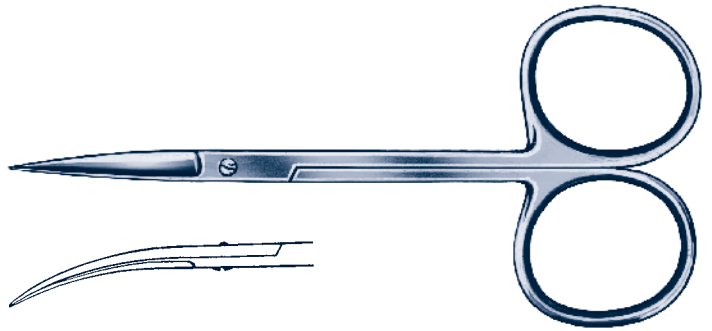

**SA60-4705-01**

9 cm

gebogen, curved, courbe, curvo



**SA60-4705-03**



**SA60-4706-01**

9,5 cm

gerade, straight, droit, recto



**SA60-4706-03**

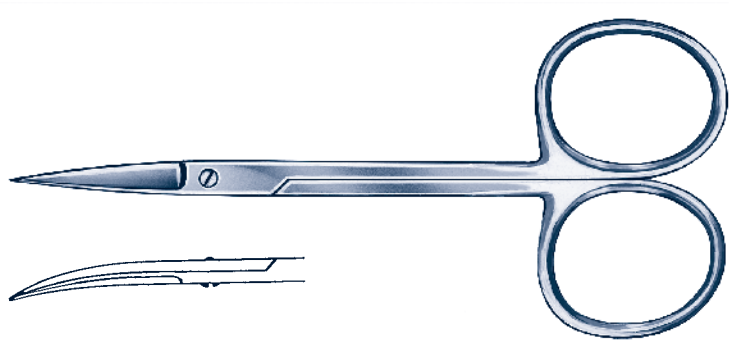

**SA60-4707-01**

9,5 cm

gebogen, curved, courbe, curvo



**SA60-4707-03**



**SA60-4708-01**

10,5 cm

gerade, straight, droit, recto



**SA60-4708-02**



**SA60-4708-03**

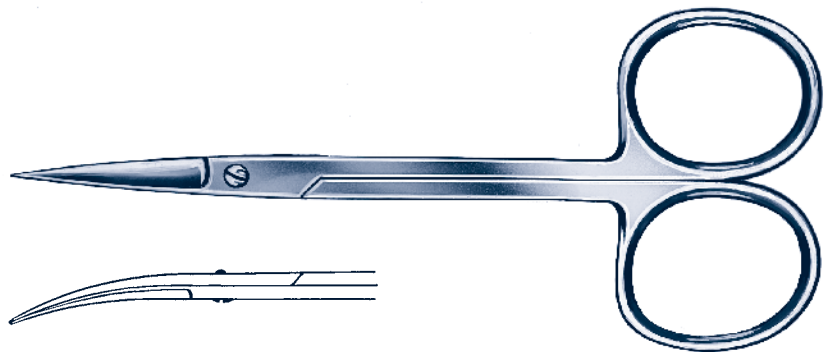

**SA60-4709-01**

10,5 cm

gebogen, curved, courbe, curvo



**SA60-4709-02**



**SA60-4709-03**



**SA60-4710-01**

11,5 cm

gerade, straight, droit, recto



**SA60-4711-01**

11,5 cm

gebogen, curved, courbe, curvo



**SA60-4711-03**

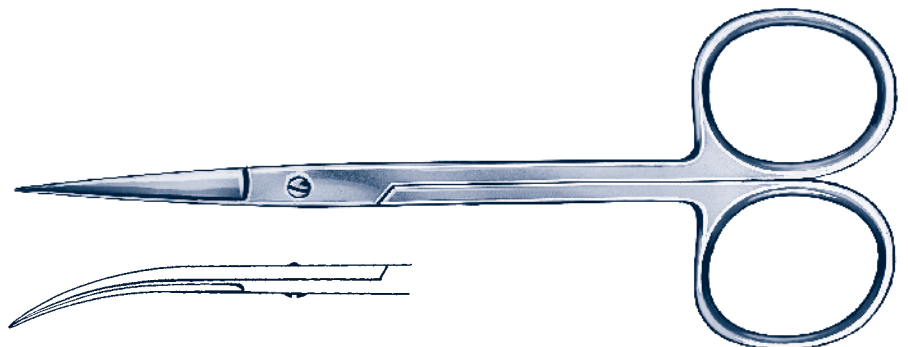

# AUGENSCHEREN

## EYE SCISSORS

# CISEAUX OCULAIRES

## TIJERAS OCULARES



**SA60-4712-01**

11,5 cm

gerade, straight, droit, recto



**SA60-4712-02**



**SA60-4712-03**



**SA60-4713-01**

11,5 cm

gebogen, curved, courbe, curvo



**SA60-4713-03**

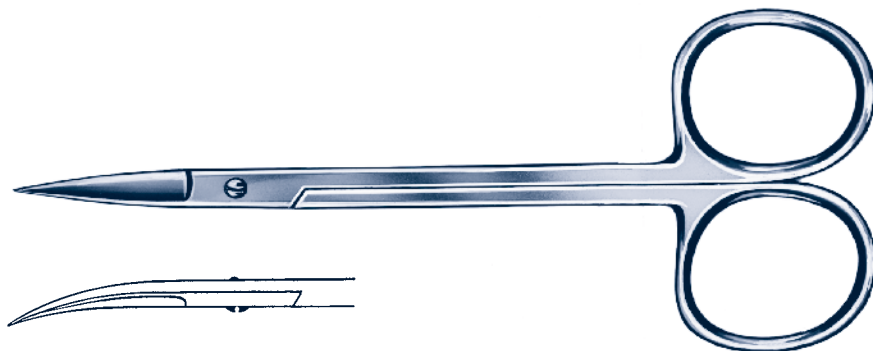

**SA60-4714-01**

10,5 cm

gerade, straight, droit, recto



**SA60-4715-01**

10,5 cm

gebogen, curved, courbe, curvo

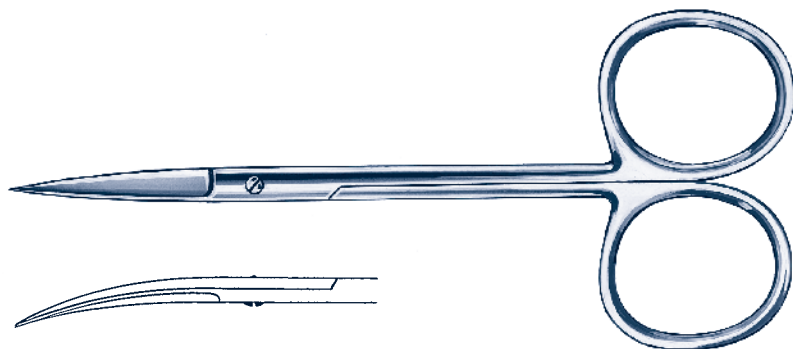

**SA60-4718-01**

12,5 cm

gerade, straight, droit, recto



**SA60-4718-02**



**SA60-4718-03**



**SA60-4719-01**

12,5 cm

gebogen, curved, courbe, curvo



**4SA60-719-02**



**SA60-4719-03**

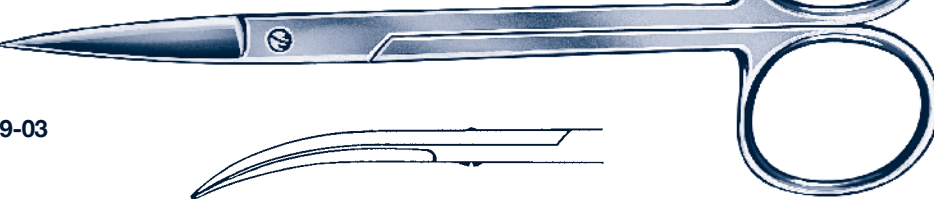

**SA60-4720-01**

BONNER MODELL

9,0 cm

gerade, straight, droit, recto



**SA60-4720-02**



**SA60-4720-03**



**SA60-4721-01**

BONNER MODELL

9,0 cm

gebogen, curved, courbe, curvo



**SA60-4721-02**



**SA60-4721-03**

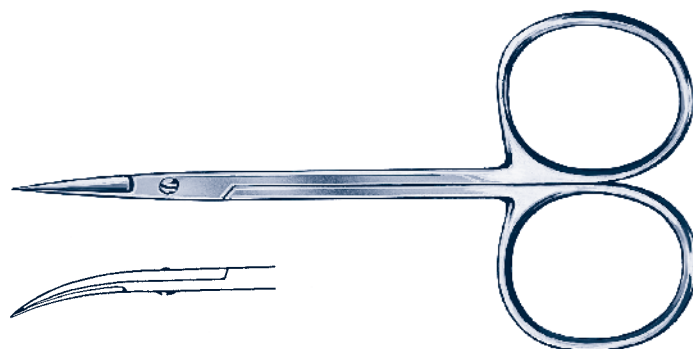

**AUGENSCHEREN**  
**EYE SCISSORS**

**CISEAUX OCULAIRES**  
**TIJERAS OCULARES**

**SA60-4752-01**

10 cm  
gerade, straight, droit, recto

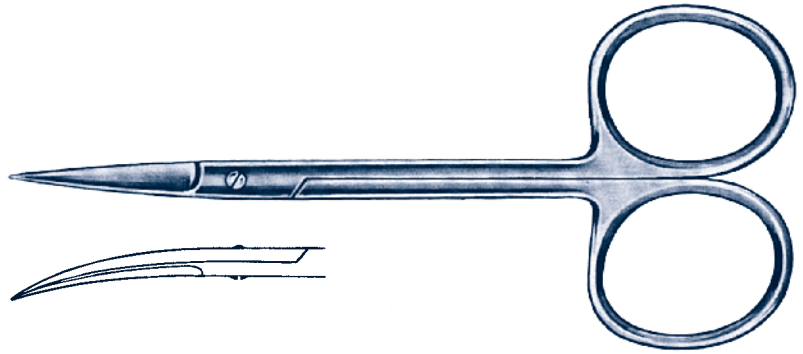

**SA60-4753-01**

10 cm  
gebogen, curved, courbe, curvo



**SA60-4752-11**

10 cm  
gerade, straight, droit, recto

für die linke Hand  
for left hand  
pour main gauche  
para la mano izquierda



**SA60-4753-11**

10 cm  
gebogen, curved, courbe, curvo

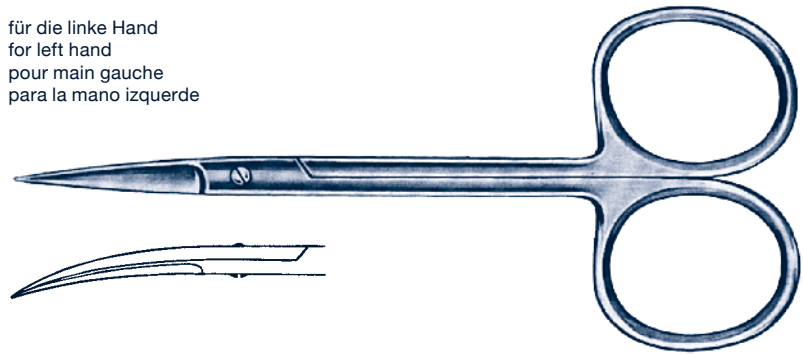

**SA60-4754-01**

11 cm  
gerade, straight, droit, recto



**SA60-4755-01**

11 cm  
gebogen, curved, courbe, curvo

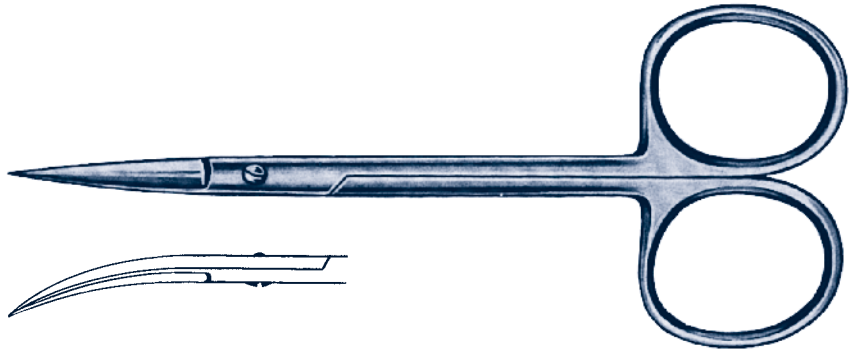

**SA60-4758-01**

12 cm  
gerade, straight, droit, recto

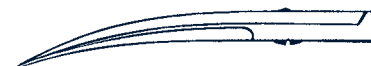

**SA60-4759-01**

12 cm  
gebogen, curved, courbe, curvo

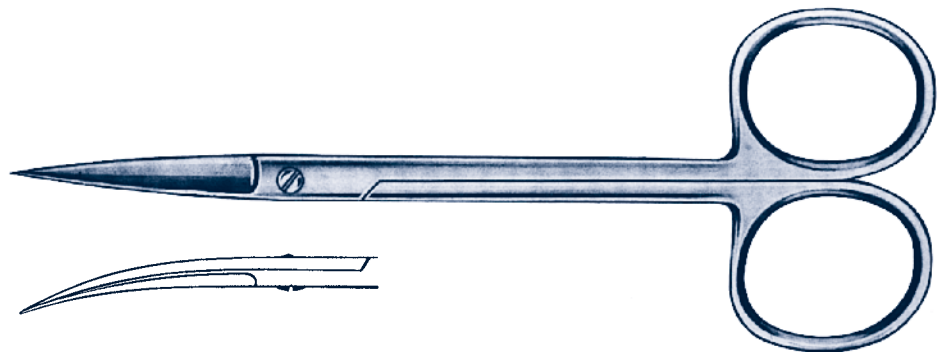

**SA60-4762-01**

10 cm  
gerade, straight, droit, recto

**SA60-4763-01**

10 cm  
gebogen, curved, courbe, curvo

mit extra großen Ringen  
with special large rings  
anneaux extrêmement  
argollas muy grande

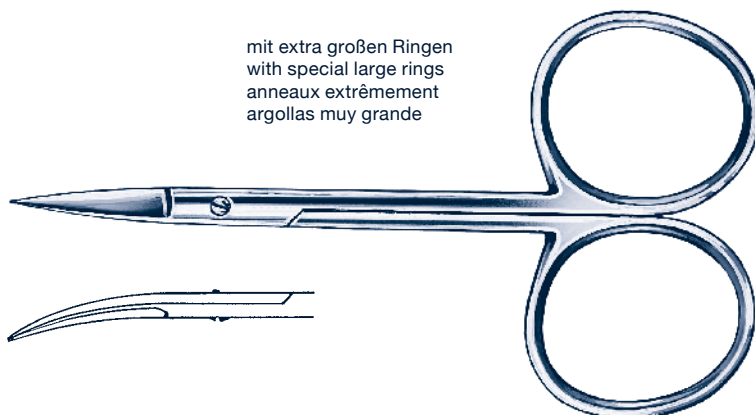

**SA60-4771-01**  
WILMER

9,5 cm  
aufgewinkelt, gezahnt  
angled on flat, serrated  
angulaire, striée  
angulada, serrada

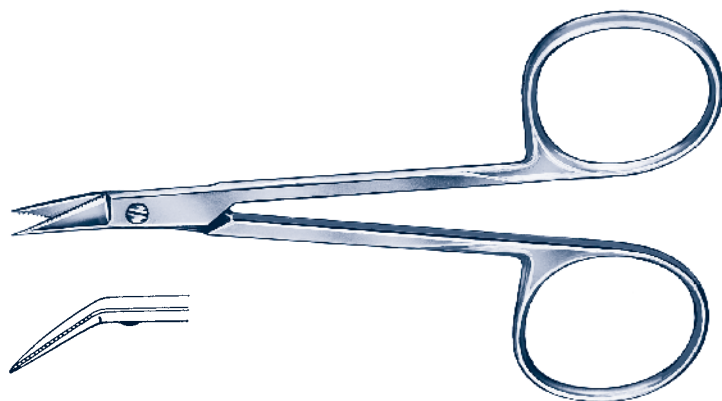

**SA60-4773-03**  
GRAEFE (WALTER)

10 cm  
aufgewinkelt  
angled on flat  
angulaire  
angulado

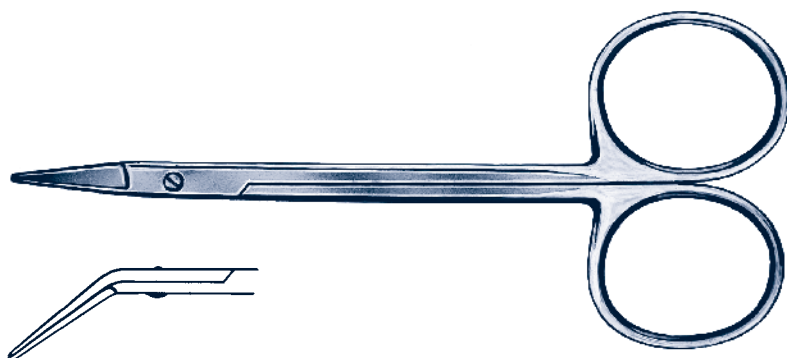

**SA60-4774-03**  
GRAEFE

10 cm  
kniegebogen  
angled to side  
coudé  
angulado

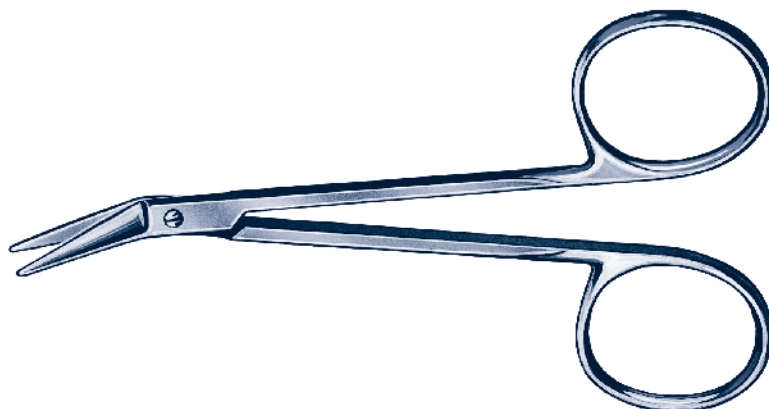

**SA60-44830-01**

11,5 cm  
kniegebogen  
angled to side  
coudé  
angulado

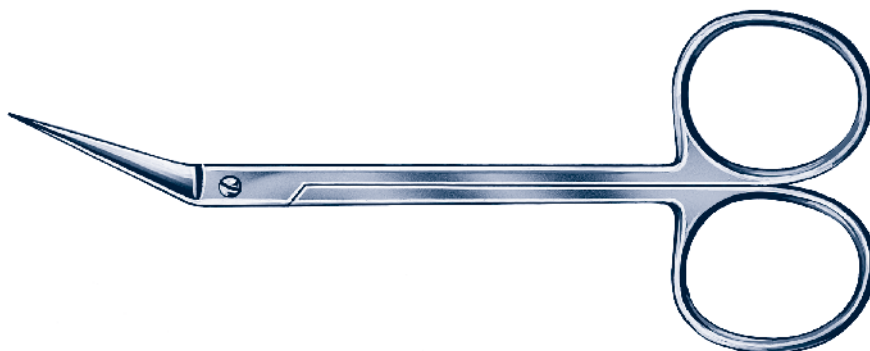

**SA60-44832-00**

11,5 cm  
kniegebogen, geknüpft  
angled to side, probe points  
coudé, boutonnées  
angulado, puntas olivar

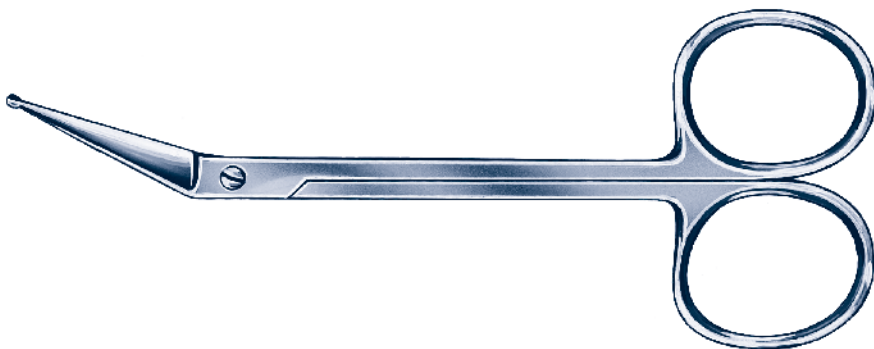

**SA60-44834-00**

11,5 cm  
kniegebogen, geknüpft/spitz  
angled to side, probe points/sharp  
coudé, boutonnées/pointu  
angulado, puntas olivar/aguda

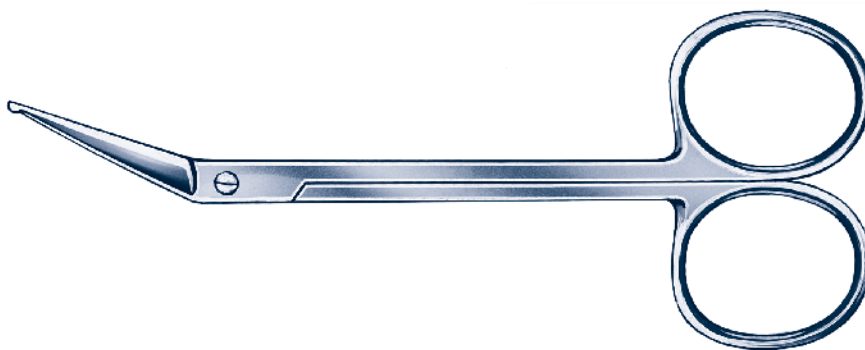

**SA60-44835-03**

Mc GUIRE  
10,5 cm

**SA60-44837-13**

Mc GUIRE  
10,5 cm  
für die linke Hand  
for left hand  
pour main gauche  
para la mano izquierda

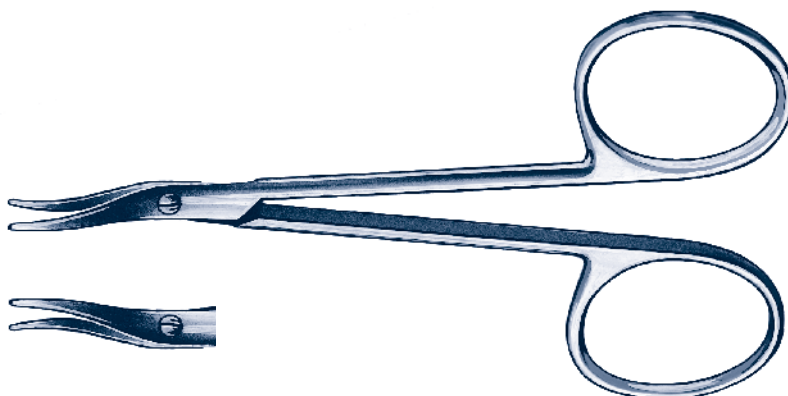

FADENSCHERE  
STITCH SCISSORS

CISEAUX POUR INCISION  
TIJERAS PARA INCISIÓN

**SA60-44006-41**

11 cm  
gerade  
straight  
droit  
recto

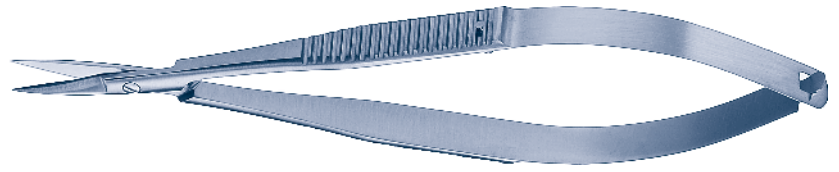

**SA60-44844-42**

10,5 cm  
mit Kerbe für den Faden  
Spencer-type notch  
avec entaille pour le fil  
con muesca para el hilo

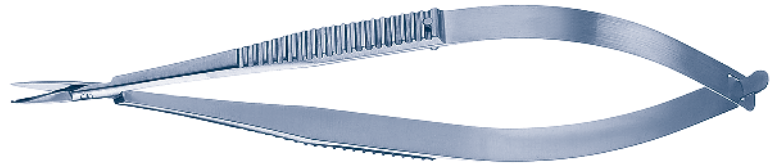

**SA60-44840-00**  
SPENCER

9 cm  
Faden- und Ligaturschere  
Stitch scissors  
Ciseaux pour incision  
Tijera para incisión



**SA60-44842-00**  
SPENCER

11 cm  
Faden- und Ligaturschere  
Stitch scissors  
Ciseaux pour incision  
Tijera para incisión

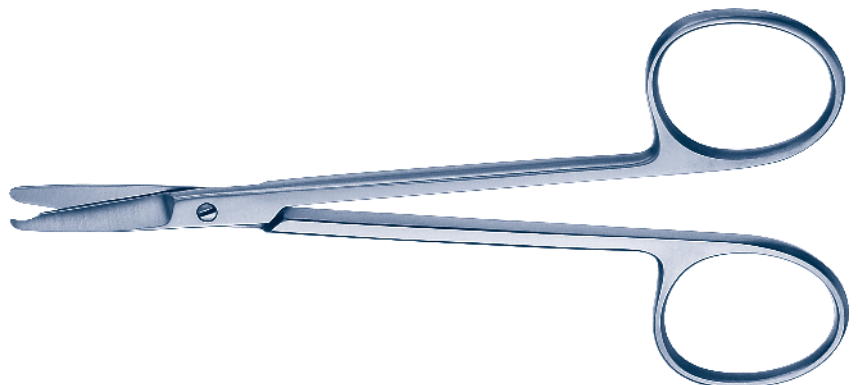

**SA60-44847-01**

10 cm  
gebogen  
curved  
courbe  
curvo

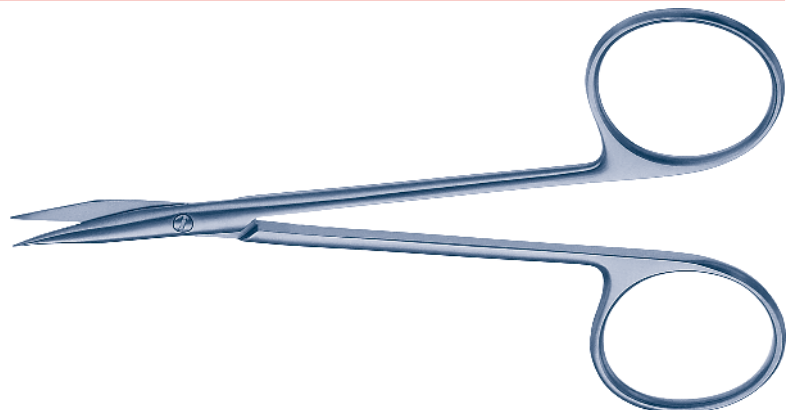

**SA60-4854-03**

12,5 cm

gerade  
straight  
droit  
recto

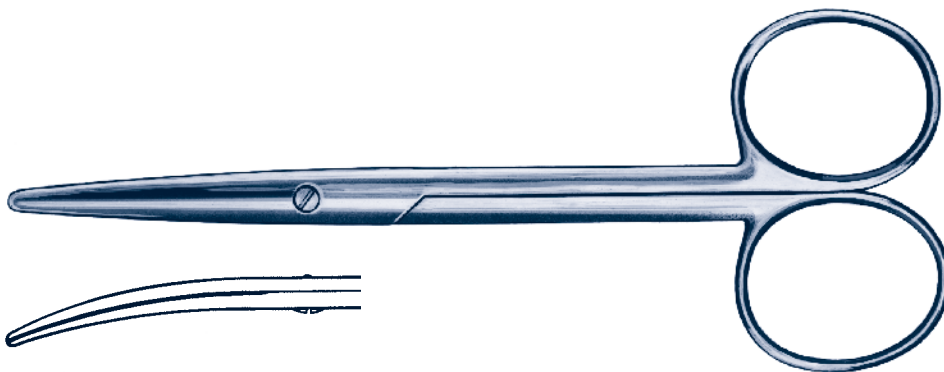

**SA60-4855-03**

12 cm

leicht gebogen  
slightly curved  
légèrement courbe  
ligeramente curvo



**SA60-4857-03**

12 cm

mittel gebogen  
medium curved  
moyennement courbe  
medio curvo



**SA60-4859-03**

11,5 cm

stark gebogen  
strong curved  
très courbe  
muy curvo



**SA60-4864-03**

13,5 cm

gerade  
straight  
droit  
recto

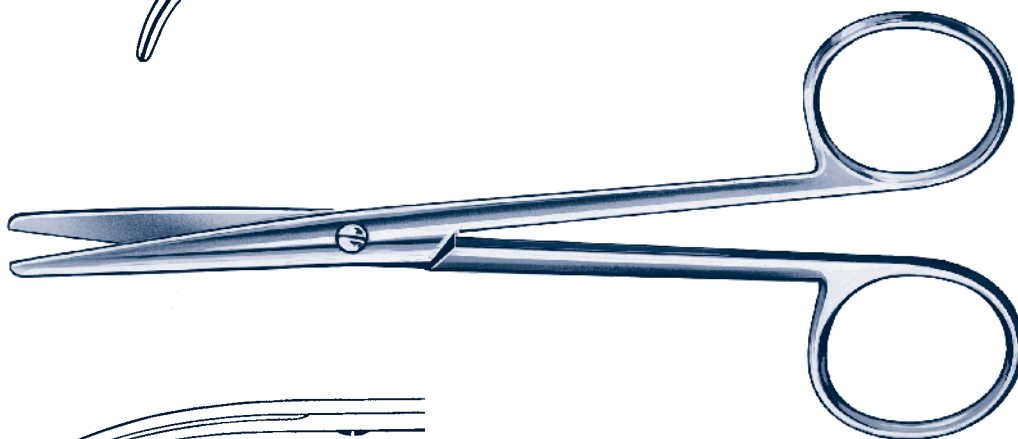

**SA60-4865-03**

13 cm

leicht gebogen  
slightly curved  
légèrement courbe  
ligeramente curvo



**SA60-4867-03**

13 cm

mittel gebogen  
medium curved  
moyennement courbe  
medio curvo



**SA60-4869-03**

13 cm

stark gebogen  
strong curved  
très courbe  
muy curvo

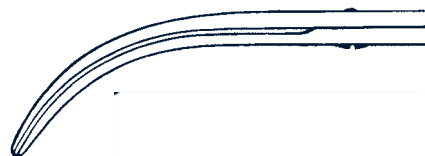

**SA60-4879-03**

11,5 cm

für Kinder  
for children  
pour enfants  
para niños

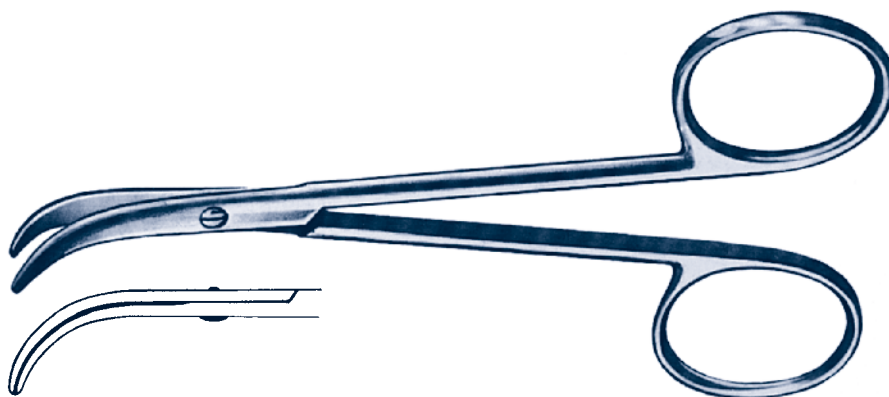



VITREKTOMIE-ZÄNGCHEN | VITREORETINAL FORCEPS

6 mm Griffstück | 6 mm handle | 20G=0,9 mm/23G=0,6 mm/25G=0,5 mm



**SA60-4920-00**  
FASSZANGE, GERIEFT, 20G  
GRASPING FORCEPS, SERRATED TIPS, 20G

**SA60-4920-00-23**  
FASSZANGE, GERIEFT, 23G  
GRASPING FORCEPS, SERRATED TIPS, 23G



**SA60-4921-00**  
FASSZANGE, GLATT, 45°, 20G  
GRASPING FORCEPS, SMOOTH, 45°, 20G



**SA60-4922-00**  
FASSZANGE, GLATT, 20G  
GRASPING FORCEPS, SMOOTH, 20G



**SA60-4922-00-23**  
FASSZANGE, GLATT, 23G  
GRASPING FORCEPS, SMOOTH, 23G



**SA60-4923-00**  
FASSZANGE, GERIEFT, 30°, 20G  
GRASPING FORCEPS, SERRATED TIPS, 30°, 20G



**SA60-4925-00**  
FASSZANGE, 1 X2 ZÄHNE, 20G  
GRASPING FORCEPS, 1 X2 TEETH, 20G

**SA60-4926-00**  
FASSZANGE, FASSFLÄCHEN AN DEN SPITZEN  
0,44 MM, 20G  
GRASPING FORCEPS, GRIP TIPS 0.44 MM, 20G

**SA60-4926-00-23**  
FASSZANGE, FASSFLÄCHEN AN DEN SPITZEN  
0,44 MM, 23G  
GRASPING FORCEPS, GRIP TIPS 0.44 MM, 23G

**SA60-4926-00-25**  
FASSZANGE, FASSFLÄCHEN AN DEN SPITZEN  
0,44 MM, 25G  
GRASPING FORCEPS, GRIP TIPS 0.44 MM, 25G



**SA60-4927-00**  
FASSZANGE, GLATT, 45°, 20G  
GRASPING FORCEPS, SMOOTH, 45°, 20G

**SA60-4927-00-23**  
FASSZANGE, GLATT, 45°, 23G  
GRASPING FORCEPS, SMOOTH, 45°, 23G



**SA60-4928-00**  
FASSZANGE, GLATT, 60°, 20G  
GRASPING FORCEPS, SMOOTH, 60°, 20G

**SA60-4928-00-23**  
FASSZANGE, GLATT, 60°, 23G  
GRASPING FORCEPS, SMOOTH, 60°, 23G



**SA60-4929-00**  
FASSZANGE, GERIEFT, 60°, 20G  
GRASPING FORCEPS, SERRATED TIPS, 60°, 20G

**SA60-4929-00-23**  
FASSZANGE, GERIEFT, 60°, 23G  
GRASPING FORCEPS, SERRATED TIPS, 60°, 23G



**SA60-4930-00**  
FASSZANGE, GERIEFT, 90°, 20G  
GRASPING FORCEPS, SERRATED TIPS, 90°, 20G

**SA60-4930-00-23**  
FASSZANGE, GERIEFT, 90°, 23G  
GRASPING FORCEPS, SERRATED TIPS, 90°, 23G



**SA60-4931-00**  
LÖFFELZANGE, 20G  
SPOON FORCEPS, 20G



**SA60-4958-00**  
FASSZANGE, GERIEFT, 20G  
GRASPING FORCEPS, SERRATED TIPS, 20G

**SA60-4958-00-23**  
FASSZANGE, GERIEFT, 23G  
GRASPING FORCEPS, SERRATED TIPS, 23G



VITREKTOMIE-ZÄNGCHEN | VITREORETINAL FORCEPS

6 mm Griffstück | 6 mm handle | 20G=0,9 mm/23G=0,6 mm/25G=0,5 mm



**SA60-4959-00**  
 FASSZANGE, INNEN DIAMANTBESCHICHTET, 20G  
 GRASPING FORCEPS, DIAMOND COATED INSIDE, 20G



**SA60-4973-00**  
 FASSZANGE, 20G  
 GRASPING FORCEPS, 20G

**SA60-4960-00**  
 FASSZANGE, FASSFLÄCHEN AN DEN SPITZEN 0,3 MM, 20G  
 GRASPING FORCEPS, GRIP TIPS 0.3 MM, 20G

**SA60-4977-00**  
 FASSZANGE, FASSFLÄCHEN AN DEN SPITZEN 0,3 MM, SCHAFT GEBOGEN, 20G  
 GRASPING FORCEPS, GRIP TIPS 0.3 MM, CURVED SHAFT, 20G



**SA60-4960-00-23**  
 FASSZANGE, FASSFLÄCHEN AN DEN SPITZEN 0,3 MM, 23G  
 GRASPING FORCEPS, GRIP TIPS 0.3 MM, 23G



**SA60-4977-00-23**  
 FASSZANGE, FASSFLÄCHEN AN DEN SPITZEN 0,3 MM, SCHAFT GEBOGEN, 23G  
 GRASPING FORCEPS, GRIP TIPS 0.3 MM, CURVED SHAFT, 23G

**SA60-4960-55**  
 FASSZANGE, MIT SPALT AN DER SPITZE, 20G  
 GRASPING FORCEPS, GRIP TIPS, SMALL GAP, 20G

**SA60-4979-00**  
 FASSZANGE, KAPSULORHEXIS, SCHAFT 20° GEBOGEN, 20G  
 GRASPING FORCEPS, CAPSULORHEXIS, SHAFT 20° CURVED, 20G



**SA60-4961-00**  
 FASSZANGE, 45°, 20G  
 GRASPING FORCEPS, 45°, 20G



**SA60-4962-00**  
 FASSZANGE, GLATT, 90°, 20G  
 GRASPING FORCEPS, SMOOTH, 90°, 20G



**SA60-4962-00-23**  
 FASSZANGE, GLATT, 90°, 23G  
 GRASPING FORCEPS, SMOOTH, 90°, 23G

**SA60-4963-00**  
 FASSZANGE, GLATT, 45°, 20G  
 GRASPING FORCEPS, SMOOTH, 45°, 20G



**SA60-4963-00-23**  
 FASSZANGE, GLATT, 45°, 23G  
 GRASPING FORCEPS, SMOOTH, 45°, 23G

**SA60-4966-00**  
 FASSZANGE, GERIEFT, 20G  
 GRASPING FORCEPS, SERRATED TIPS, 20G





## GLASKÖRPERSCHEREN | VITREORETINAL SCISSORS

6 mm Griffstück | 6 mm handle | 20G=0,9 mm/23G=0,6 mm/25G=0,5 mm



### SA60-4932-00

HEIMANN  
SCHERE, KNIEGEBOGEN, 90°, 20G  
SCISSORS, ANGLED SIDEWAYS, 90°, 20G



### SA60-4954-00

SCHERE, GEWINKELT, 30°, 20G  
SCISSORS, ANGLED, 30°, 20G

### SA60-4952-00

SCHERE, RUNDGEBOGEN, 20G  
SCISSORS, CURVED, 20G



### SA60-4956-00

SCHERE MIT SCHIPPE, GEWINKELT, 60°, 20G  
SCISSORS WITH SCOOP TIP, ANGLED, 60°, 20G



### SA60-4952-00-23

SCHERE, RUNDGEBOGEN, 23G  
SCISSORS, CURVED, 23G

### SA60-4957-00

HEIMANN  
SCHERE, GERADE, 20G  
SCISSORS, STRAIGHT, 20G

### SA60-4952-00-25

SCHERE, RUNDGEBOGEN, 25G  
SCISSORS, CURVED, 25G



### SA60-4957-00-23

HEIMANN  
SCHERE, GERADE, 23G  
SCISSORS, STRAIGHT, 23G

### SA60-4953-00

HEIMANN  
SCHERE, KNIEGEBOGEN, 60°, 20G  
SCISSORS, ANGLED SIDEWAYS, 60°, 20G



### SA60-4953-00-23

HEIMANN  
SCHERE, KNIEGEBOGEN, 60°, 23G  
SCISSORS, ANGLED SIDEWAYS, 60°, 23G



**VITREKTOMIE-ZÄNGCHEN | VITREORETINAL FORCEPS**

6 mm Griffstück aus Titan | 6 mm titanium handle | 20G = 0,9 mm / 23G = 0,6 mm / 25G = 0,5 mm



**SA60-4920-50**  
FASSZANGE, GERIEFT, 20G  
GRASPING FORCEPS, SERRATED TIPS, 20G



**SA60-4920-50-23**  
FASSZANGE, GERIEFT, 23G  
GRASPING FORCEPS, SERRATED TIPS, 23G



**SA60-4921-50**  
FASSZANGE, GLATT, 45°, 20G  
GRASPING FORCEPS, SMOOTH, 45°, 20G



**SA60-4922-50**  
FASSZANGE, GLATT, 20G  
GRASPING FORCEPS, SMOOTH, 20G



**SA60-4922-50-23**  
FASSZANGE, GLATT, 23G  
GRASPING FORCEPS, SMOOTH, 23G



**SA60-4923-50**  
FASSZANGE, GERIEFT, 30°, 20G  
GRASPING FORCEPS, SERRATED TIPS, 30°, 20G



**SA60-4925-50**  
FASSZANGE, 1 X2 ZÄHNE, 20G  
GRASPING FORCEPS, 1 X2 TEETH, 20G

**SA60-4926-50**  
FASSZANGE, FASSFLÄCHEN AN DEN SPITZEN  
0,44 MM, 20G  
GRASPING FORCEPS, GRIP TIPS 0.44 MM, 20G

**SA60-4926-50-23**  
FASSZANGE, FASSFLÄCHEN AN DEN SPITZEN  
0,44 MM, 23G  
GRASPING FORCEPS, GRIP TIPS 0.44 MM, 23G

**SA60-4926-50-25**  
FASSZANGE, FASSFLÄCHEN AN DEN SPITZEN  
0,44 MM, 25G  
GRASPING FORCEPS, GRIP TIPS 0.44 MM, 25G



**SA60-4927-50**  
FASSZANGE, GLATT, 45°, 20G  
GRASPING FORCEPS, SMOOTH, 45°, 20G



**SA60-4927-50-23**  
FASSZANGE, GLATT, 45°, 23G  
GRASPING FORCEPS, SMOOTH, 45°, 23G



**4928-50**  
FASSZANGE, GLATT, 60°, 20G  
GRASPING FORCEPS, SMOOTH, 60°, 20G



**SA60-4928-50-23**  
FASSZANGE, GLATT, 60°, 23G  
GRASPING FORCEPS, SMOOTH, 60°, 23G



**SA60-4929-50**  
FASSZANGE, GERIEFT, 60°, 20G  
GRASPING FORCEPS, SERRATED TIPS, 60°, 20G



**SA60-4929-50-23**  
FASSZANGE, GERIEFT, 60°, 23G  
GRASPING FORCEPS, SERRATED TIPS, 60°, 23G

**SA60-4930-50**  
FASSZANGE, GERIEFT, 90°, 20G  
GRASPING FORCEPS, SERRATED TIPS, 90°, 20G

**SA60-4930-50-23**  
FASSZANGE, GERIEFT, 90°, 23G  
GRASPING FORCEPS, SERRATED TIPS, 90°, 23G

**SA60-4931-50**  
LÖFFELZANGE, 20G  
SPOON FORCEPS, 20G

**SA60-4958-50**  
FASSZANGE, GERIEFT, 20G  
GRASPING FORCEPS, SERRATED TIPS, 20G

**SA60-4958-50-23**  
FASSZANGE, GERIEFT, 23G  
GRASPING FORCEPS, SERRATED TIPS, 23G



## VITREKTOMIE-ZÄNGCHEN | VITREORETINAL FORCEPS

6 mm Griffstück aus Titan | 6 mm titanium handle | 20G=0,9 mm/23G=0,6 mm/25G=0,5 mm



### SA60-4959-50

FASSZANGE, INNEN DIAMANTBESCHICHTET,  
20G  
GRASPING FORCEPS, DIAMOND COATED IN-  
SIDE, 20G



### SA60-4960-50

FASSZANGE, FASSFLÄCHEN AN DEN SPITZEN  
0,3 MM, 20G  
GRASPING FORCEPS, GRIP TIPS 0.3 MM, 20G



### SA60-4960-50-23

FASSZANGE, FASSFLÄCHEN AN DEN SPITZEN  
0,3 MM, 23G  
GRASPING FORCEPS, GRIP TIPS 0.3 MM, 23G

### SA60-4961-50

FASSZANGE, 45°, 20G  
GRASPING FORCEPS, 45°, 20G



### SA60-4962-50

FASSZANGE, GLATT, 90°, 20G  
GRASPING FORCEPS, SMOOTH, 90°, 20G

### SA60-4962-50-23

FASSZANGE, GLATT, 90°, 23G  
GRASPING FORCEPS, SMOOTH, 90°, 23G



### SA60-4963-50

FASSZANGE, GLATT, 45°, 20G  
GRASPING FORCEPS, SMOOTH, 45°, 20G

### SA60-4963-50-23

FASSZANGE, GLATT, 45°, 23G  
GRASPING FORCEPS, SMOOTH, 45°, 23G



### SA60-4966-50

FASSZANGE, GERIEFT, 20G  
GRASPING FORCEPS, SERRATED TIPS, 20G



### SA60-4973-50

FASSZANGE, 20G  
GRASPING FORCEPS, 20G



### SA60-4977-50

FASSZANGE, FASSFLÄCHEN AN DEN SPITZEN  
0,3 MM, SCHAFT GEBOGEN, 20G  
GRASPING FORCEPS, GRIP TIPS 0.3 MM, CUR-  
VED SHAFT, 20G

### SA60-4977-50-23

FASSZANGE, FASSFLÄCHEN AN DEN SPITZEN  
0,3 MM, SCHAFT GEBOGEN, 23G  
GRASPING FORCEPS, GRIP TIPS 0.3 MM, CUR-  
VED SHAFT, 23G



### SA60-4979-50

FASSZANGE, KAPSULORHEXIS, SCHAFT 20°  
GEBOGEN, 20G  
GRASPING FORCEPS, CAPSULORHEXIS,  
SHAFT 20° CURVED, 20G



## GLASKÖRPERSCHEREN | VITREORETINAL SCISSORS

6 mm Griffstück aus Titan | 6 mm titanium handle | 20G = 0,9 mm / 23G = 0,6 mm / 25G = 0,5 mm

**SA60-4932-50**

HEIMANN

SCHERE, KNIEGEBOGEN, 90°, 20G  
SCISSORS, ANGLED SIDEWAYS, 90°, 20G**SA60-4954-50**SCHERE, GEWINKELT, 30°, 20G  
SCISSORS, ANGLED, 30°, 20G**SA60-4952-50**SCHERE, RUNDGEBOGEN, 20G  
SCISSORS, CURVED, 20G**SA60-4956-50**SCHERE MIT SCHIPPE, GEWINKELT, 60°, 20G  
SCISSORS WITH SCOOP TIP, ANGLED, 60°, 20G**SA60-4952-50-23**SCHERE, RUNDGEBOGEN, 23G  
SCISSORS, CURVED, 23G**SA60-4957-50**HEIMANN  
SCHERE, GERADE, 20G SCISSORS,  
STRAIGHT, 20G**SA60-4952-50-25**SCHERE, RUNDGEBOGEN, 25G  
SCISSORS, CURVED, 25G**SA60-4957-50-23**HEIMANN  
SCHERE, GERADE, 23G SCISSORS,  
STRAIGHT, 23G**SA60-4953-50**

HEIMANN

SCHERE, KNIEGEBOGEN, 60°, 20G  
SCISSORS, ANGLED SIDEWAYS, 60°, 20G**SA60-4953-50-23**

HEIMANN

SCHERE, KNIEGEBOGEN, 60°, 23G  
SCISSORS, ANGLED SIDEWAYS, 60°, 23G



VITREKTOMIE-ZÄNGCHEN | VITREORETINAL FORCEPS

8 mm Kunststoff Griffstück | 8 mm plastic handle | 20G=0,9 mm/23G=0,6 mm/25G=0,5 mm



**SA60-4920P00**  
FASSZANGE, GERIEFT, 20G  
GRASPING FORCEPS, SERRATED TIPS, 20G



**SA60-4920P00-23**  
FASSZANGE, GERIEFT, 23G  
GRASPING FORCEPS, SERRATED TIPS, 23G



**SA60-4921P00**  
FASSZANGE, GLATT, 45°, 20G  
GRASPING FORCEPS, SMOOTH, 45°, 20G



**SA60-4922P00**  
FASSZANGE, GLATT, 20G  
GRASPING FORCEPS, SMOOTH, 20G



**SA60-4922P00-23**  
FASSZANGE, GLATT, 23G  
GRASPING FORCEPS, SMOOTH, 23G



**SA60-4923P00**  
FASSZANGE, GERIEFT, 30°, 20G  
GRASPING FORCEPS, SERRATED TIPS, 30°, 20G

**SA60-4925P00**  
FASSZANGE, 1X2 ZÄHNE, 20G  
GRASPING FORCEPS, 1X2 TEETH, 20G

**SA60-4926P00**  
FASSZANGE, FASSFLÄCHEN AN DEN SPITZEN  
0,44 MM, 20G  
GRASPING FORCEPS, GRIP TIPS 0.44 MM, 20G

**SA60-4926P00-23**  
FASSZANGE, FASSFLÄCHEN AN DEN SPITZEN  
0,44 MM, 23G  
GRASPING FORCEPS, GRIP TIPS 0.44 MM, 23G

**SA60-4926P00-25**  
FASSZANGE, FASSFLÄCHEN AN DEN SPITZEN  
0,44 MM, 25G  
GRASPING FORCEPS, GRIP TIPS 0.44 MM, 25G



**SA60-4927P00**  
FASSZANGE, GLATT, 45°, 20G  
GRASPING FORCEPS, SMOOTH, 45°, 20G



**SA60-4927P00-23**  
FASSZANGE, GLATT, 45°, 23G  
GRASPING FORCEPS, SMOOTH, 45°, 23G



**SA60-4928P00**  
FASSZANGE, GLATT, 60°, 20G  
GRASPING FORCEPS, SMOOTH, 60°, 20G



**SA60-4928P00-23**  
FASSZANGE, GLATT, 60°, 23G  
GRASPING FORCEPS, SMOOTH, 60°, 23G



**SA60-4929P00**  
FASSZANGE, GERIEFT, 60°, 20G  
GRASPING FORCEPS, SERRATED TIPS, 60°, 20G

**SA60-4929P00-23**  
FASSZANGE, GERIEFT, 60°, 23G  
GRASPING FORCEPS, SERRATED TIPS, 60°, 23G

**SA60-4930P00**  
FASSZANGE, GERIEFT, 90°, 20G  
GRASPING FORCEPS, SERRATED TIPS, 90°, 20G

**SA60-4930P00-23**  
FASSZANGE, GERIEFT, 90°, 23G  
GRASPING FORCEPS, SERRATED TIPS, 90°, 23G

**SA60-4931P00**  
LÖFFELZANGE, 20G  
SPOON FORCEPS, 20G



**SA60-4958P00**  
FASSZANGE, GERIEFT, 20G  
GRASPING FORCEPS, SERRATED TIPS, 20G

**SA60-4958P00-23**  
FASSZANGE, GERIEFT, 23G  
GRASPING FORCEPS, SERRATED TIPS, 23G



## VITREKTOMIE-ZÄNGCHEN | VITREORETINAL FORCEPS

8 mm Kunststoff Griffstück | 8 mm plastic handle | 20G = 0,9 mm / 23G = 0,6 mm / 25G = 0,5 mm



### SA60-4959P00

FASSZANGE, INNEN DIAMANTBESCHICHTET,  
20G  
GRASPING FORCEPS, DIAMOND COATED IN-  
SIDE, 20G



### SA60-4960P00

FASSZANGE, FASSFLÄCHEN AN DEN SPITZEN  
0,3 MM, 20G  
GRASPING FORCEPS, GRIP TIPS 0.3 MM, 20G

### SA60-4960P00-23

FASSZANGE, FASSFLÄCHEN AN DEN SPITZEN  
0,3 MM, 23G  
GRASPING FORCEPS, GRIP TIPS 0.3 MM, 23G



### SA60-4961P00

FASSZANGE, 45°, 20G  
GRASPING FORCEPS, 45°, 20G



### SA60-4962P00

FASSZANGE, GLATT, 90°, 20G  
GRASPING FORCEPS, SMOOTH, 90°, 20G

### SA60-4962P00-23

FASSZANGE, GLATT, 90°, 23G  
GRASPING FORCEPS, SMOOTH, 90°, 23G



### SA60-4963P00

FASSZANGE, GLATT, 45°, 20G  
GRASPING FORCEPS, SMOOTH, 45°, 20G

### SA60-4963P00-23

FASSZANGE, GLATT, 45°, 23G  
GRASPING FORCEPS, SMOOTH, 45°, 23G



### SA60-4966P00

FASSZANGE, GERIEFT, 20G  
GRASPING FORCEPS, SERRATED TIPS, 20G



### SA60-4973P00

FASSZANGE, 20G  
GRASPING FORCEPS, 20G



### SA60-4977P00

FASSZANGE, FASSFLÄCHEN AN DEN SPITZEN  
0,3 MM, SCHAFT GEBOGEN, 20G  
GRASPING FORCEPS, GRIP TIPS 0.3 MM, CUR-  
VED SHAFT, 20G

### SA60-4977P00-23

FASSZANGE, FASSFLÄCHEN AN DEN SPITZEN  
0,3 MM, SCHAFT GEBOGEN, 23G  
GRASPING FORCEPS, GRIP TIPS 0.3 MM, CUR-  
VED SHAFT, 23G



### SA60-4979P00

FASSZANGE, KAPSULORHEXIS, SCHAFT 20°  
GEBOGEN, 20G  
GRASPING FORCEPS, CAPSULORHEXIS,  
SHAFT 20° CURVED, 20G



## GLASKÖRPERSCHEREN | VITREORETINAL SCISSORS

8 mm Kunststoff Griffstück | 8 mm plastic handle | 20G=0,9 mm/23G=0,6 mm/25G=0,5 mm



### SA60-4932P00

HEIMANN  
SCHERE, KNIEGEBOGEN, 90°, 20G  
SCISSORS, ANGLED SIDEWAYS, 90°, 20G



### SA60-4954P00

SCHERE, GEWINKELT, 30°, 20G  
SCISSORS, ANGLED, 30°, 20G



### SA60-4952P00

SCHERE, RUNDGEBOGEN, 20G  
SCISSORS, CURVED, 20G



### SA60-4956P00

SCHERE MIT SCHIPPE, GEWINKELT, 60°, 20G  
SCISSORS WITH SCOOP TIP, ANGLED, 60°, 20G

### SA60-4952P00-23

SCHERE, RUNDGEBOGEN, 23G  
SCISSORS, CURVED, 23G

### SA60-4957P00

HEIMANN  
SCHERE, GERADE, 20G SCISSORS,  
STRAIGHT, 20G

### SA60-4952P00-25

SCHERE, RUNDGEBOGEN, 25G  
SCISSORS, CURVED, 25G



### SA60-4957P00-23

HEIMANN  
SCHERE, GERADE, 23G SCISSORS,  
STRAIGHT, 23G



### SA60-4953P00

HEIMANN  
SCHERE, KNIEGEBOGEN, 60°, 20G  
SCISSORS, ANGLED SIDEWAYS, 60°, 20G

### SA60-4953P00-23

HEIMANN  
SCHERE, KNIEGEBOGEN, 60°, 23G  
SCISSORS, ANGLED SIDEWAYS, 60°, 23G

**SA60-5906-00**  
LISTER  
18 cm

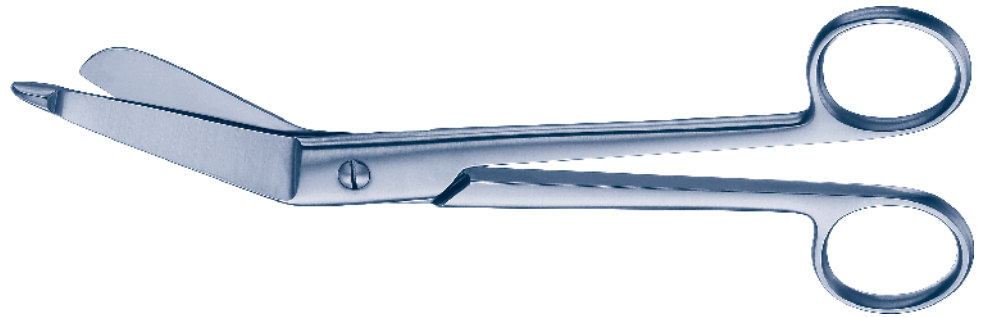

**SA60-5908-00**  
LISTER  
20 cm

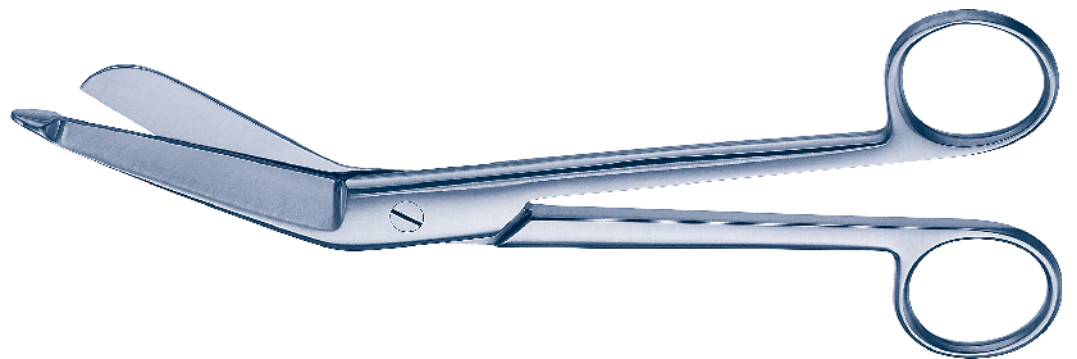

	Seite
<b>A</b>	
ADSON, Pinzetten	69
AEBLI, Federschere	145
AGRICOLA, Tränensackspreizer	16
ALFONSO, Sperrelevator	15
ALVIS	
Fremdkörperkürette	50
Anatomische Pinzetten	68
ANEL, Kanülen	115
ANIS, Kernmanipulator	31
ARLT, Schlinge	55
ARRUGA	
Kapselpinzette	82
Nadelhalter	100
Starhaken	23
ARRUGA-KIRBY, Kapselpinzette	82
ARRUGA-NIZETIC, Kapselpinzette	82
ATKINSON, Kanülen	116
AUBARET	
Tränensackhäkchen	20
Augenskalpell	36
AXENFELD, Tränensackhäkchen	20
AXENFELD (KNAPP), Tränensackhäkchen	20
AYER, Chalazionspinzette	90
<b>B</b>	
BACKHAUS, Tuchklemme	60
BAIRD, Chalazionspinzette	90
BANGERTER	
Irisspatel	48
Muskelklemme	88
BARRAQUER	
Cilienpinzette	91
Fadenlöspinzette	97
Fixierpinzette	84
Hornhautscheren	143
Iridektomieschere	130
Irisspatel	49
Klingenhalter	113
Nadelhalter	100 ff
Vorderkammerpinzette	92
BARRAQUER MINIATUR, Federschere	137
BARRAQUER-OOSTERHUIS	
Sperrelevatoren	11
BECHERT, Linsenkernrotierer	30
BECHERT-MCPHERSON, Fadenpinzette	94
BEER, Cilienpinzette	91
BERKE, Muskelpinzette	88
BEYER, Knochenstanze	63
Bindehautpinzetten	82
BISHOP-HARMON, Irispinzetten	74
BLASCOVIC, Muskelpinzette	88
BONACCOLTO, Pinzette für Schiel-OP	85
BONN	
Mikropinzette	71
Kanülen	116
Irishäkchen	19
Schielhäkchen	22
BONN-MCPHERSON	
Fadenpinzette	94
Mikropinzette	71
Nahtpinzette	81
BONNER MODELL	
Augenschere	153
Mikropinzette	70
Nahtpinzette	95
BORES	
Doppelkornealpinzette	83
Markierinstrument	66
BOWMAN	
Diszissionsnadel	41
Tränenkanalsonde	57

	Seite
BRAUWEILER	
Kanülen	116
Saughandgriff	122
BUNGE, Excentertationslöffel	55
BURATTO	
IOL Pinzette	78 f
LASIK Flap Pinzette	80
Lasik Flap Protektor	45
<b>C</b>	
CARTER, Einführinstrument	45
CASTROVIEJO	
Cyclodialysespatel	48
Dilatator	59
Doppelspatel	53
Fadenpinzette	93
Federschere	141
Fixierpinzette	83
Hornhautschere	144 ff
Kanülen	117
Keratoplastikscherer	138, 145
Klingenhalter	113
Nahtpinzette	93
Nadelhalter	101 ff
Synechia-Schere	146
Sperrelevatoren	5
Zirkel	65
CASTROVIEJO MICRO-MINIATUR	
Hornhautschere	142 ff
Trephe	64
CASTROVIEJO-KALT, Nadelhalter	100
CASTROVIEJO-KOSHIMA, Nadelhalter	108
CASTROVIEJO-VANNAS	
Vannas-artige Schere	133
CASTROVIEJO-WARING	
Fixierpinzette	69
CAUER, Chalazionspinzette	90
Chalazionspinzetten	90
CHANG, Phako Chopper	32
Chirurgische Pinzetten	68
Cilienpinzetten	91
CITELLI, Knochenstanze	63
CLARK, Sperrelevatoren	8
CLAYMAN	
IOL-Häkchen	21
Linsenhäkchen	24
Linsenimplantationspinzette	80
Linsenkernrotierer	30
COLIBRI, Nahtpinzetten	96 f
COLIBRI-TROUTMAN, Nahtpinzette	96
COOK, Sperrelevatoren	13
CORYDON, Kapsulorhexis-Pinzette	77
<b>D</b>	
DARDENNE,	
Irishäkchen	25, 41
Satomesser	38
DAVIEL, Starlöffel	53
DERMOT-PIERSE, Pinzette	70
DESMARRES	
Chalazionspinzette	90
Lidhalter	17
Diamantmesser	36
Dilatatoren	59
DIX, Fremdkörper-Doppelinstrument	52
DODEN, Linsenimplantationspinzette	80
DODICK, Kernspalt-Pinzette	82
Doppelinstrumente	52
DRAEGER, Bindehautpinzette	82
DRYSDALE,	
Kernmanipulator und Kapselpolierer	33

	Seite
<b>E</b>	
ELSCHNIG	
Cyclodialysespatel	48
Pinzette für Schiel-OP	85
ELZE, Irispinzette	69
ENGLISCHES MODELL, Nahtpinzette	98
Entropionspinzetten	88
Erukleationsschere	158
<b>F</b>	
Fadenschere	157
Federschere für Mikro-Chirurgie	136 ff
FENZL, Linsenmanipulator	27
FINE-THORTON, Fixierring	67
Fixierpinzetten	83
Fixierringe	67
FLYNN, Sklera-Lokalisator	56
FRANCIS, Fremdkörpermesser	37
FREER, Elevatorium	42
Fremdkörperinstrumente	50
Fremdkörperschlinge und -magnet	51
FUKASAKU, Häkchen	33
<b>G</b>	
GASKIN, Fragmentpinzette	79
GASS	
Gefässklemmen	60
Häkchen	23
Stanze	62
GIANETTI	
Kapsulorhexis-Pinzetten	75
GIESSEN, Markierinstrument	65
GILL	
Hornhautmesser	37
Vannas-artige Schere	133
GILLS-VANNAS, Kapselschere	135
GILLS-WELSH	
Vannas-artige Schere	133
GINSBERG, Sperrelevator	3
Glaskörperschere	159 ff
Glaskörperzängchen	159 ff
Golf CLUB, Fremdkörpermesser	36
GRADLE, Cilienpinzette	91
GRAEFE	
Augenschere	155
Fixierpinzette	83
Irishäkchen	19
Schielhäkchen	21
Skleramesser	36
Starmesser	37
GRAEFE (WALTER)	
Augenschere	155
GRAETHER, Irisretractor	31
GREEN	
Doppelspatel	53
Fixierpinzette	84
Schielhäkchen	22
GUTHRIE, Doppelhäkchen	19
<b>H</b>	
HÄFLIGER, Kernspalter	35
HALSTED-MOSQUITO, Arterienklemme	61
HAMBURG	
Irispinzetten	74
Luftlanze	39
HARMS, Trabekularsonde	58
HARTMANN-MOSQUITO, Arterienklemmen	61
HATA, Muskelpinzette	86
HEALON, Kanülen	115
HEIDELBERG, Irispinzetten	73

	Seite
HEIDELBERGER MODELL	
Cilienpinzette	92
Strabismusscheren	150
HEIMANN, Glaskörperscheren	168
HELVESTON	
Häkchen	23
Retraktor	45
HENRY, Cilienpinzette	91
HERBA, Chalazionslöffel	54
HESS, Irispinzetten	74
HIRSCHMANN, Linsen-Spatel	26
HOFFER, Markierinstrument	66
HOFFMANN	
Kernspalter und Linsenkernrotierer	29
HOLTH, Stanze	62
HUNT, Chalazionspinzette	90
Hydro Chopper	40
<b>I</b>	
I. O. L.-Instrumente	24
Implantationspinzetten	81
INAMURA, Kapsulorhexis-Pinzetten	75 ff
Iridektomiescheren	131
Irismesser	42
Irispinzetten	68 ff
<b>J</b>	
JACOBI, Repositionshäkchen	32
JAECKER, Fadenlösmesser	41
JAEGER	
Lanzennmesser	39
Lidplatte	18
Schielhäkchen	21
JAFFE	
Lidhalter	18
Linsen-Spatel	26
JAFFE-KNOLLE, Iris-Häkchen	26
JAMESON,	
Muskelpinzette	87
Schielhäkchen	22
JESS, Fixierpinzette	83
JOHN HOPKINS, Gefäßklemme	60
JONES, Tuchklemme	60
<b>K</b>	
KAGAWA, Nukleusspalter	25
KALT, Nadelhalter	100
KANSAS, Fragmentpinzette	79
Kapselscheren	135
Kapsulorhexis-Pinzetten	75
KATZIN, Hornhautscheren	140
KELLY, Stanze	62
KELMAN, Mikro-Pinzette	81
KELMAN-McPHERSON, Mikro-Pinzette	81
Keratoplastik Siebspatel	46
KERSHNER, Sperrelevatoren	3
KIMURA, Platin Spatel	45
KIRBY, Linsenschieber	53
Klemmen	60
Klingenhalter	113
KNAPP, Irismesser	42
Knochenstanzen	63
KNOLLE, Iris-Häkchen	26
KOCH	
Irisspatel	49
Federscheren für Mikro-Chirurgie	136
Manipulator	26
Nukleusspalter	31
KRATZ-BARRAQUER, Sperrelevator	14
KREISSIG, Kombideller	44
KREMER, Fixierpinzette	84
KUGLEN, Linsenmanipulator	24, 27

KUHNT	
Hornhautschaber	41
Kystotome	43
<b>L</b>	
Löffel	53
LAMBERT, Chalazionspinzette	90
LANCASTER, Sperrelevator	5
Lanzennmesser	39
LESTER	
IOL-Manipulator	28
Irispinzetten	74
LESTER-BURCH, Sperrelevatoren	6
LEWIS, Schlinge	56
LIEBERMANN	
Mikrofinger	32
Sperrelevatoren	1
LISTER, Enukleationsscheren	168
LIVERNOIS	
Linsenhaltelinzette	78
Aufnahme- und Faltpinzette	79
LORDAN, Chalazionspinzette	90
LUND, Irishäkchen	31
LUNTZ-DODICK, Stanze	62
<b>M</b>	
MACKENSEN, Keratoplastikscheren	148
MALTZMAN-FENZL, Linsenmanipulator	34
Markierinstrumente	65
MASKET, Kapsulorhexis-Pinzetten	75, 77
MAUMENEE-PARK, Sperrelevatoren	9
Mc GUIRE	
Augenscheren	156
Federscheren für Mikro-Chirurgie	138
McCULLOUGH, Pinzetten für Schiel-OP	85
McDONALD, IOL Pinzette	79
McINTYRE, Sperrelevatoren	15
McPHERSON	
Fadenpinzette	95
IOL Pinzette	80
Mikropinzette	71
MELLINGER, Sperrelevatoren	4
MELLINGER-BEARD, Sperrelevatoren	4
MELLINGER-GIMBLE, Sperrelevatoren	4
MEYER, Fremdkörper-Hohlmeißel	50
MEYER-SCHWICKERATH, Lokalisator	65
MEYHÖFER, Chalazionslöffel	54
MODELL FRANKFURT, Irisspatel	46
MODELL GIESSEN	
Tränenwegsonde	59
Wundspatel und Retraktor	46
MODELL HEIDELBERG	
Elevatorium	42
Rasparatorium	42
MODELL TUEBINGEN	
Fadenpinzette	93 f
Vannas-artige Scheren	133
MOORFIELD, Nahtpinzette	95
MUELLER, Tränensackspreizer	16
MULDOON, Dilator	59
Muskelpinzetten	86
<b>N</b>	
NAGAHARA	
Nucleus Chopper	34
Linsenspatel	33
Spülhandgriff	40
Nahtpinzetten	93 ff
NEUHANN	
Fixierring	67
Irishäkchen, Kernspalter	29
Kernspalter und Linsenspatel	29

Linsenkernrotierer	30
Linsenkernrotierer und Kernspalter	29
NEW ORLEANS, Schlinge	56
Noppenmatten	124
NOYES, Iridektomiescheren	129
<b>O</b>	
O'CONNOR, Lokalisator	65
ONG, Kapselscheren	135
OSHER, Linsenschneider	138
OSHER-NEUMANN, Markierinstrument	66
<b>P</b>	
PARK-GUYTON, Sperrelevatoren	9
PATON, Skleramesser	37
PAUFIQUE, Nahtpinzette	94
PFAEFFL, Femtoflapflifer	25
Phako- und Irisspatel	49
Phako-Lanze	39
Pinzetten für Skleranägel	92
Pinzetten	92
Pinzetten für Mikro-Chirurgie	69
Pinzetten für Schieloperation	85
PISACANO, Linsenkernrotierer	33
PLANGE	
Fremdkörperheber	51
Fremdkörper-Doppelinstrument	52
POLACK, Doppelkornealpinzette	82
PRINCE, Muskelpinzette	86
<b>R</b>	
R. KOCH, Spülhandgriff	40
RAININ, Kanülen	115
RANDOLPH, Kanülen	117
REMKY	
Pinzette	70
Zügelnahtpinzette	84
RENTSCH, Linsenmanipulator	34
ROLLET	
Tränensackhäkchen	20
Meißel	43
ROSEN	
Nukleusspalter	31
Spülhandgriff	40
RUEDEMANN, Dilator	59
<b>S</b>	
SATO, Hornhautmesser	38
Satomesser	38
SÄTTLER, Muskelpinzette	86
SAUPE, Cilienpinzette	92
SAUTTER, Kanülen	115
SCHEPENS	
Orbitalspatel	17
Skleral Depressor	44
SCHIOETZ, Tonometer	112
Schlingen	56
SCHOCKET, Skleral Depressor	44
SCHOTT, Sperrelevatoren	12
SCHWEIZER MODELL	
Cilienpinzette	91
Fremdkörpernadel	50
Trepshin	64
Sehnenscheren	147 ff
SHAAF, Fremdkörperpinzette	92
SHEETS, Kanülen	117
SHEPARD	
Kanülen	117
Linsenimplantationspinzette	80
SINSKEY, Linsenhäkchen	24, 27
Skalpelli	114

	Seite
Skleral Depressor	44
<b>SNELLEN</b>	
Entropionspinzette	89
Schlinge	56
Spülhandgriffe	122
SPALECK, Linsenimplantationspinzette	78
Spatel	45 f
SPEEMANN, Fremdkörperpinzette	92
SPENCER, Fadenschere	157
ST. MARTIN, Nahtpinzette	95
Stanzen	62
Starmesser	37
STEINMETZ, Spatel	25
Sterilisierbehälter	123
<b>STEVENS</b>	
Kanülen	117
Sehnenscheren	148 f
Linsenhäkchen	22
STEVENSON, Tränensackspreizer	16
Strabismusscheren	150 f
<b>T</b>	
TEARSE, Meibom Pinzette	89
<b>TENNANT</b>	
Fadenpinzetten	69, 95
Lidhalter	18
THORLAKSON, Sperrelevator	3
<b>THORNTON</b>	
Markierinstrument	66
Fixierring	67
TOOKE, Hornhautmesser	36
Tränensackspreizer	16
Trephine	64
<b>TROUTMAN</b>	
Hornhautscheren	139
Kanülen	116
Klingenhalter	113
Linsenspatel	46
Mikro-Irisspatel	48
Nadelhalter	108
Schlinge	56
Zügelnahtpinzette	84
TYRELL, Irishäkchen	19
<b>U</b>	
URIBE-STERN, Kapselschere	135
UTRATA, Kapsulorhexis-Pinzetten	75 ff
<b>V</b>	
<b>VANNAS</b>	
Kapselschere	135
Scheren	131 ff
Vannas-artige Scheren	133 f
Vannas-artige Scheren	133 f
Vitrektomie Scheren	159 ff
Vitrektomie Zängchen	159 ff
<b>W</b>	
WATZKE, Spreizpinzette	88
WEBER, Schlinge	55
<b>WECKER</b>	
Iridektomiescheren	130
Irisspatel	47
WEISS, Sperrelevatoren	4, 6
WELLS, E nukleationslöffel	55
<b>WEST</b>	
Flachmeissel	43
Hohlmeissel	43
WESTCOTT, Sehnenscheren	147 f
WESTCOTT (Mc PHERSON)	

	Seite
Federscheren für Mikro-Chirurgie	138
<b>WHEELER</b>	
Diszissionsnadel	41
Doppelspatel	52
<b>WILDER (NETTLESHIP)</b>	
Tränenweg-Dilatator	59
WILLIAMS, Sperrelevatoren	14
WILMER, Augenschere	155
WORST, Pigtaillsonde	58
WORTH, Muskelpinzette	87
<b>Z</b>	
ZIEGLER, Irismesser	42
Zirkel	65
ZUERCHER MODELL, Nahtpinzette	97

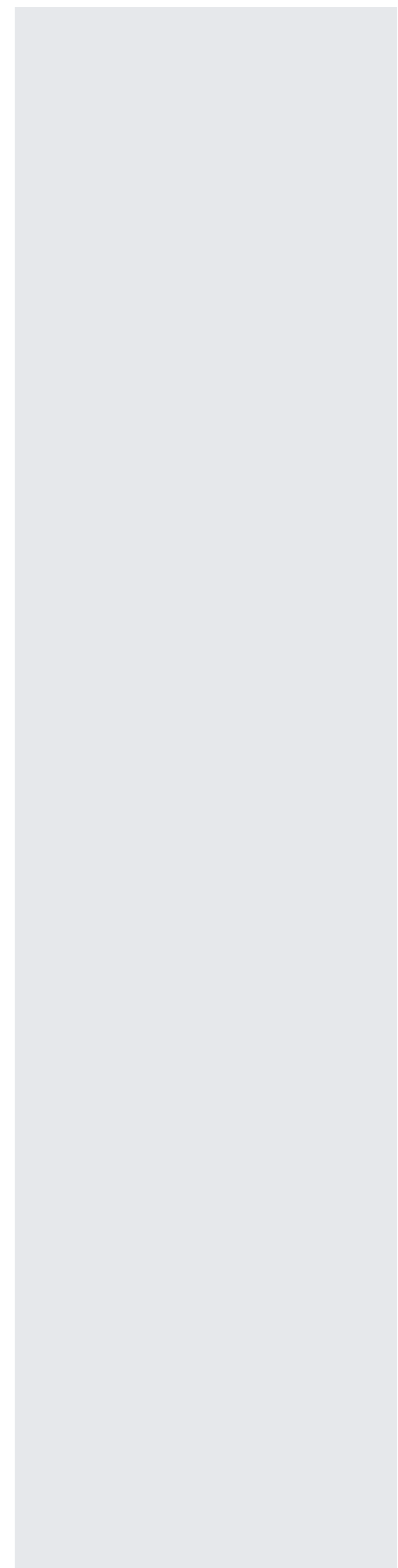

Page

**A**

ADSON, Forceps	69
Advancement forceps	86
AEBLI, Spring Handle Scissors	145
AGRICOLA, Lacrimal sac retractor	16
ALFONSO, Eye specula	15
ALVIS	
Anatomical forceps	68
Foreign body instrument	50
ANEL, Cannulas	115
ANIS, Nucleus manipulator	31
ARLT, Loop	55
ARRUGA	
Capsule forceps	82
Extraction hook	23
Needleholders	100
ARRUGA-KIRBY, Capsule forceps	82
ARRUGA-NIZETIC, Capsule forceps	82
ATKINSON, Cannulas	116
AUBARET	
Eye scalpel	36
Hook for lacrimal sack	20
AXENFELD, Hook for lacrimal sack	20
AXENFELD (KNAPP)	
Hook for lacrimal sack	20
AYER, Chalazion forceps	90

**B**

BACKHAUS, Towel clamp	60
BAIRD, Chalazion forceps	90
BANGERTER	
Iris spatula	48
Muscle clamp	88
BARRAQUER	
Cilia forceps	91
Corneal scissors	143
Fixation forceps	84
Iris scissors	130
Iris spatula	49
Needleholders	100 ff
Razor Blade holder	113
Secondary membrane forceps	92
Suture removal forceps	97
BARRAQUER MINIATUR,	
Spring handle scissors	137
BARRAQUER-OOSTERHUIS	
Retractors	11
BECHERT, Lens nucleus rotator	30
BECHERT-MCPHERSON, Suture forceps	94
BEER, Cilia forceps	91
BERKE, Muscle forceps	88
BEYER, Punch	63
Conjunctival forceps	82
BISHOP-HARMON, Iris forceps	74
BLASCOVIC, Muscle forceps	88
BONACCOLTO, Strabismus forceps	85
BONN	
Cannulas	116
Forceps micro-surgery	71
Iris hooks	19
Strabismus hook	22
BONN-McPHERSON	
Forceps micro-surgery	71
Suture forceps	81
Tying forceps	94
BONNER MODELL	
Eye scissors	153
Forceps micro-surgery	70
Suture forceps	95
BORES	
Corneal suturing forceps	83
Marking instrument	66

**BOWMAN**

Dicission needle	41
Lacrimal probe	57
BRAUWEILER	
Aspirating handpiece	122
Cannulas	116
BUNGE, Exenteration spoon	55
BURATTO	
IOL-forceps	78 f
Lasik flap forceps	80
Lasik flap protector	45

**C**

Caliper	65
Capsule scissors	135
Capsulorhexis-forceps	75
CARTER, Introducer	45
CASTROVIEJO	
Caliper	65
Cannulas	117
Corneal scissors	139 ff
Cyclodialysis spatula	48
Dilators	59
Double ended spatula	53
Fixation forceps	83
Keratoplasty scissors	138, 144 f
Needleholders	101 ff
Razor Blade holder	113
Retractors	5
Spring handle scissors	138 ff
Suture forceps	93
Synchia-Schere	146
Tying forceps	93
CASTROVIEJO MICRO-MINIATUR	
Corneal scissors	142 ff
Trepines	64
CASTROVIEJO-KALT, Needleholders	100
CASTROVIEJO-KOSHIMA, Needleholders	108
CASTROVIEJO-VANNAS	
Vannas-type scissors	133
CASTROVIEJO-WARING	
Fixation forceps	69
Cataract knives	37
CAUER, Chalazion forceps	90
Chalazion forceps	90
CHANG, Phako Chopper	32
Cilia forceps	91
CITELLI, Punch	63
Clamps	60
CLARK, Retractors	8
CLAYMAN	
IOL-Hook	21
Lens hook	24
Lens nucleus rotator	30
Soft IOL inserting forceps	80
COLIBRI, Suture forceps	96 f
COLIBRI-TROUTMAN, Suture forceps	96
COOK, Retractors	13
CORYDON, Capsulorhexis-forceps	77
Cystotomes	43
<b>D</b>	
DARDENNE	
Iris hooks	25, 41
Sato knife	38
DAVIEL, Spoon	53
DERMOT-PIERSE, Micro-forceps	70
DESMARRES	
Chalazion forceps	90
Lid retractors	17
Diamond knives	36
Dilators	59
DIX, Foreign body instrument	52

Page

DODEN, Soft IOL inserting forceps	80
DODICK, Micro Nucleus Cracker	82
Double ended instruments	52
DRAEGER, Conjunctival forceps	82
DRYSDALE, Nucleus rotator	33

**E**

ELSCHNIG	
Cyclodialysis spatula	48
Strabismus forceps	85
ELZE, Iris forceps	69
ENGLISCHES MODELL, Suture forceps	98
Entropium forceps	88
Enucleation scissors	158

**F**

Spring handle scissors for Micro-Surgery	136 ff
FENZL, Lense manipulator	27
FINE-THORTON, Fixation ring	67
Fixation forceps	83
Fixation rings	67
FLYNN, Scleral depressor	56
FRANCIS, Foreign body forceps	37
FREER, Elevator	42
Forceps	92
Forceps for Micro-Surgery	69
Forceps for scleral plugs	92
Foreign body instruments	50
Foreign body loop and magnetic probe	51
FUKASAKU, Hook	33

**G**

GASKIN, Fragment forceps	79
GASS	
Hook	23
Punch	62
Serrefines	60
GIANETTI	
Capsulorhexis-forceps	75
GIESSEN, Marking instrument	65
GILL	
Corneal knife	37
Vannas-type scissors	133
GILLS-VANNAS, Capsule scissors	135
GILLS-WELSH	
Vannas-type scissors	133
GINSBERG, Eye specula	3
Golf CLUB, Foreign body spud	36
GRADLE, Cilia forceps	91
GRAEFE	
Cataract knife	37
Eye scissors	155
Fixation forceps	83
Iris hooks	19
Scarifier	36
Strabismus hook	21
GRAEFE (WALTER)	
Eye scissors	155
GRAETHER, Iris retractor	31
GREEN	
Double ended spatula	53
Fixation forceps	84
Strabismus hook	22
GUTHRIE, Fixation hook	19

**H**

HÄFLIGER, Nucleus manipulator	35
HALSTED-MOSQUITO, Mosquito forceps	61
HAMBURG	
Iris forceps	74
Keratome	39

Page

	Page		Page		Page
HARMS, Trabeculotomy probe	58	KREISSIG, Localizer	44	Lens nucleus rotator	30
HARTMANN-MOSQUITO		KREMER, Fixation forceps	84	Nucleus dividing hook and lens spatula	29
Mosquito forceps	61	KUGLEN, Lens manipulator	24, 27	Nucleus rotator and dividing hook	29
HATA, Advancement forceps	86	KUHNT		NEW ORLEANS, Lens loop	56
HEALON, Cannulas	115	Corneal scarifier	41	NOYES, Iris scissors	129
HEIDELBERG, Iris forceps	73				
HEIDELBERGER MODELL		<b>L</b>		<b>O</b>	
Cilia forceps	92	Lacrimal sac retractors	16	O'CONNOR, Localizer	65
Strabismus scissors	150	LAMBERT, Chalazion forceps	90	ONG, Capsule scissors	135
HEIMANN, vitreous body scissors	168	LANCASTER, Eye specula	5	OSHER, IOL Scissors	138
HELVESTON		Lens loops	56	OSHER-NEUMANN, Marking instruments	66
Hook	23	LESTER			
Retractor	45	IOL-Manipulator	28	<b>P</b>	
HENRY, Cilia forceps	91	Iris forceps	74	PARK-GUYTON, Retractors	9
HERBA, Chalazion curette	54	LESTER-BURCH, Retractors	6	PATON, Scarifier	37
HESS, Iris forceps	74	LEWIS, Loop	56	PAUFIQUE, Suture forceps	94
HIRSCHMANN, Lens spatula	26	LIEBERMANN		PFAEFFL, Femto flap lifter	25
HOFFER, Marking instrument	66	Micro Finger	32	Phaco keratome	39
HOFFMANN		Retractors	1	Phaco spatula	49
Nucleus dividing hook and lens spatula	29	LISTER, Enucleation scissors	168	PISACANO, Lens nucleus rotator	33
HOLTH, Punch	62	LIVERNOIS		PLANGE	
HUNT, Chalazion forceps	90	Lens holding forceps	78	Foreign body instrument	52
Hydro Chopper	40	Lens holding and folding forceps	79	Foreign body spud	51
		LORDAN, Chalazion forceps	90	POLACK, Corneal suturing forceps	82
<b>I</b>		LUND, Iris hooks	31	PRINCE, Advancement forceps	86
Implantation forceps	81	LUNTZ-DODICK, Punch	62	Punches	62 ff
I. O. L.-Instruments	24				
INAMURA, Capsulorhexis-forceps	75 ff	<b>M</b>		<b>R</b>	
Infusion handles	122	MACKENSEN, Keratoplasty scissors	145	R. KOCH, Irrigation handle	40
Iris forceps	68 ff	MALTZMAN-FENZL, Lens manipulator	34	RAININ, Cannulas	115
Iris knives	42	Marking instruments	65	Razor Blade holder	113
Iris scissors	129 ff	MASKET, Capsulorhexis-forceps	75, 77	RANDOLPH, Cannulas	117
		MAUMENEE-PARK, Retractors	9	REMKY	
<b>J</b>		Mc GUIRE		Forceps	70
JACOBI, Reposition hook	32	Eye scissors	156	Superior rectus forceps	84
JAECKER, Knife for suture removal	41	Spring handle scissors for Micro-Surgery	138	RENTSCH, Lens manipulator	34
JAEGER		McCULLOUGH, Strabismus forceps	85	ROLLET	
Keratome	39	McDONALD, IOL-forceps	79	Bone cicel	43
Lid plate	18	McINTYRE, Retractors	15	Hook for lacrimal sack	20
Strabismus hook	21	McPHERSON		ROSEN	
JAFFE		Tying forceps	95	Irrigation handle	40
Lens spatula	26	IOL-forceps	80	Nucleus splitter	31
Lid retractors	18	Forceps for Micro-Surgery	71	RUEDEMANN, Dilators	59
JAFFE-KNOLLE, Iris hook	26	MELLINGER, Retractors	4		
JAMESON,		MELLINGER-BEARD, Retractors	4	<b>S</b>	
Advancement forceps	87	MELLINGER-GIMBLE, Retractors	4	SATO, Corneal knife	38
Strabismus hook	22	MEYER, Foreign body gouge	50	Sato knives	38
JESS, Fixation forceps	83	MEYER-SCHWICKERATH, Localizer	65	SATTLER, Advancement forceps	86
JOHN HOPKINS, Serrefine	60	MEYHÖFER, Chalazion curette	54	SAUPE, Cilia forceps	92
JONES, Towel clamp	60	MODELL FRANKFURT, Iris spatula	46	SAUTTER, Cannulas	115
		MODELL GIESSEN		Scalpel handles	114
<b>K</b>		Lacrimal probe	59	Scleral depressor	44
KAGAWA, Nucleus dividing hook	25	Spatula and retractor	46	SCHEPENS	
KALT, Needleholders	100	MODELL HEIDELBERG		Orbital retractor	17
KANSAS, Fragment forceps	79	Elevator	42	Skleral Depressor	44
KATZIN, Corneal scissors	140	Raspatory	42	SCHIOETZ, Tonometer	112
KELLY, Punch	62	MODELL TUEBINGEN		SCHOCKET, Scleral depressor	44
KELMAN, Micro-forceps	81	Tying forceps	93 f	SCHOTT, Retractors	12
KELMAN-McPHERSON, Micro-forceps	81	Vannas-type scissors	133	SCHWEIZER MODELL	
Keratomes	39	MOORFIELD, Suture forceps	95	Cilia forceps	91
Keratoplasty spatula	46	MUELLER, Lacrimal sac retractor	16	Corneal trephines	64
KERSHNER, Retractors	3	MULDOON, Dilators	59	Foreign body needle	50
KIMURA, Platinum spatula	45			SHAAF, Foreign body forceps	92
KIRBY, Lens expressor hook	53	<b>N</b>		SHEETS, Cannulas	117
KNAPP, Irlmessenger	42	NAGAHARA		SHEPARD	
KNOLLE, Iris hook	26	Nucleus Chopper	34	Cannulas	117
KOCH		Lens spatula	33	Soft IOL inserting forceps	80
Iris spatula	49	Irrigation handle	40	SINSKEY, Lens hook	24, 27
Manipulator	26	NEUHANN		Silicone-mats	124
Nucleus splitter	31	Fixation ring	67		
Spring handle scissors for Micro-Surgery	136	Iris hooks, nucleus dividing hook	29		
KRATZ-BARRAQUER, Eye specula	14				

	Page
<b>SNELLEN</b>	
Entropium forceps	89
Lens loop	56
SPALECK, Soft IOL inserting forceps	78
Spatulas	45 f
<b>SPEEMANN</b>	
Jeweler type foreign body forceps	92
SPENCER, Stitch scissors	157
Spoons	53
ST. MARTIN, Suture forceps	95
STEINMETZ, Spatula	25
<b>STEVENS</b>	
Cannulas	117
Tenotomy scissors	148 f
Lens hook	22
STEVENSON, Lacrimal sac retractor	16
Stitch scissors	157
Strabismus forceps	85
Strabismus scissors	150 f
Suture forceps	93 ff
<b>T</b>	
TEARSE, Meibomian expressor forceps	89
<b>TENNANT</b>	
Lid retractors	18
Tying forceps	69, 95
Tenotomy scissors	147 ff
THORLAKSON, Eye specula	3
<b>THORNTON</b>	
Marking instrument	66
Fixation ring	67
Tissue forceps	68
TOOKE, Corneal knife	36
Trays	123
Trephines	64
<b>TROUTMAN</b>	
Cannulas	116
Corneal scissors	139
Lens loop	56
Lens spatula	46
Micro-Iris spatula	48
Needleholders	108
Razor Blade holder	113
Superior rectus forceps	84
TYRELL, Iris hooks	19
<b>U</b>	
URIBE-STERN, Capsule scissors	135
UTRATA, Capsulorhexis-forceps	75 ff
<b>V</b>	
<b>VANNAS</b>	
Capsule scissors	135
Scissors	131 ff
Vannas-type scissors	133 f
Vannas-type scissors	133 f
Vitreoretinal scissors	159 ff
Vitreoretinal forceps	159 ff
<b>W</b>	
WATZKE, Sleeve spreading forceps	88
WEBER, Lens loop	55
<b>WECKER</b>	
Iris scissors	130
Iris spatula	47
WEISS, Retractors	4, 6
WELLS, Enucleation spoon	55
<b>WEST</b>	
Bone cicell	43
Bone gouge	43
WESTCOTT, Tenotomy scissors	147 f

	Page
<b>WESTCOTT (Mc PHERSON)</b>	
Spring handle scissors for Micro-Surgery	139
<b>WHEELER</b>	
Dicission needle	41
Double ended spatula	52
<b>WILDER (NETTLESHIP)</b>	
Lacrimal dilator	59
<b>WILLIAMS, Retractors</b>	14
<b>WILMER, Eye scissors</b>	155
<b>WORST, Pigtail probe</b>	58
<b>WORTH, Advancement forceps</b>	87
<b>Z</b>	
<b>ZIEGLER, Iris knife</b>	42
<b>ZUERCHER MODELL, Suture forceps</b>	97

We reserve the right to change the prices and technical details, for printing mistakes or for other incidental mistakes we take no responsibility.

Wir behalten uns das Recht vor, die Preise und die technischen Angaben zu modifizieren. Für die Druckfehler und sonstigen Irrtümer wird keine Verantwortung übernommen.



## Impressum

Autorisierter Distributor

salensa | Gabriele Sadlowski e.K.  
Sandgraben 4 · 88142 Wasserburg (D)

T +49 8382 94 30 225 · [vertrieb@salensa.de](mailto:vertrieb@salensa.de)  
Amtsgericht Kempten · HRA 9986

Sämtliche in diesem Katalog aufgeführten Produkte werden hergestellt von:  
Carl Teufel GmbH & Co. KG, Tuttlinger Straße 30, 78576 Emmingen-Liptingen-Deutschland.  
Der Hersteller ist Inverkehrbringer und verantwortlich für die Konformität gemäß Verordnung (EU) 2017/745 (MDR).

Dieser Katalog richtet sich ausschließlich an medizinische Fachkreise im Sinne des Heilmittelwerbegesetzes (HWG).

Stand: 03/2026 · Alle Angaben ohne Gewähr. Änderungen und Irrtümer vorbehalten.

---

